

SD 170 24V DC

90-180 kW



SD 170 24V DC Oil Burner features:

- Packaged compact oil burner complete with burner programmer and oil pump
- Single stage control
- 24V DC controls for mobile applications (road maintenance, military, remote locations etc.)
- Quiet in operation and designed for easy maintenance
- Designed and approved in accordance with the European Standard EN 267
- Industry standard components easily available
- All kW ratings based on NCV
- Optional extras
 - IP65 motor
 - Continuously Running Fan (CRF)
 - Flame tube length
 - Air inlet filter
 - Junction box for remote control box location
 - Pressure gauge manifold
 - Pre-heater



For more information on all Nu-way products please visit www.nu-way.co.uk

Burner Type	SD 170 24V DC
Capacity	90 – 180 kW
Motor	100W
Control unit	Honeywell DKO 992
Fuel pump	Danfoss BFP11
Operation mode	Single Stage

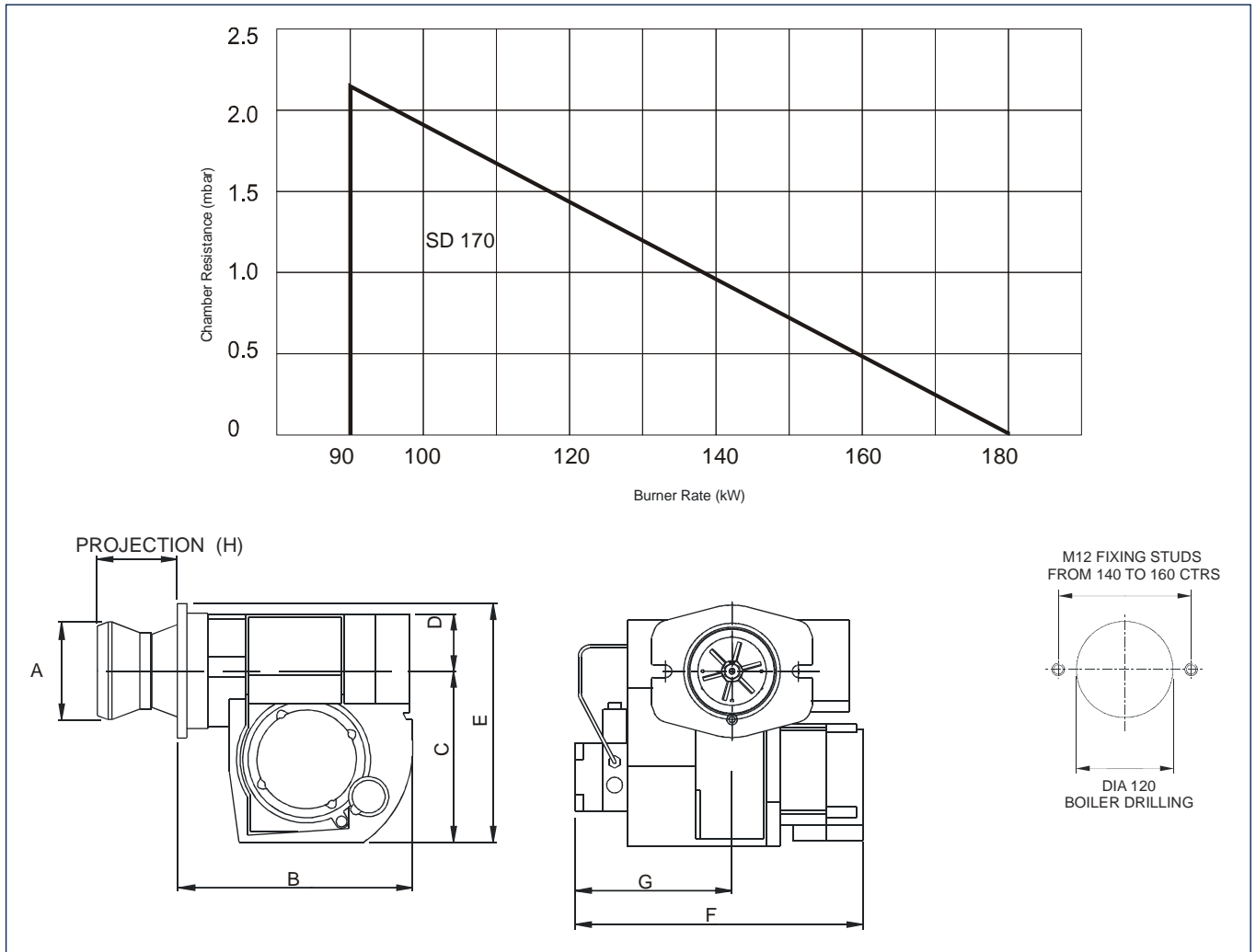

Burner	A	B	C	D	E	F	G	H
SD 170 24V	102	268	200	54	262	295	158	Projection to suit customers requirements, typically up to 190 mm

Design subject to change.

Enertech Limited, Ten Acres, Berry Hill Industrial Estate, Droitwich Spa, Worcestershire, WR9 9AQ

tel: +44 (0) 1905 794331 • fax: +44 (0) 1905 794017
 email: info@nu-way.co.uk • web: www.nu-way.co.uk



23-10-2018