

PG660 Series Gas Burner



PG660 Gas Burner features:

- Available configured for Natural Gas, LPG or Biogas - other gases on request
- Applications include steam and high pressure hot water boilers, as well as more diverse processes such as rotary dryers
- Separate floor-mounted combustion air fan unit
- Fully modulating operation as standard
- Microprocessor based Autoflame burner management (Siemens LMV5 or ETC options) with servo motor fuel/air ratio management for up to 7:1 turndown
- Integrated PID control for accurate response to demand
- Optional Extras:
 - Exhaust gas analysis for passive monitoring of emissions
 - Oxygen trim for improved emissions control
 - Variable speed drive combustion fan for improved electrical efficiency
 - Air inlet silencer (<85 dBA)
 - Non Autoflame mechanical linkage
 - Separate or integrated water level controls for steam boiler
 - Data Transfer interface
 - Low NOx head design (< 80 mg/kWh)*
- Optional air and gas handing configurations available to suit appliance
- All kW ratings are net CV



ISO9001

For more information on all Nu-way products
please visit www.nu-way.co.uk



Enertech Group

Model PG		660/17.2	660/17.6	660/18.0	660/18.3	660/18.7	660/19.0	660/19.4	660/20.0
Max Output / Res (nett CV)	MW	15.5	15.9	16.2	16.5	16.9	17.1	17.5	18.0
Fan Size	kW	45	45	45	45	45	45	45	45
Electrical Supply	V/Hz	400/50	400/50	400/50	400/50	400/50	400/50	400/50	400/50
Gas train inlet		PIN16 DN150	PIN16 DN150	PIN16 DN150	PIN16 DN150	PIN16 DN150	PIN16 DN150	PIN16 DN150	PIN16 DN150
Gas train size		6"	6"	6"	6"	6"	6"	6"	6"
Gas inlet pressure (min/max)	mbar	140/300	140/300	140/300	140/300	140/300	140/300	140/300	140/300
Operation		Fully Modulating	Fully Modulating	Fully Modulating	Fully Modulating	Fully Modulating	Fully Modulating	Fully Modulating	Fully Modulating
Control Unit		Autoflame Mini Mk7	Autoflame Mini Mk7	Autoflame Mini Mk7	Autoflame Mini Mk7	Autoflame Mini Mk7	Autoflame Mini Mk7	Autoflame Mini Mk7	Autoflame Mini Mk7
Turndown		up to 7:1	up to 7:1	up to 7:1	up to 7:1	up to 7:1	up to 7:1	up to 7:1	up to 7:1
Flame Monitor		UV Sensor	UV Sensor	UV Sensor	UV Sensor	UV Sensor	UV Sensor	UV Sensor	UV Sensor
Flame tube lengths	mm	430/610	430/610	430/610	430/610	430/610	430/610	430/610	430/610
Noise	dBA	93 <85 with silencer	93 <85 with silencer	93 <85 with silencer	93 <85 with silencer	93 <85 with silencer	93 <85 with silencer	93 <85 with silencer	93 <85 with silencer
NOx	mg/kWh	140-190*	140-190*	140-190*	140-190*	140-190*	140-190*	140-190*	140-190*
CO	mg/kWh	<100	<100	<100	<100	<100	<100	<100	<100

Information for standard design and subject to change.

* Low NOx head design <80mg/kWh subject to suitable combustion chamber design.

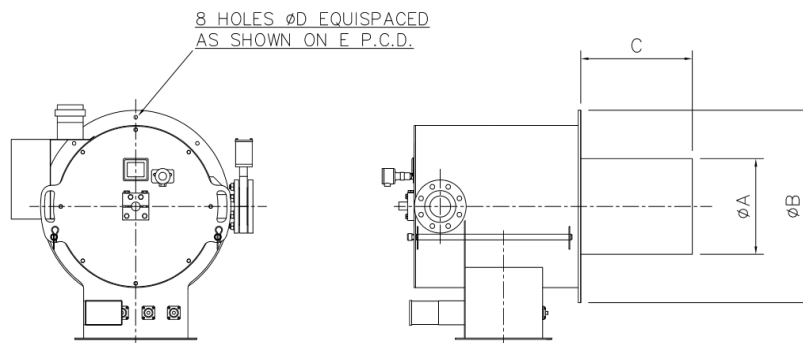
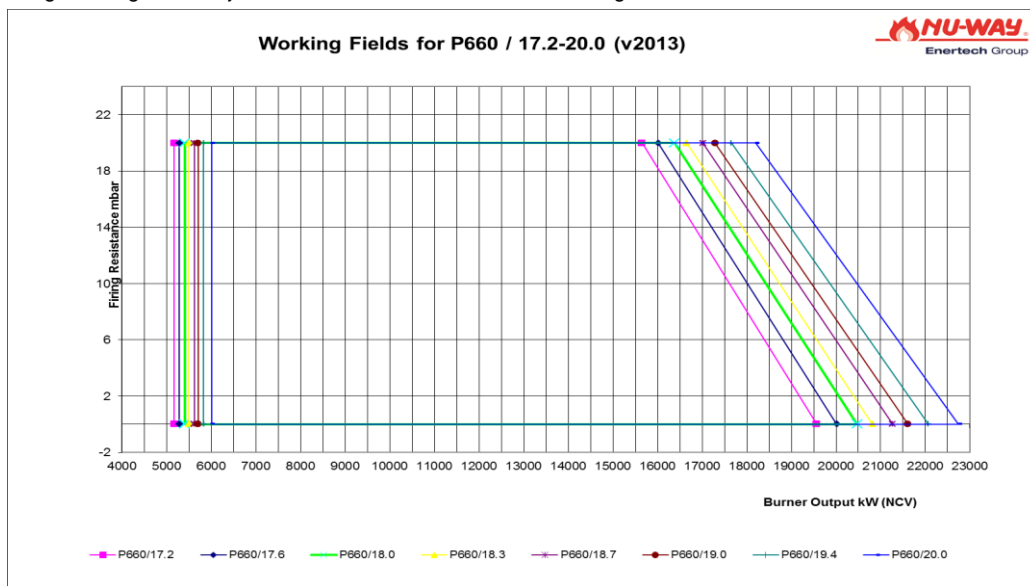

Dimension	A	B	C	D	E
mm					

Enertech Limited, Ten Acres, Berry Hill Industrial Estate,
Droitwich Spa, Worcestershire, WR9 9AQ

tel: +44 (0) 1905 794331 • fax: +44 (0) 1905 794017
email: info@nu-way.co.uk • web: www.nu-way.co.uk



Enertech Group

23-10-2018