

MOL 540 Oil Burner



MOL 540 Oil Burner features:

- Energy saving and compatible with environmental requirements
- Quiet in operation and designed for easy maintenance
- Reliable and trouble-free
- Designed and approved in accordance with the European Standard EN 267
- Suitable for high resistance boilers
- Industry standard components easily available
- Designed for high/low operation
- Plug-in contact facilitates the installation
- With hydraulic ram air adjustment
- Fuel – Light distillate oil Class D (1.5-5.5 cSt @ 40°C)
- All kW ratings are nett CV



For more information on all Nu-way products
please visit www.nu-way.co.uk

Type		MOL 540
Capacity	kW	101-540
Motor	V/Hz	230/50
	W / A (Fuse)	450 / 10
Start / Run Current	Amps	12.0 / 3.3
Control box		Siemens LMO24
Fuel pump		Suntec A2L75C
2-Stage		•
Gross weight	kg	34
Volume	m ³	0.22

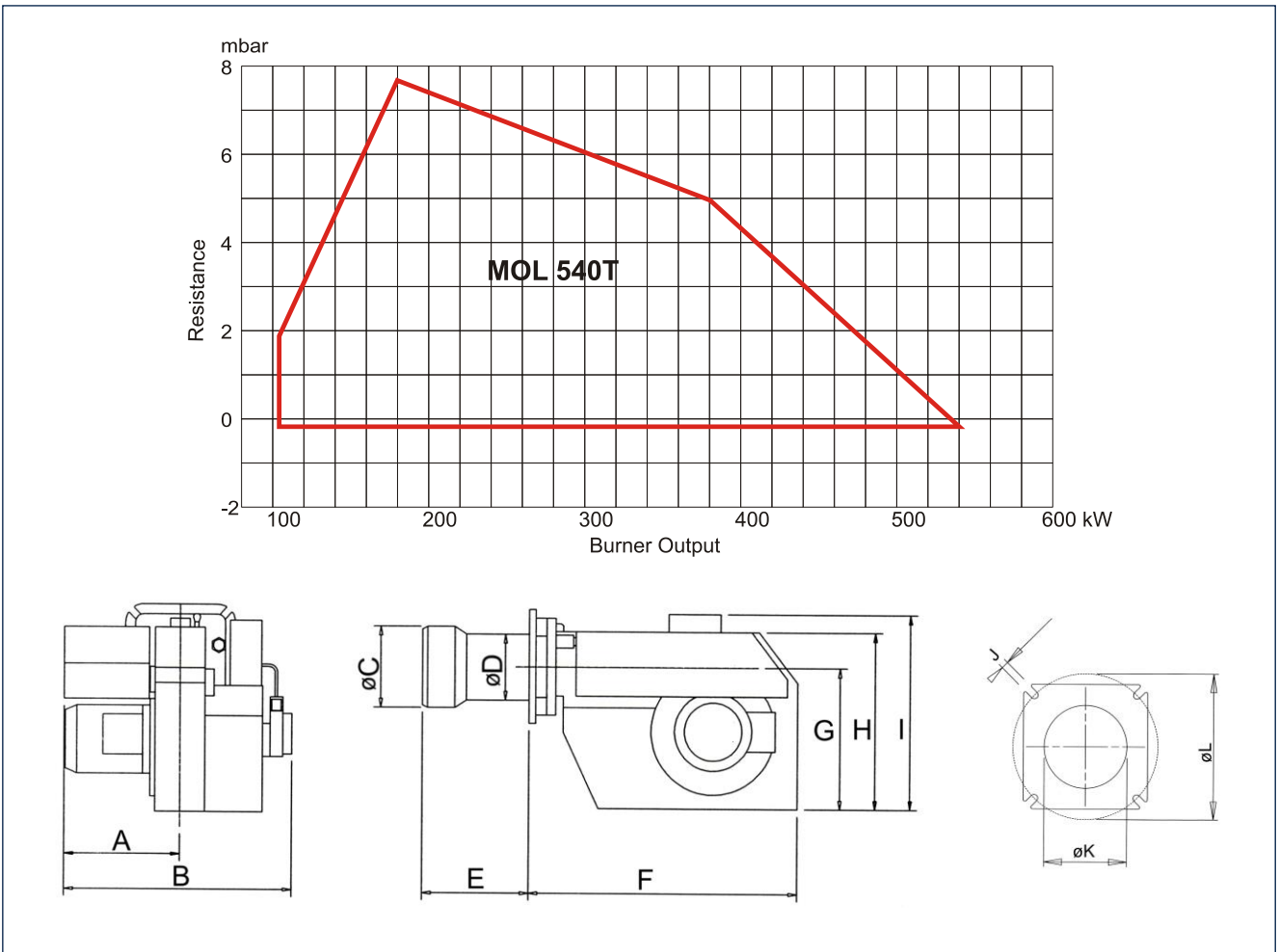

Burner	A	B	øC	øD	E*	F	G	H	I	J	øK	L
MOL 540T	262	515	162	134	240	480	252	328	335	14	140	200-260

* Extended lengths Available

Enertech Limited, Ten Acres, Berry Hill Industrial Estate, Droitwich Spa, Worcestershire, WR9 9AQ

tel: +44 (0) 1905 794331 • fax: +44 (0) 1905 794017
 email: info@nu-way.co.uk • web: www.nu-way.co.uk



Enertech Group

23-10-2018