

MGN 1550 / 2000 LN Gas Burner

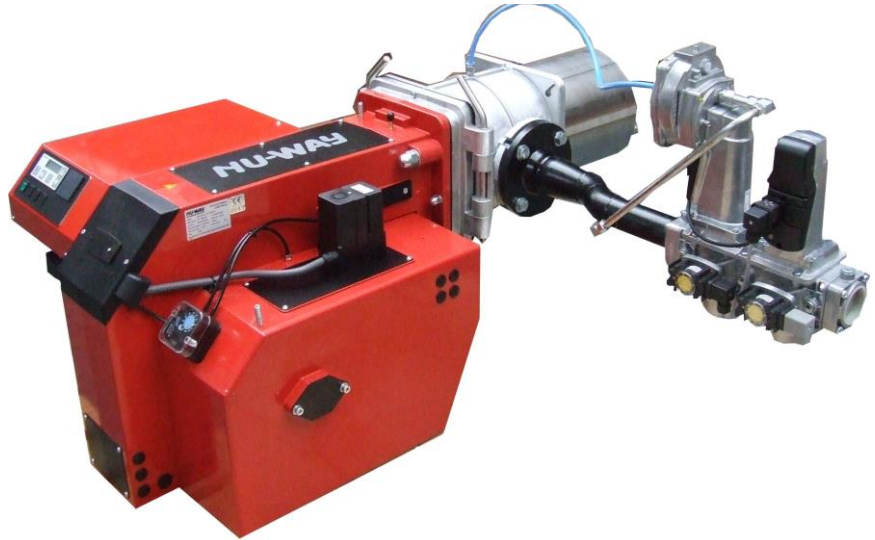

MGN 1550/2000 LN Gas Burner features:

- Energy saving and compatible with environmental requirements
- Quiet in operation and designed for easy maintenance
- Designed and approved in accordance with the European Standard EN 676
- Plug-in contact facilitates the installation
- Right-hand gas train as standard (left-hand optional extra)
- Hinged flange for ease of servicing
- Designed for two stage operation (Modulation controller, sensor and pocket optional extra)
- Available for natural gas
- Low NOx as standard
- Range of gas trains to suit gas supply pressure
- All kW ratings are nett CV



For more information on all Nu-way products
please visit www.nu-way.co.uk

Type		MGN 1550	MGN 2000
Capacity	kW	420-1550	700-2000
Motor	V/Hz	400 / 50	400 / 50
	kW/A (Fuse) + Control fuse	4.0 / 3 x 20 + 1 x 10	4.5 / 3 x 20 + 1 x 10
Start/Run Current	Amps	14.5 / 10.2	16.5 / 11.4
Control box		MPA 22	MPA 22
Flame monitoring		UV	UV
Operation mode		2-stage / Modulating	
Gross weight - burner	kg	115	120
Gross weight - standard gas train	kg	21	21
Noise emission	dBA	≤ 78	≤ 78
NOx emission	mg/kWh	< 80	< 80

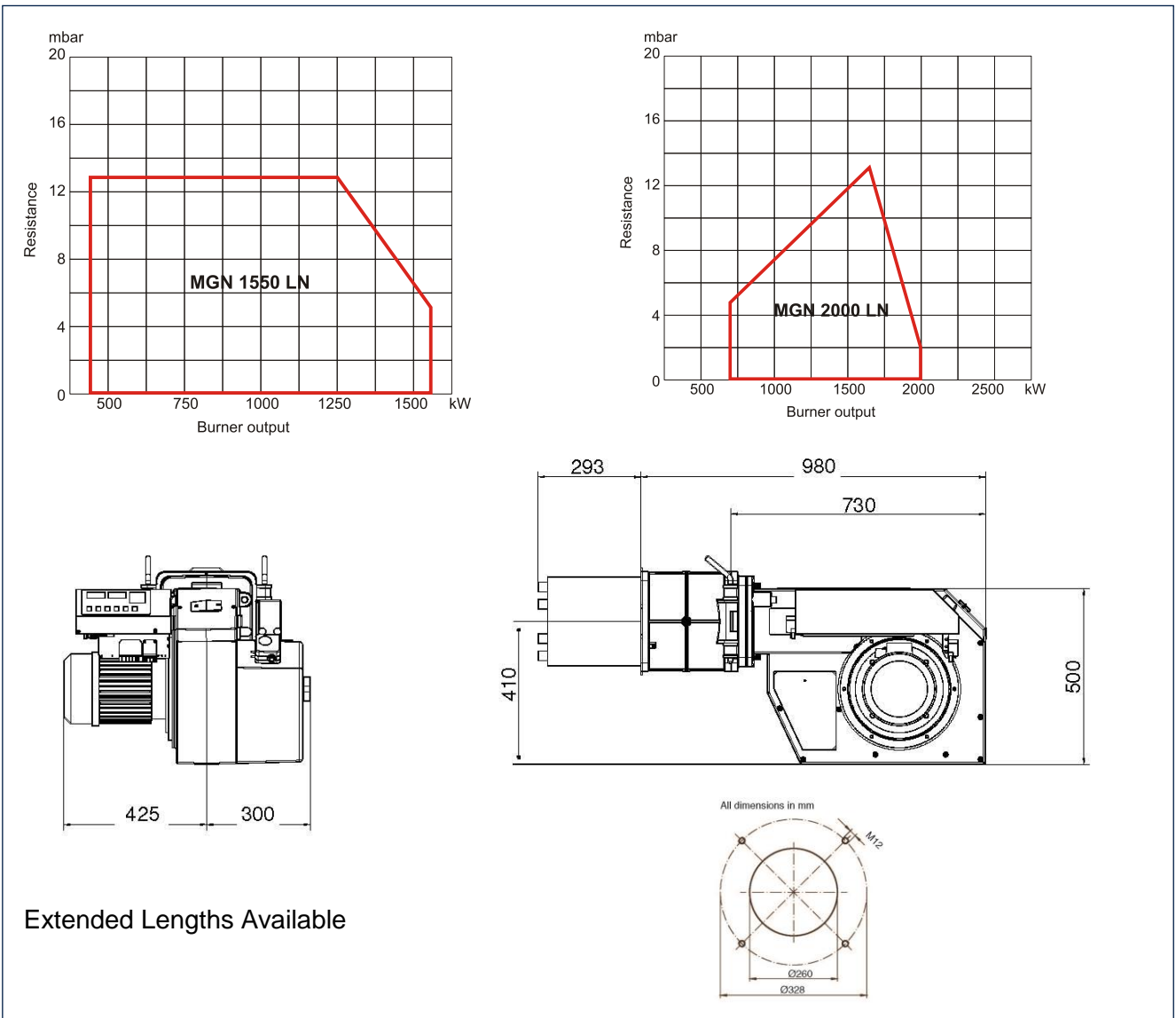

Enertech Limited, Ten Acres, Berry Hill Industrial Estate,
Droitwich Spa, Worcestershire, WR9 9AQ

tel: +44 (0) 1905 794331 • fax: +44 (0) 1905 794017
email: info@nu-way.co.uk • web: www.nu-way.co.uk



Enertech Group

23-10-2018