



BY APPOINTMENT TO
HER MAJESTY THE QUEEN
MANUFACTURERS OF
COMBUSTION EQUIPMENT
NU-WAY HEATING PLANTS LTD.
DROITWICH

INSTALLATION & SERVICE MANUAL

FOR

MODEL ZL FULLY AUTOMATIC LIGHT OIL BURNERS

ON-OFF LOW-FLAME START HIGH-LOW-OFF

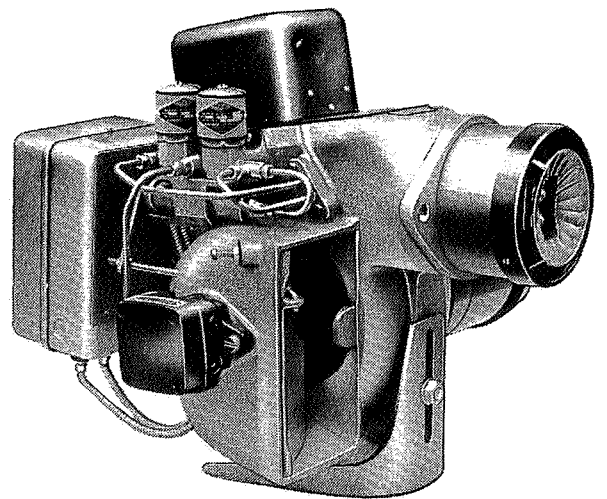
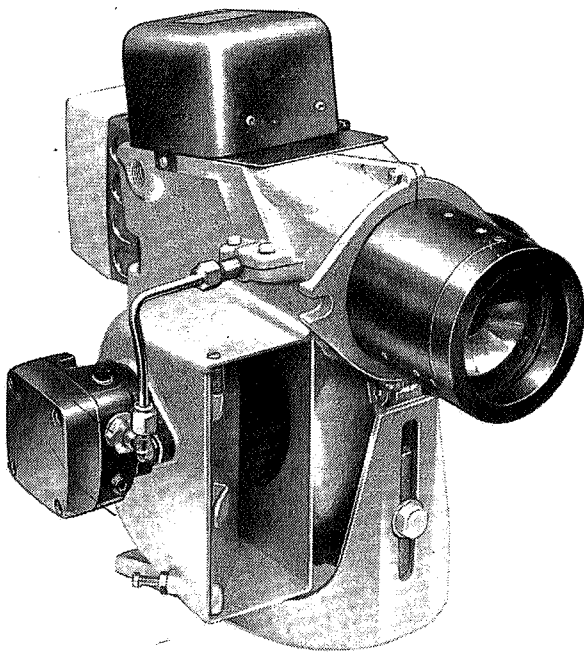

NU-WAY HEATING PLANTS LTD.

**DROITWICH
WORCS**

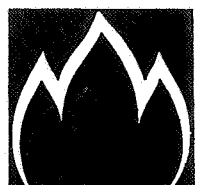

NU-WAY

IMPORTANT

READ THESE INSTRUCTIONS RIGHT THROUGH BEFORE STARTING TO INSTALL THE BURNER.

WHEN THE BURNER BEING INSTALLED IS A COMPONENT OF A PROPRIETARY OIL-FIRED BOILER OR AIR HEATER, THE INSTRUCTIONS SUPPLIED WITH THE MAIN HEATING UNIT ARE TO BE STRICTLY FOLLOWED. ANY SUCH INSTRUCTIONS HAVE BEEN EVOLVED AFTER LABORATORY AND FIELD TRIALS OF THIS PARTICULAR COMBINATION OF BURNER AND HEATING UNIT AND THEY THEREFORE TAKE PRECEDENCE OVER THE GENERAL INSTRUCTIONS CONTAINED IN THIS BULLETIN.

INDEX

INSTALLATION INSTRUCTIONS	Page
Introduction	1
Oil Supply System and Storage Tank	1
Electrical Wiring	1
Combustion Chamber	2
Front Plate	2
Damper	2
Hints for Silent Operation	2
Testing the Installation	2
Instructing User	2
Maintenance Instructions	3
Fuel Pump	3
Nozzle and Electrodes	3
Motor	3
Oil Filter	3
Oil Tank	3
Controls	3
Fan Runner	3
Fault Finding—General	4
Firing and Fault Finding ZL11 and ZL2D High/Low	5
Fault Finding—High/Low Models	6
Initial Fault Finding Models ZL11 L.F.S. (Low Flame Start)	7
Combustion Chamber Details	8
Leading Dimensions	9
Burner Electrical Loadings	9
Burner Outputs	10-11
Standard Air Handling Parts	12
Sundstrand Fuel Pump	13-14
Danfoss Fuel Pump	15-16
Landis-Gyr Control Box LAB 1

Nu-way Policy is one of continuous improvement. The right to change prices and specifications without notice is reserved.
The company supplies goods and does work only on its Standard Conditions of Business, copies of which are available free upon request.

OIL BURNER INSTALLATION AND OPERATING INSTRUCTIONS.

MODELS ZL.2, ZL.2D, ZL.11.

INSTALLATION INSTRUCTIONS.

INTRODUCTION.

Where the unit is being applied to an existing heating system, arrange for the flue passages and heat transfer surfaces to be cleaned and for the chimney to be thoroughly swept.

Check boiler doors for fit and seal any cracks and other unwanted openings in the boiler, flue system and chimney brickwork.

The top of the chimney should be above all roofs within a radius of 30 feet.

If a cowl is fitted it should be removed.

See that the flue pipe from the boiler or heater finishes flush with the inside wall of the chimney and does not protrude beyond this point.

No solid fuel-fired boiler or heater must be allowed to discharge into the same flue as the oil-fired unit.

OIL SUPPLY SYSTEM & STORAGE TANK.

Use single-pipe gravity feed oil supply system whenever possible.

Use single-pipe system on all installations where bottom of storage tank is not less than 6 inches above the oil inlet on the burner fuel pump. When using gravity feed the internal by-pass within the pump must be open (see instructions packed with the burner pump).

When the pump inlet is higher than the bottom of the fuel tank a two-pipe "suction-lift" oil supply system must be used. (See instructions with burner pump.)

When using a two-pipe suction lift supply system, the internal by-pass port in the pump must be closed. Use the plug provided for this purpose supplied in the bag attached to the fuel pump. (See instructions packed with the fuel pump for fitting).

Keep oil pipes out of the way but run them by the most direct path.

Copper tube is easier to work than steel pipe. Iron fittings and steel pipes should be hammered before installation to remove loose scale.

Galvanised Pipe and Fittings must not be used.

DO NOT join copper tubes with soldered joints or capillary fittings.

For screwed pipe connections use mastic-type jointing compound or plastic tape, not hard-setting paste. When oil is fed to the burner by gravity use $\frac{3}{8}$ " pipe (or larger). $\frac{1}{2}$ " pipe should be used on suction-lift systems when the burner is not more than 20 feet from the tank. Incline all pipe runs slightly to avoid air traps. Fit a tee-piece and plug at any point where air trapping is likely, i.e. at highest point in any run.

Best tank position is outside the building. If not possible and the tank must be mounted indoors, check local fire regulations, if any. Place indoor tank in separate fire-resisting chamber or, if this not possible, within brick catch-pit having capacity at least 10% greater than tank capacity.

Do not mount tank on a roof except as very last resort.

Mount tank with $\frac{1}{4}$ " - $\frac{1}{2}$ " fall per foot of length away from oil outlet and towards sludge cock.

Fit fill and vent lines of same size in accordance with oil suppliers recommendations.

Fit fusible-link type fire-valve as near tank outlet as possible. Fit extra fusible links near the tank (if indoors) and in any closed passage through which oil pipes run.

ELECTRICAL WIRING.

For wiring details see diagram supplied with heater unit or enclosed herewith.

Wiring diagrams showing electrical connections for all Nu-way burner/control combinations available upon request from Electrical Department, Nu-way Heating Plants Limited.

Wire in P.V.C. cable except near hot surfaces. For runs in these areas use asbestos-covered cable.

Leads to photo-cells must be screened or run in separate conduit.

Use flexible conduit for final connections to burner, thermostats and flue thermostat (if used).

Ensure good bonding by running separate earth wire or strip along each flexible conduit to the fitting at either end.

Flexible conduit to flue thermostat must be long enough to permit easy withdrawal of the instrument for cleaning.

COMBUSTION CHAMBER.

Where the oil burner is part of an oil-fired boiler or air heater unit fit combustion chamber as directed by manufacturers of the unit.

Where no special instructions are provided construct combustion chamber generally in accordance with the following recommendations :-

For burner fitted with simple swirler/air cone—build fire—box to drawing No.E4097/1 (ZL2 & ZL2D) or XS.8073 (ZL7 & ZL11).

For burner fitted with Flame Funnel — construct fire—box to drawing No.DD.1024.

For burner fitted with latest Diffuser air system — build fire—box to drawing No.DD.1143 (ZL2, ZL2D and ZL11 only).

Detailed drawings of combustion chambers for many Nu—way burner/boiler combinations are available upon request. State make of boiler, plinth height, boiler model number and proposed burner model number.

FRONT PLATE.

See special fire—box drawing or relevant burner "Leading Dimensions" drawing for front plate drilling details.

DAMPER.

Lock the flue damper fully open on single — boiler jobs. If occasional closing of damper necessary, as on multi-boiler or heater installations, arrange flue damper so that closing is impossible without removal of some locking device (e.g. padlock).

If draught exceeds 0.08" w.g. over the fire a draught stabiliser should be fitted in position recommended by the makers. Draught over the fire when the burner is running should be between 0.02" — 0.05" w.g.

HINTS FOR SILENT OPERATION.

Final connection of fuel supply to burner unit should be through a flexible oil pipe.

Insulate pipes in clips, through walls, from building joists and from each other.

Burner draught tube should not touch boiler frontplate.

Fill gap between frontplate and tube with asbestos string

When burner foot—mounted, fit cork pad beneath burner pedestal and underneath head of each holding—down bolt. (Fit good electrical earth strip when holding bolts insulated in this way).

TESTING THE INSTALLATION.

Bleed oil line free of air up to burner. Bleed pump free of air by slackening off plug in pressure gauge port and briefly running burner motor. (See makers instructions). Remove burner inner assembly and check that electrodes are set in the correct position (see diagram). Replace inner assembly.

If flue thermostat fitted, set to start position (see instructions enclosed with control) and close main wall switch. The burner should start and be left running for approximately 30 minutes to dry out the fire—box.

Check all pipework and connections for oil leaks.

Test electrical control circuits (see test list in instruction sheet packed with control). Fit oil pressure gauge (scale 0—200 p.s.i.) into pump pressure gauge port and check that oil atomising pressure is correct.

Correct Atomising Pressures.

All ZL with Swirler/Air Cone — 100 p.s.i.

All ZL with Flame Funnel — 140 p.s.i.

ZL2 with Diffuser — 125 p.s.i.

ZL2D & ZL11 with Diffuser — 140 p.s.i.

If adjustments required follow instructions enclosed with fuel pump.

When heating plant is warm check combustion efficiency with CO₂ sampling instrument, if available. Adjust burner air supply to give acceptable reading (suggested minimum — 10% CO₂).

If CO₂ indicator not available adjust air setting to give slight haze at the top of the chimney.

INSTRUCTING USER.

Show completed installation to user and demonstrate starting and stopping of burner, both normal stop and "emergency stop".

Also demonstrate re-setting of combustion control and indicate correct thermostat settings.

Demonstrate procedure for de-sludging fuel tank before each fuel delivery.

Urge user to conclude service agreement with the installer.

MAINTENANCE INSTRUCTIONS

BEFORE DOING ANY WORK ON THE BURNER TAKE CARE TO SEE THAT THE MAIN ISOLATING SWITCH IS IN THE "OFF" POSITION.

FUEL PUMP.

For maintenance and service instructions see the leaflet sent with the burner.

NOZZLE AND ELECTRODES

Hinge open the base of the transformer after slackening the round-head retaining screw. Loosen hexagon nut from pipe to nozzle also screw retaining inner assembly. Withdraw the inner assembly from the burner.

Use nozzle spanner to unscrew nozzle from inner assembly. Unscrew inner core and clean the nozzle body, swirler and core separately. Take great care not to scratch the nozzle. Flush oil away with a solvent or under a running tap or with an air line. Scrape only when dirt is visible and then with cardboard or paper rather than with a wooden scraper.

Never use a Metal Scraper.

Re-assemble the nozzle taking care to see that all parts are kept very clean.

Take care to ensure that no dirt enters the oil pipes while the burner is dismantled.

Replace nozzle and check electrode setting (see diagram). Clean spark electrodes and insulators as necessary before re-checking electrode spark-gap setting.

Replace inner assembly and burner body. Before shutting transformer lid confirm that the bus-bars are contacting transformer terminal studs correctly.

Switch on burner and check for normal operation.

MOTOR.

Keep motor clean and dry. Any deposits of dust or dirt should be blown out occasionally. Surplus lubricant spreading from the bearing should be wiped away.

Lubricate burner motor as necessary. Burner motor is fitted with sleeve bearings which are primed with sufficient oil to last for six months operation. Replenish with best quality SAE20 oil (half a teaspoon-ful to each Bearing) every three months.

OIL FILTER.

If filter has disposable element renew element cartridge each year.

If filter has permanent element this should be washed in paraffin every six months. This operation may necessitate bleeding of the pump after re-assembly in order to remove air from the supply pipe.

Exceptionally dirty fuel may necessitate cleaning at more frequent intervals.

OIL TANK.

Check tank has been kept free from sludge by opening sludge cock and drawing off small quantity of oil.

Check that vent pipe is clear.

CONTROLS.

Clean flue thermostat or photo-cell viewing head as per makers instructions.

FAN RUNNER.

Keep fan blades clean and free from oil.

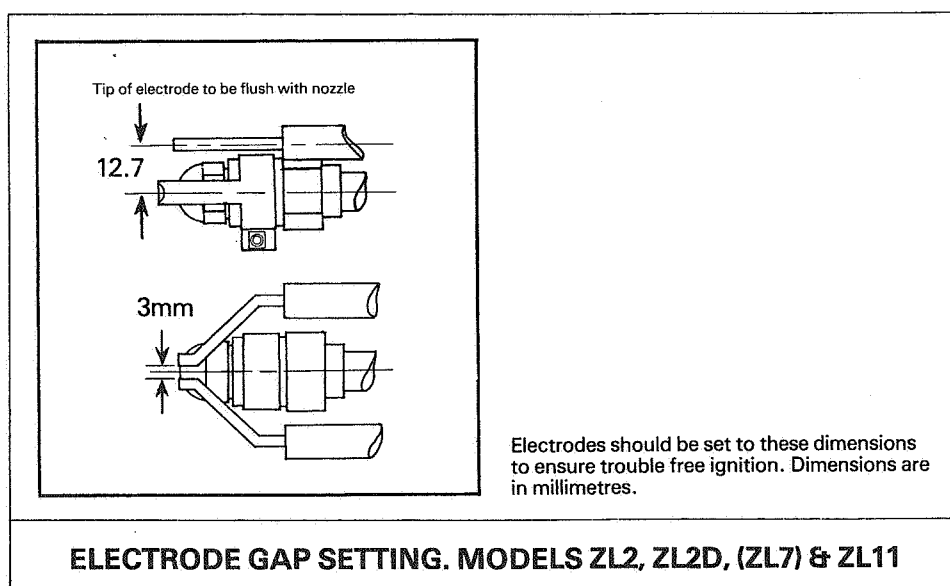

FAULT FINDING — GENERAL

Burner fails to start at all.

One of the instruments in the control circuit not making contact (i.e. not "calling for heat"). Check control or limit thermostat, pressure switch, time switch, low water cut-out or room thermostats.

Flue thermostat (where fitted) stuck in the "hot" position — re-set per makers instructions.

P.E.Cell (where fitted) incorrectly energised by daylight.

Red warning light showing in controller.

Burner starts up but fails to light and then locks out showing red warning.

No spark at points; check bronze bus-bars making contact with transformer terminals, setting up electrode points, electrode and transformer insulators for cracks or tracking. Clean.

Spark does not ignite oil; check electrode setting (see diagram). Partly blocked or damaged nozzle causing uneven spray. Low oil pressure causing coarse narrow spray. (See under low oil pressure)..

No oil in tank or fuel level below outlet pipe.

Oil supply line restricted. Check stop valves, filters, fire-valve, foot valve (if any), anti-syphon valve (if any). Blocked nozzle.

Motor/pump rubber coupling failed through overload. Loose driving dog. Faulty pump.

Air leaking into supply pipe (particularly on suction-lift), probably indicated by noisy pump. Check all joints at filters, valve glands, pump glands, pump cover and pipe joints. Gravity head insufficient for single-pipe system or if already on two-pipe system, suction lift too great or by-pass plug not fitted in pump.

(N.B. it is essential to have a return oil line back to the tank when internal by-pass plug fitted to pump).

Flue thermostat (if fitted), sluggish in operation. This may be due to dirty stem or large airleak into flue before flue thermostat position.

Instrument may be mounted too far from the boiler or may be faulty.

Photo-electric cell (if fitted) may be faulty and remaining on its "Dark" contact. This may be due to a faulty cell or amplifier valve or faulty wiring. Where the p.e. cell controller is wall-mounted the leads to the p.e. cell must be screened or wired in separate conduit. The p.e. cell may be dirty.

Small sparky flame.

Partly blocked nozzle (producing uneven flame).

Too much air.

Smoky flame:

High oil pressure.

Swirler loose in nozzle or whole nozzle loose in adaptor. (Producing large flame).

Worn nozzle (producing very large flame).

Insufficient air.

Inadequate draught. Check boiler flues and chimney, look for air leaks everywhere. If chimney pot fitted, remove it. Is chimney being subject to down-draughts.

Blow-back on lighting-Fumes in boilerhouse — Oil and soot on combustion head and in draught tube.

Delayed ignition. Check electrodes etc.

Restriction in flue and chimney.

Low oil pressure

Pressure regulating valve on pump required adjustment or is sticking. Free the p.r. valve and set to correct operating pressure.

High oil pressure

Pump p.r. valve incorrectly set or sticking. Free the valve and set to correct pressure.

Restriction in return line to tank (two-pipe systems).

Internal by-pass plug fitted in pump but no return line run to tank.

(Restriction or lack of return line can cause much damage to pump, motor or coupling).

Noisy burner.

Restriction in oil supply or air leaks into supply pipe-line causing pump noise. Suction-lift too great, causing pump noise.

Loose fan runner.

Worn or dry motor bearings.

INITIAL FIRING AND FAULT FINDING INSTRUCTIONS FOR MODELS ZL2D AND ZL11 BURNERS WITH HIGH/LOW/OFF CONTROL

INTRODUCTION

ZL High/Low (H/L) models differ from the simpler on/off models in the following respects:

There are two atomizing nozzles arranged vertically above each other, each controlled by a magnetic valve. The top nozzle only sprays on low flame whilst both nozzles spray on high flame. The air inlet damper is adjusted to suit the rate of firing by a hydraulic ram operated by oil pressure from the high flame magnetic valve against a return spring within the ram itself. The high flame magnetic valve is energised by the H/L appliance controlling instrument during normal running, but is always de-energised for 15 to 30 seconds (dependent on the control box fitted), at each burner start, thus giving a low flame light up. The low flame magnetic valve and the burner motor operate together and are controlled by the on/off appliance controlling instrument. A limit instrument is normally fitted to the appliance also.

While the burner is both at rest and on low flame the ram is retracted by its internal spring, and the low flame air adjustment is made at the point where the ram arm and the damper rod connect.

When the burner is on high flame the ram is extended, and the high flame stop located on the side of the air inlet casing near the pump, is used to adjust the high flame air.

INITIAL FIRING

FOLLOW THE INSTALLATION INSTRUCTIONS FOR MODEL ZL2, ZL2D and ZL11 ON-OFF BURNERS. Up to but not including "Testing the Installation" (page 2).

TESTING THE INSTALLATION

Bleed the oil line to the burner. Bleed the pump free of air by slackening off the plug in the pressure gauge port and briefly running the burner motor (see pump maker's instructions). Remove the burner inner assembly (see page 3) and check that the electrodes are set in the correct position (see diagram).

Set the appliance H/L controlling instrument to the required operating temperature (or pressure). Initially set the on/off control instrument to a temperature some 10°F above this. Set the limit instrument 10°F above the H/L setting.

Initially, set the air damper one third open by means of the low flame stop. Manually extend the ram and set the high flame stop so that the damper can open almost fully. Turn on the burner and allow it to start. It will light on low flame and, in 15 to 30 seconds (dependent upon the model of control box fitted) change to high flame. Adjust the high flame stop to give a clean flame without unnecessary excess air and then run the installation for fifteen minutes approximately (until it is at normal running temperature).

Whilst still on high flame, again re-adjust the high flame stop to give a CO₂ reading of 10% to 12% (or as specified by the appliance manufacturer) - (See notes). Reduce the setting of the H/L control instrument until the burner changes to low flame. Adjust the damper linkage until a CO₂ reading 8% to 10% (or as specified by the appliance manufacturer) is achieved. See notes.

Reset the H/L control instrument.

NOTES:

The higher the CO₂ reading, the higher the appliance efficiency. This always assumes that the flame is clean. A dirty flame will soot up heating surfaces, lead to low appliance efficiencies and frequent cleaning. The maximum CO₂ setting with clean combustion will depend upon the rate of firing, the type of appliance and the effectiveness of its sealing. If only a very low CO₂ reading is obtainable with a clean flame reduce the appliance draught by some means and re-check. If much higher readings are obtainable search for appliance air leaks and seal these. When a smoke pump is available the smoke number should not exceed number 2 and should normally be 0 to 1.

Run the burner under normal load and check that the appliance control and limit instrument settings are satisfactory for the plant.

The oil pressure used on all ZL2D and ZL11 high/low burners is (unless otherwise specified) 140 p.s.i.

FAULT FINDING

The fault finding section for ZL2, ZL2D and ZL11 on-off burners (page 4) apply generally to the H/L models. However, additional notes on fault finding for H/L burners are given on page 4.

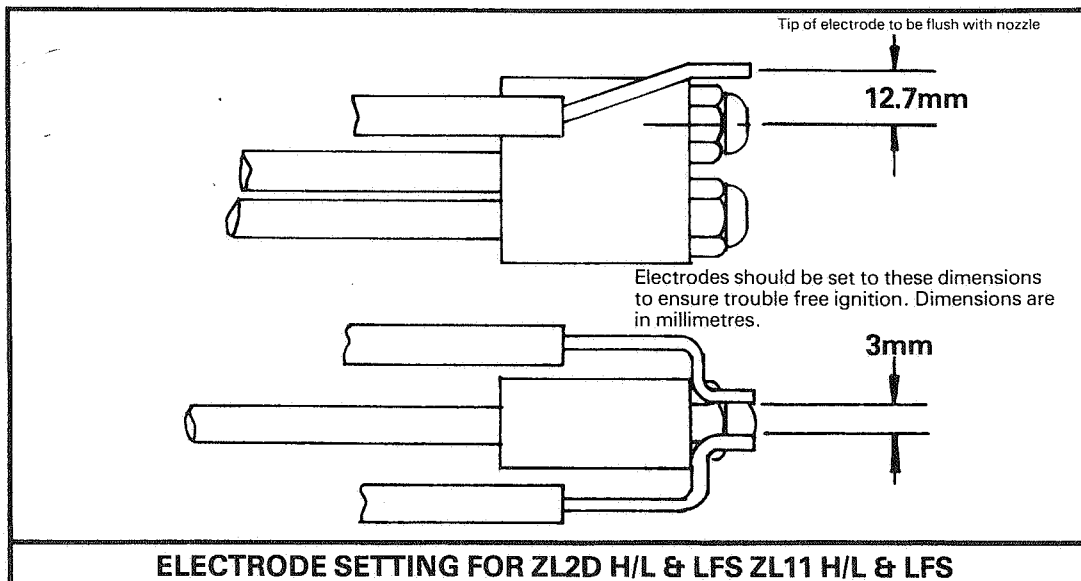

FAULT FINDING HIGH/LOW MODELS

BURNER WILL NOT CHANGE TO HIGH FLAME

Check the setting and operation of the H/L thermostat (or pressure switch).— H/L magnetic valve failing to open. (Faulty valve or no high flame signal from control box.)

FLAME FAILURE ON CHANGING TO HIGH FLAME (or small sparky high flame)

High flame nozzle blocked.

MOMENTARY FLAME FAILURE ON CHANGING TO HIGH FLAME

Restricted or insufficient oil supply to burner. (This causes a fall in oil pressure when increased flow is needed to supply ram and high flame nozzle.)

LARGE SMOKEY FLAME ON CHANGING TO HIGH FLAME

Air shutter sticking in the low flame position. Oil line to ram blocked (this specially applies if a restrictor is fitted in this line).

BURNER WILL NOT CHANGE TO LOW FLAME (except on initial start)

Check setting and operation of H/L control instrument.

BURNER STARTS ON HIGH FLAME

Faulty control or separate timer incorrectly set or faulty.

FAULT FINDING L.F.S. (LOW FLAME START)

BURNER WILL NOT CHANGE TO HIGH FLAME

Second stage magnetic valve failing to open (Faulty valve or no high flame signal from control box).

MOMENTARY FLAME FAILURE ON CHANGING TO HIGH FLAME

Restricted or insufficient oil supply to burner (this causes a fall in oil pressure when increased flow is needed to supply the high flame nozzle).

Burner Starts on High Flame Faulty Control.

INITIAL FAULT FINDING INSTRUCTIONS FOR MODELS ZL11 L.F.S. (LOW FLAME START OPERATIONS)

ZL11 L.F.S. burners differ from the more simple on/off models in the following respects: These burners incorporate two atomising nozzles which are arranged vertically one above the other, each nozzle being controlled by a separate solenoid valve. The method of operation is that the top nozzle sprays oil only on low flame while both nozzles spray oil on high flame.

The high flame solenoid valve is not energised until 15 to 30 seconds after the low flame valve, by means of a delay in the burner control, thus effecting a low flame start each time the burner starts up.

The low flame solenoid valve is wired to operate with the burner motor, the burner operation being controlled by the operating thermostat or pressure switch, a limit thermostat or pressure switch normally being provided for safety.

Air adjustment is controlled by a simple single air flap as fitted to the ZL11 On/Off burners.

INITIAL FIRING

Follow The Installation Instructions for Model ZL11 On/Off burners up to but not including "Testing the Installation" (Page 2).

TESTING THE INSTALLATION

Bleed the oil line to the burner. Bleed the pump free of air by slackening off the plug in the pressure gauge port and briefly running the burner motor (see pump makers instructions). Remove the burner inner assembly (see Page 3) and check that the electrodes are set in the correct position (see diagram).

The controlling instrument should be set to the required temperature (or pressure).

Set the limit instrument approximately 10°F above this setting or, in the case of pressure allow a reasonable margin between the two instruments.

Initially by means of the adjusting screw set the burner air flap two thirds open. Switch on the burner and allow it to start. The burner will light on low flame (top nozzle) and in 15 to 30 seconds, as described previously, it will change to high flame (both nozzles firing).

Adjust the burner air flap to give a clean burning flame without unnecessary excess air and then run the installation for approximately 15 minutes until it is at normal running temperature.

Whilst the burner is running on high flame, again adjust the air flap to give a CO₂ reading of 10% or 12% (or as specified by the appliance manufacturer).

NOTES :

The higher the CO₂ reading, the higher the appliance efficiency. This always assumes that the flame is clean. A dirty flame will soot up heating surfaces, lead to low appliance efficiencies and frequent cleaning. The maximum CO₂ setting with clean combustion will depend upon the rate of firing, the type of appliance and the effectiveness of its sealing. If only a very low CO₂ reading is obtainable with a clean flame reduce the appliance draught by some means and re-check. If much higher readings are obtainable search for appliance air leaks and seal these. When a smoke pump is available the smoke number should not exceed number 2 and should normally be 0 to 1.

Run the burner under normal load and check that the appliance control and limit instrument settings are satisfactory for the plant.

The oil pressure used on ZL11 L.F.S. burners is (unless otherwise specified) 140 p.s.i.

FAULT FINDING

The fault finding section for ZL11 On/Off burners (Page 4) applies generally to the low flame start models. However additional notes on fault finding for low flame start burners are given on page 6.

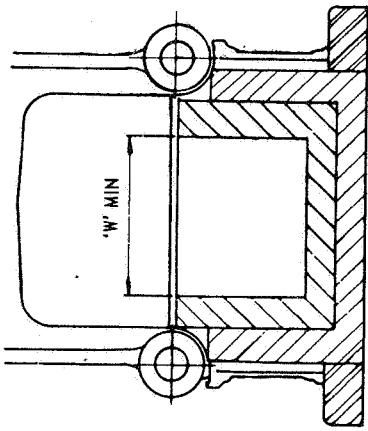
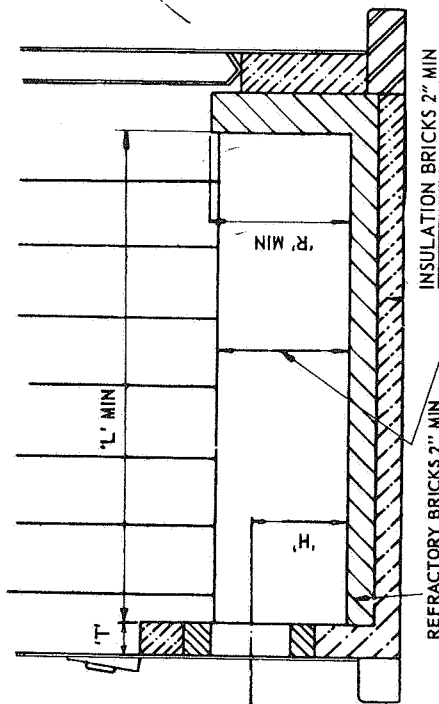

TYPICAL CROSS SECTION
W/WAY FIREBARS BOILER.

2 HOLES DRILL AND
TAP 1/2" WHIT.

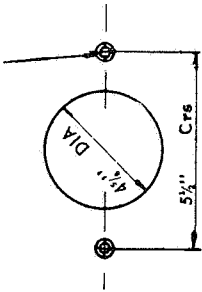

FRONT PLATE DRILLING
DETAILS FOR ZL2, ZL2D AND ZL11 H/L
BURNER

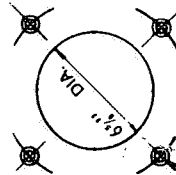

4 HOLES DRILL AND
TAP 1/2" WHIT ON 7 3/4" P.C.D.

FRONT PLATE DRILLING DETAILS
FOR ZL11, ZL11 L.F.S., ZL11 H/L BURNER

BURNER	RATE OF FIRING U.S.G.P.H.	BURNER SIZE REF.	QUARL BLOCK DRG. No.	'L' MIN	'L' MAX	'W' MIN	'T'	'H'	'R' MIN	'Q'	'X'
ZL2	.55/1.71	A	DD293/1	6"8"	MAX	6"	3"	3 1/2"	7"	6"	4 1/2"
	.72/1.00	B	DD293/1	10"		8"	3"	4 1/2"	9"	6"	4 1/2"
	1.01/1.40	B	DD293/1	14"		8"	3"	6"	12"	6"	4 1/2"
	1.41/1.80	C	DD293/1	16"		9"	3"	6"	12"	6"	4 1/2"
	1.81/2.25	T	DD293/1	18"		9"	3"	6"	12"	6"	4 1/2"
ZL2D	2.26/3.00	A	DD293/1	18"		10"	3"	7"	12"	6"	4 1/2"
	3.01/3.60	A	DD293/1	20"		12"	3"	7"	12"	6"	4 1/2"
	3.61/4.20	B	DD293/1	20"		12"	3"	8"	13 1/2"	6"	4 1/2"
	4.21/4.80	B	DD293/1	22"		14"	3"	8"	13 1/2"	6"	4 1/2"
	4.81/5.50	B	DD293/1	24"		14"	3"	8"	13 1/2"	6"	4 1/2"
	5.51/6.40	C	DD293/1	26"		16"	3"	9"	15"	6"	4 1/2"
	6.41/7.40	C	DD293/1	30"		16"	3"	9"	15"	6"	4 1/2"
	7.41/8.50	C	DD293/1	36"		18"	3"	10"	15"	6"	4 1/2"
ZL11	8.6/9.9	A	E8268/2	40"		20"	4 1/2"	10"	15"	9"	5 1/2"
	10.0/11.5	A	E8268/2	45"		22"	4 1/2"	10"	15"	9"	5 1/2"
	11.6/12.8	B	E8268/2	50"		24"	4 1/2"	12"	18"	9"	5 1/2"
	12.9/14.2	B	E8268/2	55"		24"	4 1/2"	12"	18"	9"	5 1/2"
	14.3/16.0	C	E9141	60"		26"	4 1/2"	14"	21"	9"	6 1/2"
	16.1/17.8	C	E9141	65"		26"	4 1/2"	14"	21"	9"	6 1/2"

ALL DIMENSIONS ARE IN INCHES

TITLE
COMBUSTION CHAMBER
DETAILS FOR STD ZL2, ZL2D
& ZL11 BURNERS
FITTED WITH DIFFUSER
TYPE COMBUSTION HEADS

DRG. No. DD 1143

NU-WAY HEATING PLANTS LTD.
DROITWICH
WORCS.
DATE 26.5.66

Leading Dimensions

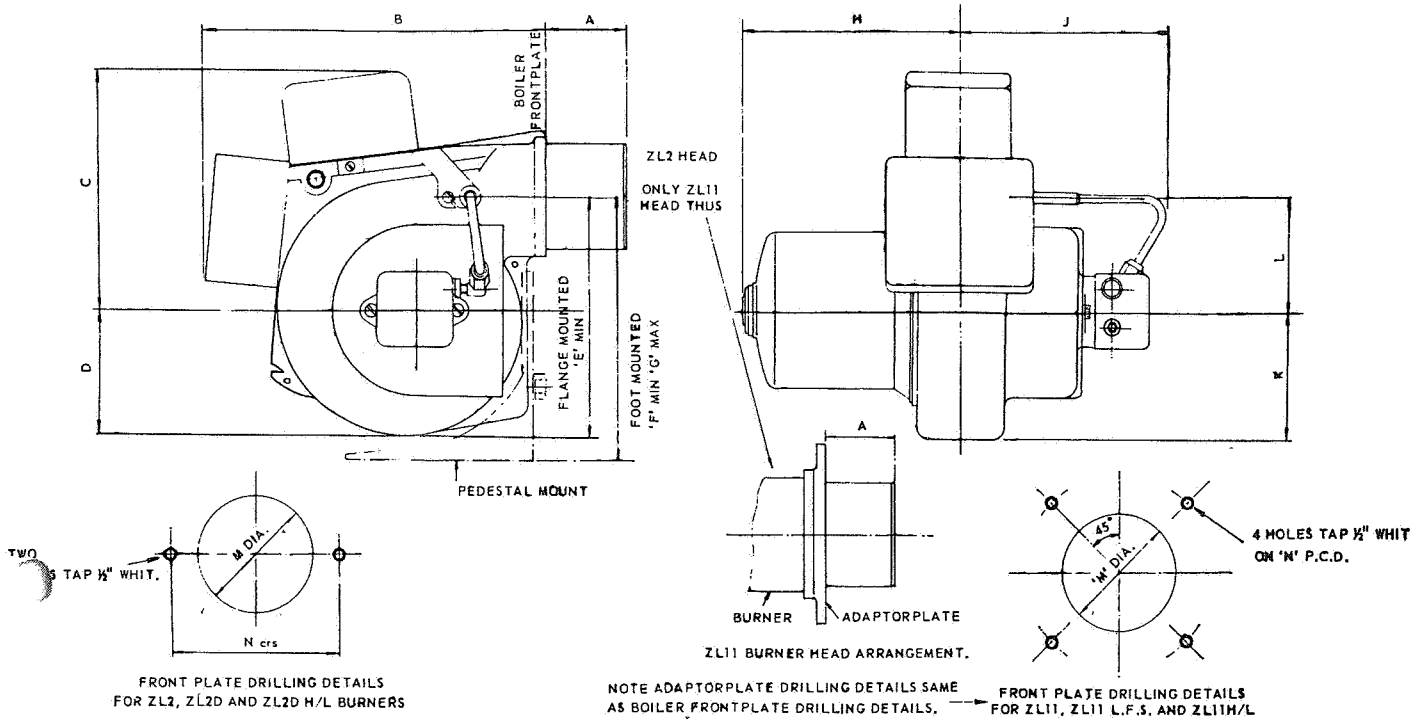

Model	A	B	C	D	E	F	G	H	J	K	L	M	N	Nett * Weight
ZL2	3 $\frac{3}{8}$ "	14 $\frac{1}{2}$ "	9 $\frac{1}{2}$ "	5"	9 $\frac{3}{8}$ "	9 $\frac{3}{8}$ "	13"	8 $\frac{1}{2}$ "	7 $\frac{1}{2}$ "	5"	4 $\frac{1}{8}$ "	4 $\frac{1}{8}$ "	5 $\frac{1}{2}$ "	55 lb.
ZL2D	3 $\frac{3}{8}$ "	14 $\frac{1}{2}$ "	10"	5"	9 $\frac{3}{8}$ "	9 $\frac{3}{8}$ "	13"	10 $\frac{1}{2}$ "	7 $\frac{1}{2}$ "	5"	4 $\frac{1}{8}$ "	4 $\frac{1}{8}$ "	5 $\frac{1}{2}$ "	65 lb.
ZL2D H/L	3 $\frac{3}{8}$ "	14 $\frac{1}{2}$ "	10"	5"	9 $\frac{3}{8}$ "	9 $\frac{3}{8}$ "	13"	10 $\frac{1}{2}$ "	7 $\frac{1}{2}$ "	5"	4 $\frac{1}{8}$ "	4 $\frac{1}{8}$ "	5 $\frac{1}{2}$ "	75 lb.
ZL11	5 $\frac{3}{8}$ "	17 $\frac{7}{8}$ "	10 $\frac{3}{8}$ "	5"	9 $\frac{3}{8}$ "	16 $\frac{1}{2}$ "	19 $\frac{1}{2}$ "	13"	9 $\frac{1}{2}$ "	5"	4 $\frac{1}{2}$ "	6 $\frac{1}{8}$ "	7 $\frac{3}{8}$ "	90 lb.
ZL11 L.F.S.	5 $\frac{3}{8}$ "	17 $\frac{7}{8}$ "	10 $\frac{3}{8}$ "	5"	9 $\frac{3}{8}$ "	16 $\frac{1}{2}$ "	19 $\frac{1}{2}$ "	13"	9 $\frac{1}{2}$ "	5"	4 $\frac{1}{2}$ "	6 $\frac{1}{8}$ "	7 $\frac{3}{8}$ "	90 lb.
ZL11H/L	5 $\frac{3}{8}$ "	17 $\frac{7}{8}$ "	10 $\frac{3}{8}$ "	5"	9 $\frac{3}{8}$ "	16 $\frac{1}{2}$ "	19 $\frac{1}{2}$ "	13"	9 $\frac{1}{2}$ "	5"	4 $\frac{1}{2}$ "	6 $\frac{1}{8}$ "	7 $\frac{3}{8}$ "	90 lb.
ZL11H/L	5 $\frac{3}{8}$ "	17 $\frac{7}{8}$ "	10 $\frac{3}{8}$ "	5"	9 $\frac{3}{8}$ "	16 $\frac{1}{2}$ "	19 $\frac{1}{2}$ "	13"	9 $\frac{1}{2}$ "	5"	4 $\frac{1}{2}$ "	6 $\frac{1}{8}$ "	7 $\frac{3}{8}$ "	90 lb.

* Approx.

Burner Electric Loadings

Burner Model	Motor H.P.	Start Current Amps 1 Phase	Run Current Amps 1 Phase	Start Current Amps 3 Phase	Run Current Amps 3 Phase
ZL2	1/10	7.5	1.2	2.0	0.3
ZL2D	1/3	17.0	3.2	3.0	0.7
ZL2DH/L	1/3	17.0	3.2	3.0	0.7
ZL11	3/4	25.0	5.0	7.5	1.8
ZL11 LFS	3/4	25.0	5.0	7.5	1.8
ZL11 H/L	3/4	25.0	5.0	7.5	1.8

General Information

Ignition

Each burner is equipped with an intermittent 10,000 v. transformer fitted with a centre tap to earth. T.V. suppressed.

Motors

"ZL" burners can be supplied for either single or three phase 50 cycles A.C. Burners for D.C. can be supplied to special order.

Fuel

All ZL Models are designed to burn distillate oils of a viscosity not exceeding 43 seconds Redwood No. 1 at 100°F. This is equivalent to 1 $\frac{1}{2}$ ° Engler, 48 seconds Saybolt Universal and 6.5 Centistokes, all at 100°F. or 38°C.

Fuel Unit

Sundstrand 1-stage, or Danfoss.

Burner Mounting

All burners are supplied for flange mounting.

Filters

Pump strainer and sintered bronze nozzle filter.

Finish

Silver Grey Hammer (ZL2). Blue Hammer (ZL11).

Standard MODEL ZL Burners - Capacities, Nozzle/Air Handling Part Data etc.

(1) MODEL ZL Burners with ON/OFF Control.

MODEL NO.	A.H.P. Size.	Nozzle(s) Marking U.S. gph.	Nett Output @ Boiler Eff. 75% BTU/Hr.	Air Cone or End Ring Int. Dia.	Restrictor Int. Dia. (ZL2 only)	NOTES.
ZL 2	"A"	0.5 to 0.6	57,000 - 69,000	2 1/4"	3"	1) Nozzle Type : Monarch "R". 2) Spray Angle : 45° 3) Pump Press : 125 p.s.i. 4) Pump: Danfoss RS 40 or Sundstrand J3. 5) Draught Tube: 3 1/2" Projection.
	"B"	0.65 to 1.2	75,000 - 137,000	2 1/4"	3 1/2"	
	"C"	1.25 to 1.5	143,000 - 172,000	3 1/8"	3 1/8"	
	"T"	1.65 to 2.0	188,000 - 230,000	3 1/8"	None	
ZL2D	"A"	1.65 to 3.0	200,000 - 363,000	3 1/2"	(1) Nozzle :- Size "A" Monarch R. Sizes "B" & "C" " PLP. (2) Spray Angle: 60°. (3) Pump Press: 140 p.s.i. (4) Pump: Danfoss RS 40 or Sundstrand J3 (5) Draught Tube :- 3 1/2" Projection.	
	"B"	3.5 to 4.5	424,000 - 545,000	3 5/8"		
	"C"	5.0 to 7.0	605,000 - 850,000	4"		
ZL11	"A"	7.5 to 9.5	910,000 - 1,150,000	5 1/8"	(1) Nozzle :- Monarch PLP. (2) Spray Angle 60°. (3) Pump Press: 140 p.s.i. (4) Pump: Danfoss RS 60 or Sundstrand J4 (5) ZL11 "C" has Low Fire Start & enlarged draught tube. (6) Draught Tube & Diffuser Sizes "A" & "B" - 6" Projection Size "C" - 7" Projection *Diffuser 1/2" in front of DT face - Size "B" only.	
	"B"	10.5 to 12.0	1,270,000 - 1,450,000	5 1/8" (6)		
	"C"	6.5+6.5 to 7.5+7.5	1,570,000 - 1,820,000	6"		

NOTE: This information does not necessarily apply to ZL Burners prepared to OEM Specification.

Standard MODEL ZL Burners - Capacities, Nozzle/Air Handling Part Data etc.

(2) MODEL ZL Burner with HIGH/LOW/OFF Control.

MODEL NO.	A.H.P. Size.	Nozzle(s) Marking U.S. gph.	Nett Output @ Boiler Eff. 75% BTU/Hr.	Air Cone or End Ring Int. Dia.	NOTES.
ZL2D H/L	"B"	2.0 + 2.0 to 2.25 + 2.25	485,000 - 545,000	3 1/8"	1) Nozzles Monarch R. 2) Spray Angle 60°. 3) Pump Pressure : 140 p.s.i. 4) Pump: Danfoss RS 40. 5) Draught Tube: 3 1/2" Projection.
		"C"	2.5 + 2.5 or 3.0 + 3.0 or 3.5 + 3.5		
	ZL11 H/L	"A"	4.0 + 4.0 or 3.5 + 4.5 or 5.0 + 5.0	970,000 - 1,090,000 - 1,210,000	
"B"			5.5 + 5.5 to 6.0 + 6.0	1,330,000 - 1,450,000	5 1/8" (6)
"C"		6.5 + 6.5 or 7.0 + 7.0 or 7.5 + 7.5	1,570,000 - 1,700,000 - 1,820,000	6"	

NOTE: This information does not necessarily apply to ZL Burners prepared to OEM Specification.

NOZZLE THROUGHPUTS U.S. g.p.h.		
≥ 100 psi.	@ 125 psi.	≥ 140 psi.
0.5	0.55	-
0.6	0.65	-
0.65	0.73	-
0.75	0.82	-
0.85	0.95	-
1.0	1.1	-
1.1	1.23	-
1.2	1.34	-
1.25	1.38	-
1.35	1.51	-
1.5	1.65	-
1.65	1.84	-
1.75	1.93	2.1
2.0	2.2	2.4
2.25	2.51	2.7
2.5	2.75	3.0
3.0	3.3	3.6
3.5	3.8	4.2
4.0	4.4	4.8
4.5	4.95	5.4
5.0	5.5	6.0
5.5	6.0	6.6
6.0	6.6	7.2
6.5	7.15	7.8
7.0	7.7	8.4
7.5	8.25	9.0
8.0	8.8	9.6
8.5	9.35	10.2
9.0	9.9	10.7
9.5	10.5	11.4
10.0	11.0	12.0

Notes:

- (1) Nozzles Calibrated at 100 psi Throughput @ 100 p.s.i. = "Nozzle Marking"
- (2) To convert US to Imperial Gallons Multiply x $\frac{5}{6}$

BOILER OUTPUT/FIRING RATE - ZL2D & ZL11 BURNERS

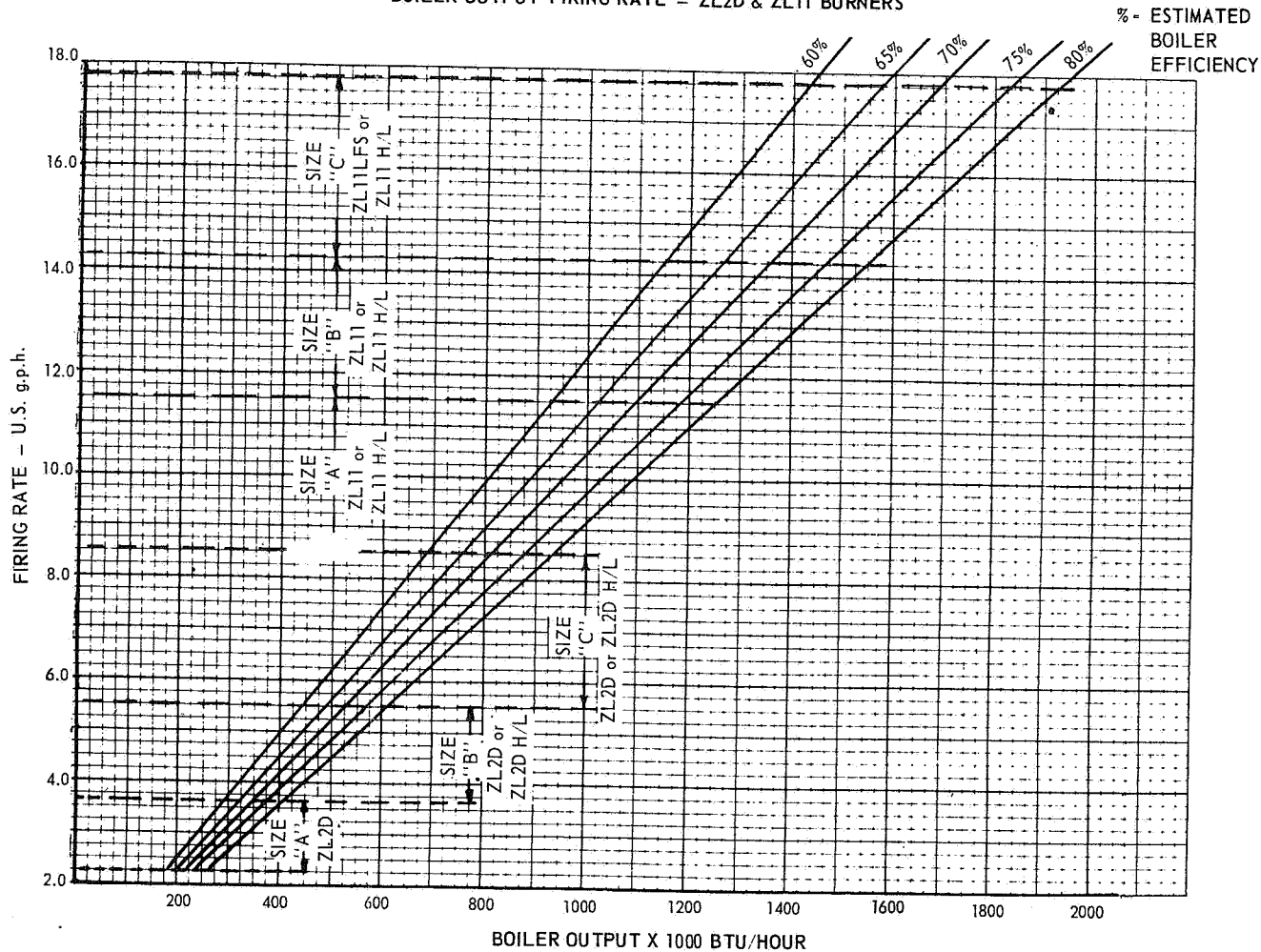

BOILER OUTPUT/FIRING RATE - MODEL ZL2 BURNERS

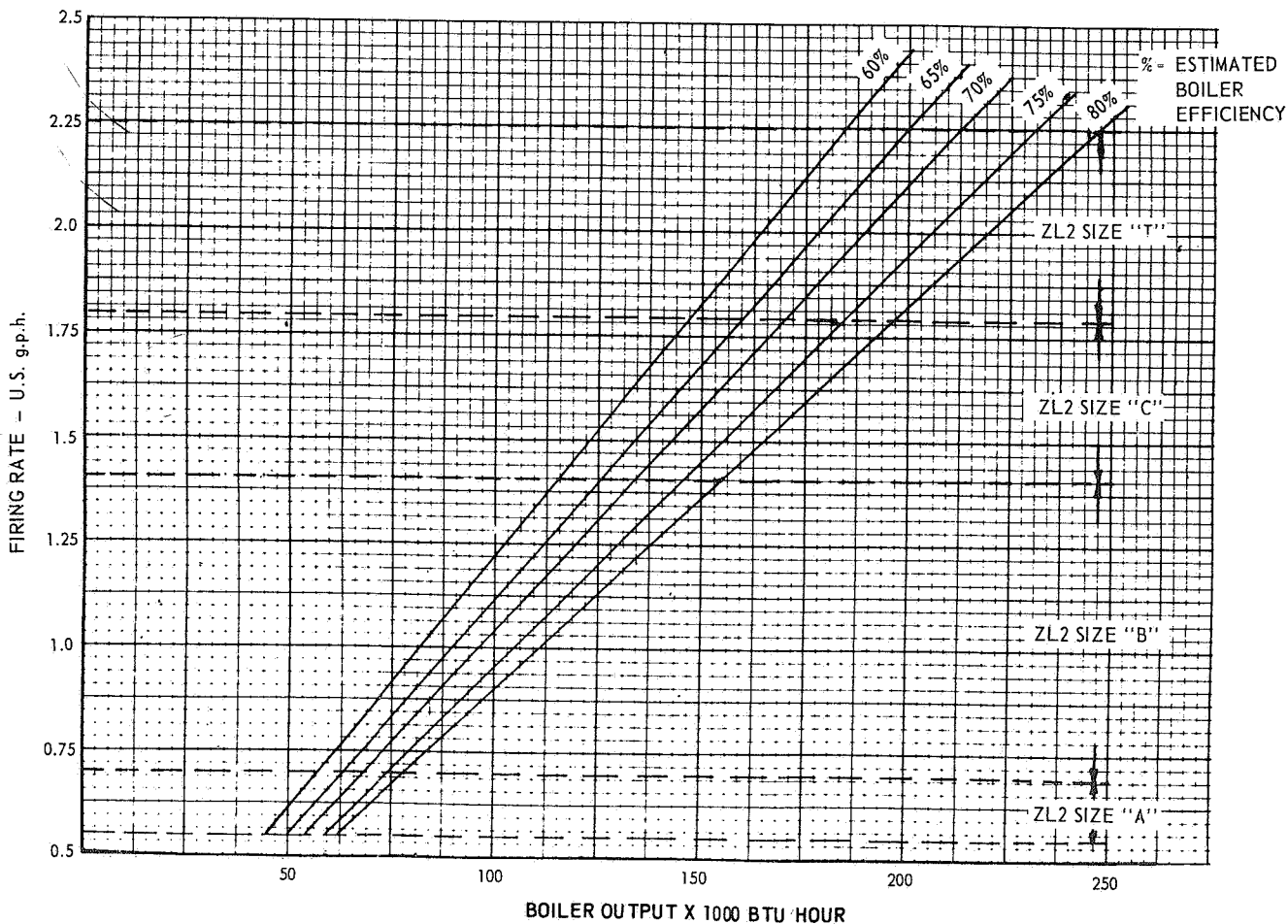

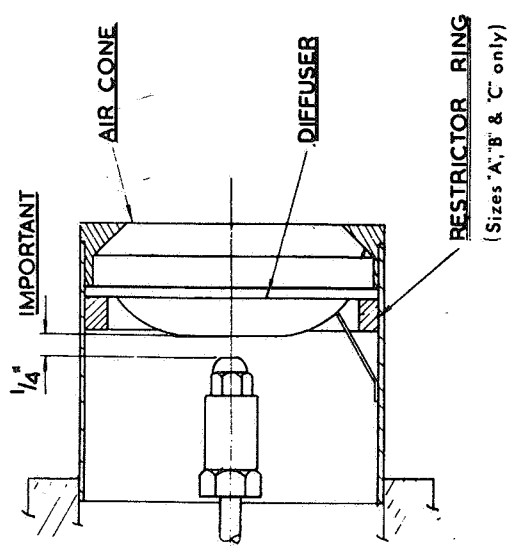
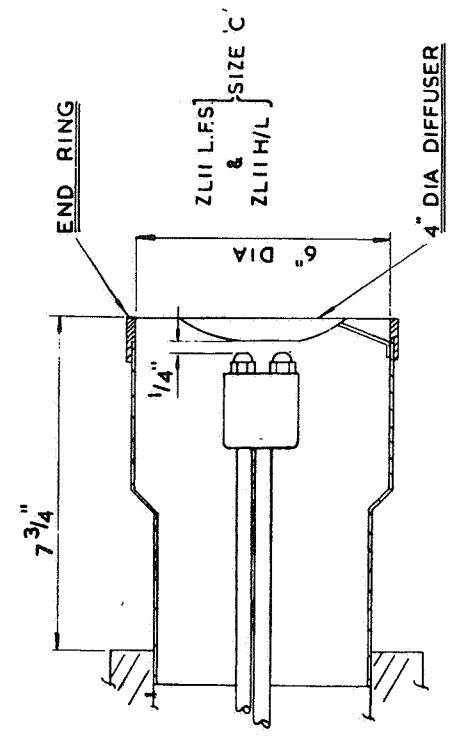
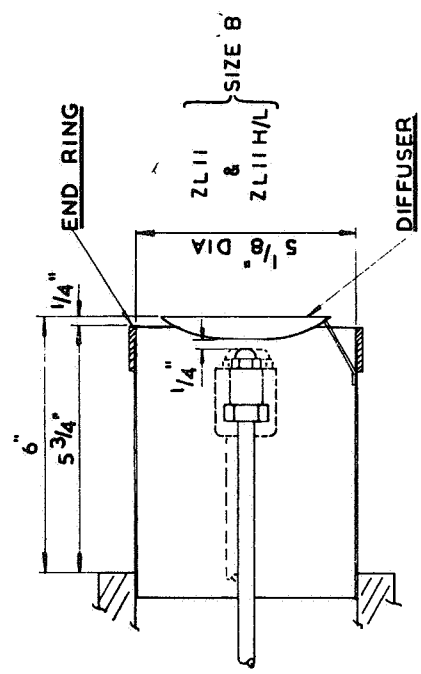
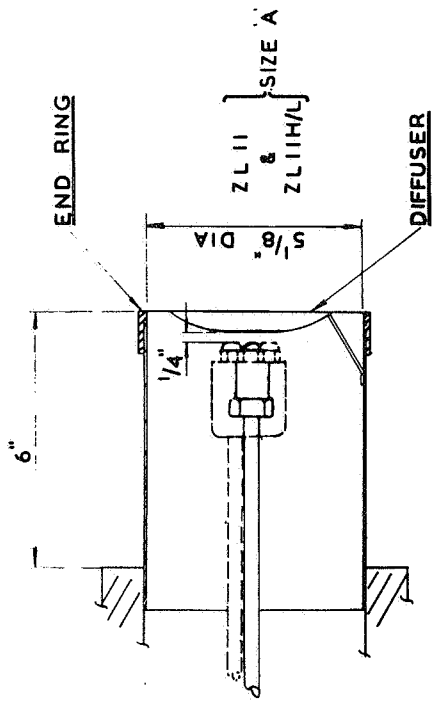

ZL 2

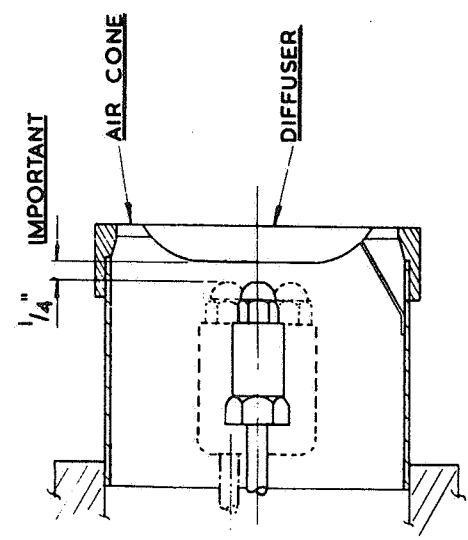

ZL 2D & ZL 2D H/L

STANDARD AIR HANDLING PART ARRANGEMENTS FOR "ZL" BURNERS



SUNDSTRAND FUEL UNITS

Installation Information

MODELS J & H

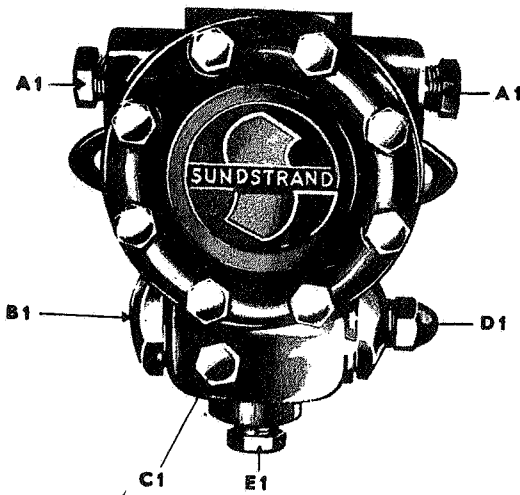

One-pipe installation

Fig. 1

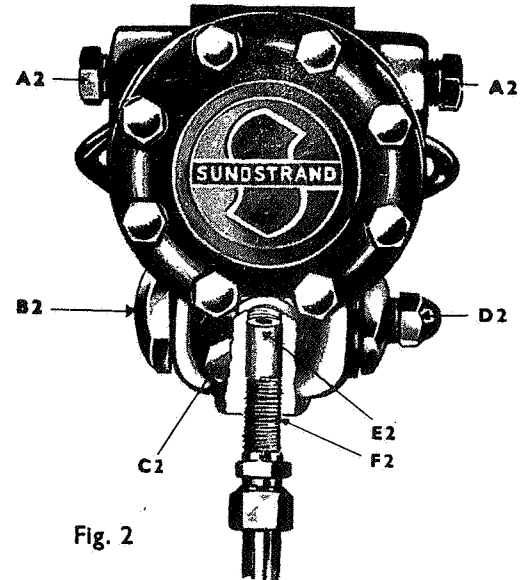

Fig. 2

Two-pipe installation

INSTALLATION INFORMATION

Model J one stage and model H two stage

NOTE: This unit may be used on either one-pipe or two-pipe systems. It is delivered from the factory with the internal by-pass plug left out and is, therefore, ready to be installed on a one-pipe system.

All Sundstrand standard fuel units are delivered from the factory with pressure set at 100 P.S.I. Pumps with pressure adjusting spring type B or C are delivered with pressure set at 145 P.S.I. Should it be necessary to change this pressure refer to D1 and D2 below. Use pipe dope or thread sealer on all fittings and pipe plugs.

CAUTION: Where a one-pipe system is used the fuel unit must be located lower than the bottom of the tank.

NOTE: Intake line cannot be used to more than one fuel unit unless oil tank is higher than both pumps and tee

FIG. 1

- A 1. INTAKE PORTS. Use either side for intake line fitting. (1/4" NPTF-thread.)
- B 1. NOZZLE PORT. 1/8" NPTF fitting.
- C 1. GAUGE PORT. 1/8" NPTF fitting.
- D 1. TO REGULATE PRESSURE. First remove cap, then, to increase pressure, turn screw clockwise. To decrease pressure turn screw counter-clockwise
- E 1. RETURN PORT PLUG. Tighten this plug securely.

INSTRUCTION:

1. Remove one of the 1/4" NPTF-plugs and assemble the intake line fitting there
2. Connect nozzle line into B1.
3. Tighten return port plug securely. (Use only box or socket wrench).
4. Before starting burner, be sure to bleed air out of the system by loosening unused intake port plug (plug opposite to one into which intake line is assembled) until there is a flow of oil out of port. Then tighten plug securely. Burner is now ready for operation.

FIG. 2

- A 2. INTAKE PORTS. Use either side for intake line fitting. (1/4" NPTF-thread.)
- B 2. NOZZLE PORT. 1/8" NPTF fitting.
- C 2. GAUGE PORT. 1/8" NPTF fitting.
- D 2. TO REGULATE PRESSURE. First remove cap nut, then, to increase pressure turn screw clockwise. To decrease pressure turn screw counter-clockwise.
- E 2. BY-PASS PLUG. (Packed in the plastic-bag.)
- F 2. RETURN PORT. Connect return line here using 1/4" NPTF fitting.

INSTRUCTION:

1. Remove one of the 1/4" NPTF-plugs and assemble the intake line fitting there.
2. Connect nozzle line into B2.
3. Unscrew return port plug and insert "by-pass" plug as shown in Fig. 2, and tighten securely.
4. Assemble return line fittings in return port.
5. Tighten the 1/4" NPTF-plug in unused intake port. (Use box or socket wrench only).
6. On two-pipe system, air bleeding is automatic.

Two-pipe installation

IMPORTANT: Model H with revision No. 4 (ex.: H6BC-100-4), may be mounted on the burner in three positions, as shown in FIG. A, B and C. H-units with a revision No. lower than -4 must, however, be mounted with return port at bottom, as shown in FIG. A.

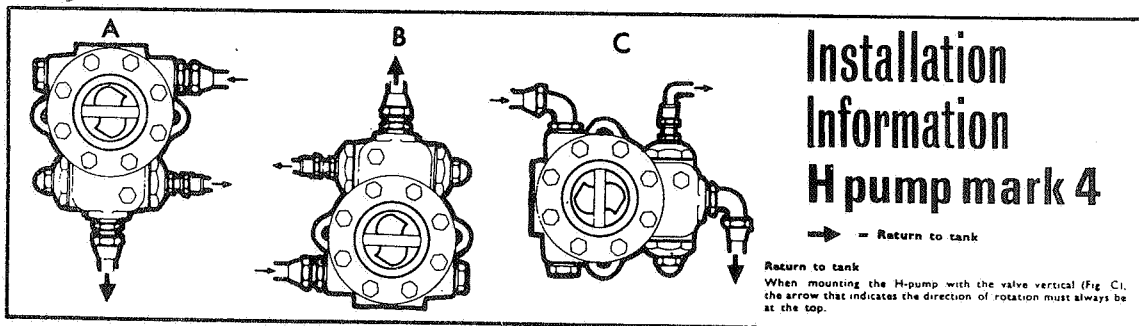

Installation Information

H pump mark 4

→ - Return to tank

Return to tank
When mounting the H-pump with the valve vertical (Fig. C), the arrow that indicates the direction of rotation must always be at the top.



ANGLO-NORDIC BURNER PRODUCTS LTD.

74 LONDON ROAD KINGSTON-UPON-THAMES, SURREY.

TELEPHONE: KINGSTON 1133/4/5 Telex: 28565

Cables and Telegrams: Oiloparts Kingston-upon-Thames



HOW TO DETERMINE THE CORRECT LINE SIZE FOR SUNDSTRAND FUEL UNIT INSTALLATION

NOTE
DO NOT USE LESS THAN 3/8" O.D. TUBING

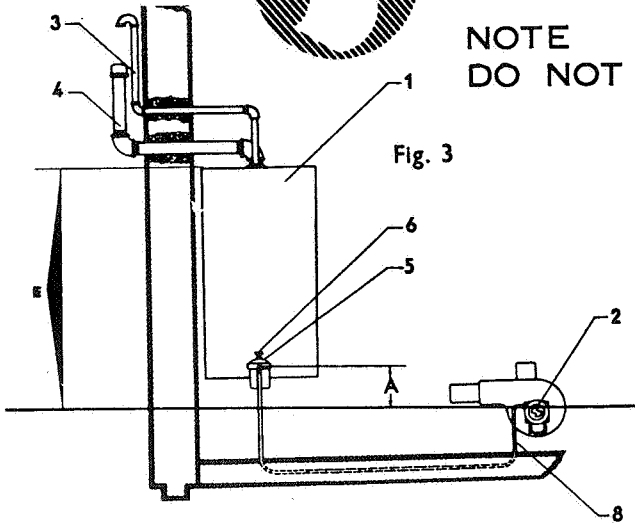

Fig. 3

Fig. 3 LINE SIZE FOR ONE PIPE INSTALLATION

Use the system shown in FIG. 3 only with *inside* tank where fuel unit is below bottom of tank. Distance "E" from top of oil tank to fuel unit should not exceed 12 feet.

Maximum allowable length of intake line in feet. (Includes horizontal and vertical run)

Distance "A"	3/8" O.D. Tubing						1/2" O.D. Tubing					
	Firing rate in gph						Firing rate in gph					
	1	3	6	10	14	20	1	3	6	10	14	20
0'	+	62'	33'	19'	13'	10'	+	+	125'	75'	52'	39'
1'	-	85'	43'	26'	19'	13'	-	-	102'	72'	52'	39'
2'	-	111'	56'	33'	23'	16'	-	-	131'	92'	66'	49'
3'	-	134'	66'	39'	29'	20'	-	-	150'	111'	79'	59'
4'	-	150'	79'	46'	33'	23'	-	-	150'	131'	92'	66'
5'	+	150'	88'	52'	39'	26'	+	+	150'	150'	105'	79'

Fig. 4

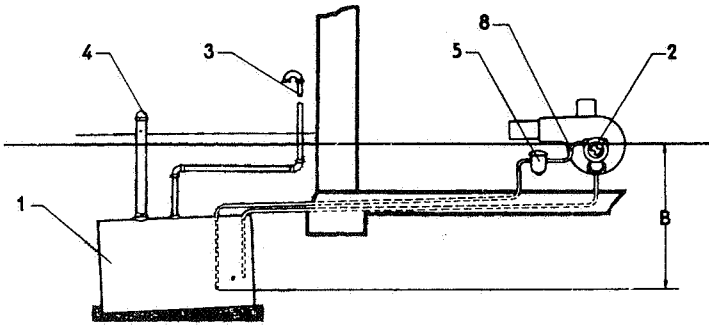

Fig. 4 LINE SIZE FOR TWO-PIPE INSTALLATION

Maximum allowable length of either intake or return line in feet. (Includes horizontal and vertical run)

Inside or outside tank. Fuel Unit ABOVE tank

Distance "B"	3/8" O.D. Tubing						1/2" O.D. Tubing						
	J3	J4	J6	H3	H4	H6	J3	J4	J6	H3	H4	H6	H7
0'	62'	52'	30'	89'	79'	56'	230'	190'	115'	322'	292'	213'	121'
1'	59'	49'	30'	89'	75'	55'	213'	174'	105'	312'	279'	203'	115'
2'	56'	43'	26'	82'	72'	52'	199'	161'	98'	299'	269'	199'	112'
3'	49'	39'	23'	79'	69'	49'	180'	148'	89'	289'	259'	190'	105'
4'	43'	36'	20'	75'	66'	49'	164'	135'	82'	276'	249'	180'	102'
5'	39'	33'	20'	72'	62'	46'	148'	121'	72'	266'	239'	174'	99'
6'	36'	30'	16'	69'	59'	43'	131'	108'	67'	253'	226'	167'	95'
7'	30'	23'	13'	66'	56'	43'	112'	99'	56'	240'	217'	157'	87'
8'	26'	20'	13'	62'	52'	39'	96'	82'	46'	230'	207'	151'	85'
9'	20'	16'	-	59'	49'	39'	82'	67'	39'	217'	194'	141'	79'
10'	16'	13'	-	56'	46'	36'	62'	49'	33'	207'	184'	135'	75'
11'	-	-	-	52'	46'	33'	46'	-	-	194'	174'	128'	72'
12'	-	-	-	49'	43'	30'	26'	-	-	180'	164'	118'	69'
13'	-	-	-	46'	39'	30'	-	-	-	171'	151'	112'	62'
14'	-	-	-	43'	36'	26'	-	-	-	157'	141'	102'	59'
15'	-	-	-	39'	33'	23'	-	-	-	148'	131'	95'	56'

Fig. 5 LINE SIZE FOR TWO-PIPE INSTALLATION

Inside or outside tank. Fuel unit BELOW tank

Maximum allowable length of either intake or return line in feet. (Includes horizontal and vertical run)

Distance "C"	3/8" O.D. Tubing							1/2" O.D. Tubing						
	J3	J4	J6	H3	H4	H6	H7	J3	J4	J6	H3	H4	H6	H7
0'	59'	46'	30'	82'	72'	52'	30'	230'	190'	115'	322'	292'	213'	118'
1'	62'	52'	30'	85'	75'	56'	30'	246'	203'	121'	335'	302'	220'	125'
2'	67'	56'	33'	89'	79'	56'	33'	262'	217'	131'	348'	312'	230'	128'
3'	69'	59'	36'	89'	82'	59'	33'	279'	230'	141'	358'	322'	236'	131'

KEY TO DIAGRAMS

- 1 Oil tank
- 2 Fuel unit
- 3 Air Vent
- 4 Fill pipe
- 5 Aux filter
- 6 Shut-off valve
- 7 Shut-off valve
- 8 Intake

NOTE:

A Use the system shown in Figure 3 only with *inside* tank where fuel unit is below bottom of tank. Distance from top of oil tank to fuel unit should not exceed 12 feet.

B One supply line from a single oil tank may be teed to two or more burners, only if the bottom of the tank is higher than both fuel units and the connecting tee. Size the supply line for total of firing rates and run horizontally below bottom of tank. If the tank is not above both pumps and the connecting tee, an elevated automatic wall pump may be used, or otherwise each burner will require a separate intake and return line.

With single pipe installations, horizontal runs should be located below bottom of tank due to bleeding difficulties which otherwise result.

Always terminate return line about six inches above end of suction line.

One of the Anglo-Nordic QUALITY Products

E INSTRUCTIONS

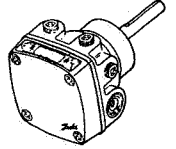

Compact Oil Pump Type RS

1 Check direction of rotation which is shown by the arrow on the data plate. ("Right-hand pumps" rotate clockwise and "Left-hand pumps" rotate anti-clockwise. Look towards shaft end.)

2 Mount the pump. It can be mounted as shown below, but it is advisable to use position a; if this is not possible, then position b and so on.

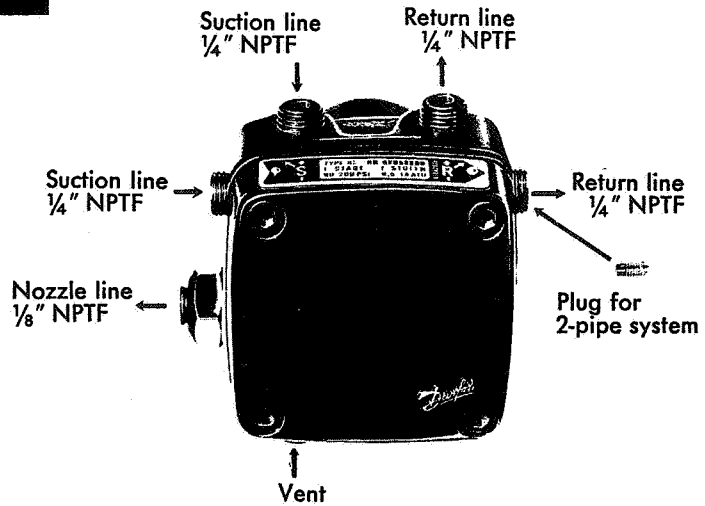

Different ways of mounting

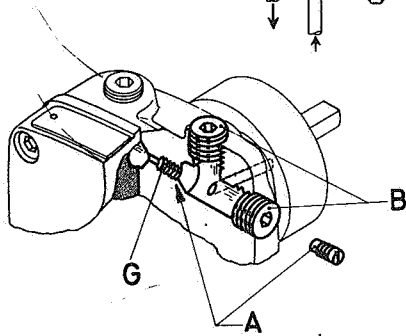
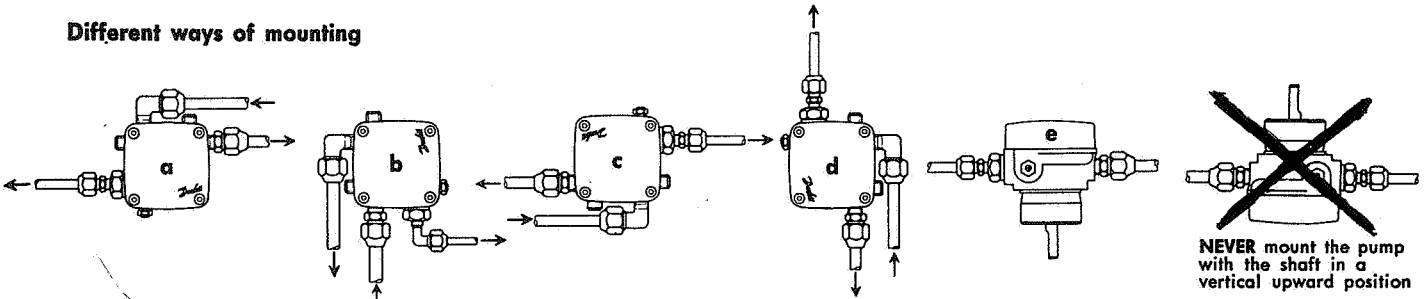

3 Arrangement for 1-pipe or 2-pipe system
CHECK! When supplied, RS is always arranged for 1-pipe system.
 If the pump is to be used for a 2-pipe system the plug, "A" must be fitted, and the return line be connected to one of the connections "B".

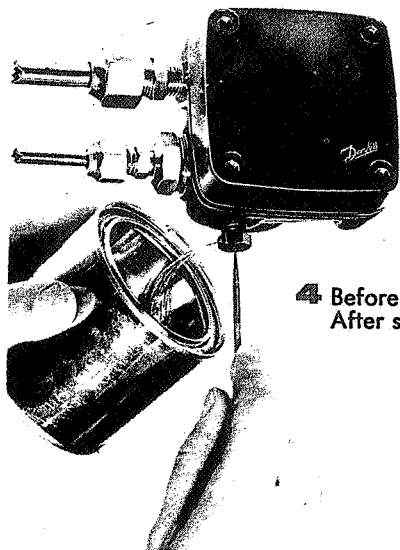

4 Before start-up: Check direction of rotation of motor.
 After start-up: Vent the pump, nozzle tube and nozzle.

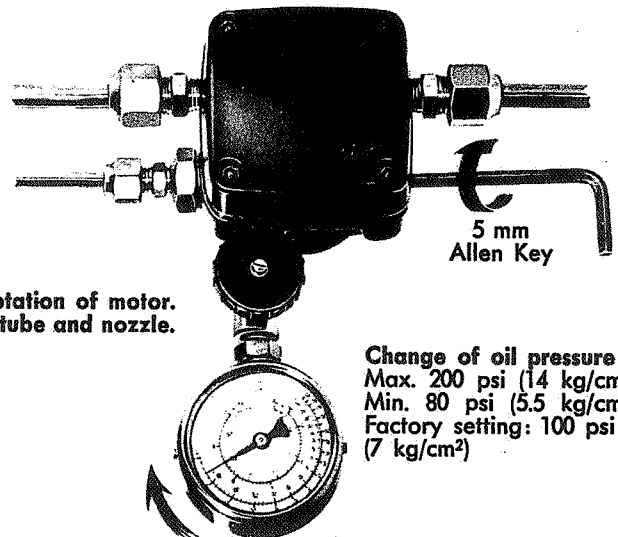

Max. lengths of suction line

1-pipe system
used only when the oil feed is constantly under positive pressure.

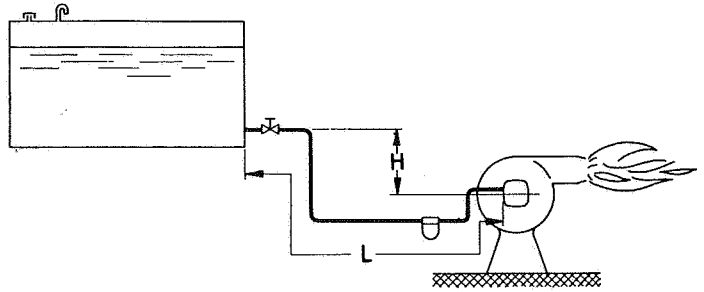
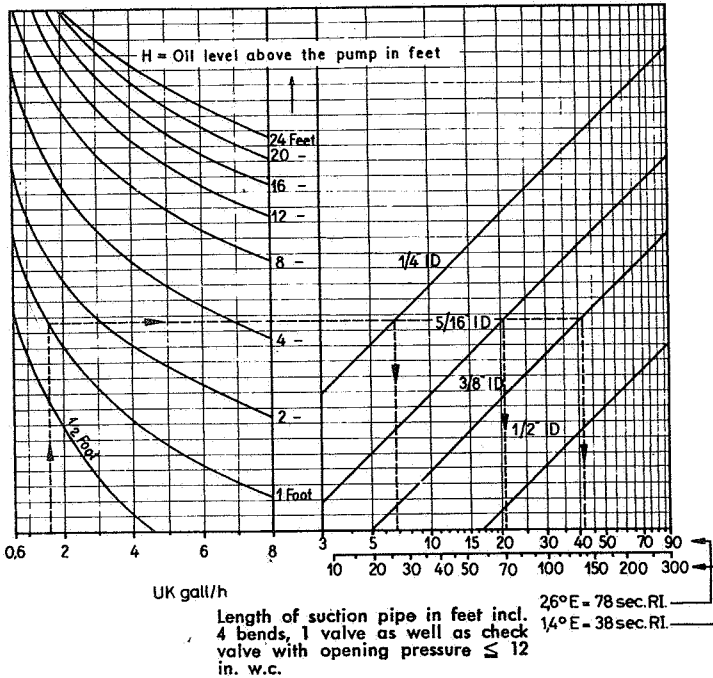

Example: (see dotted lines in diagram).

Nozzle capacity = 1.5 gall/h. Oil level above pump = 1 ft.

In that case it is possible to use:

- 1/4 in I.D. piping max. 7 ft.
- 5/16 in I.D. piping max. 21 ft.
- 3/8 in I.D. piping max. 40 ft.
- with oil at 78 sec. R 1 (2.6°E).

2-pipe system
used when a vacuum may occur in the suction line.

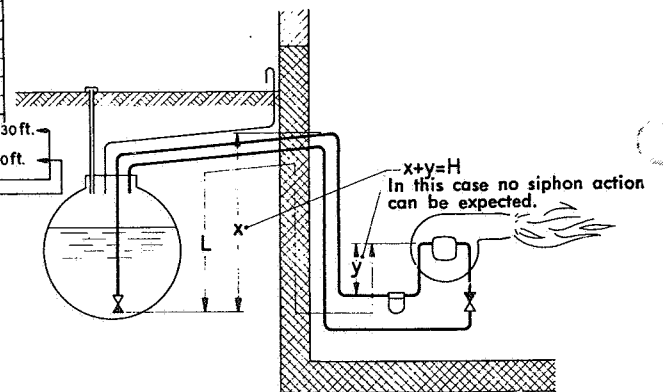
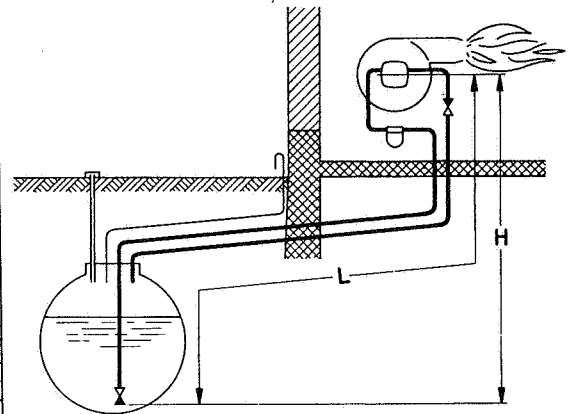
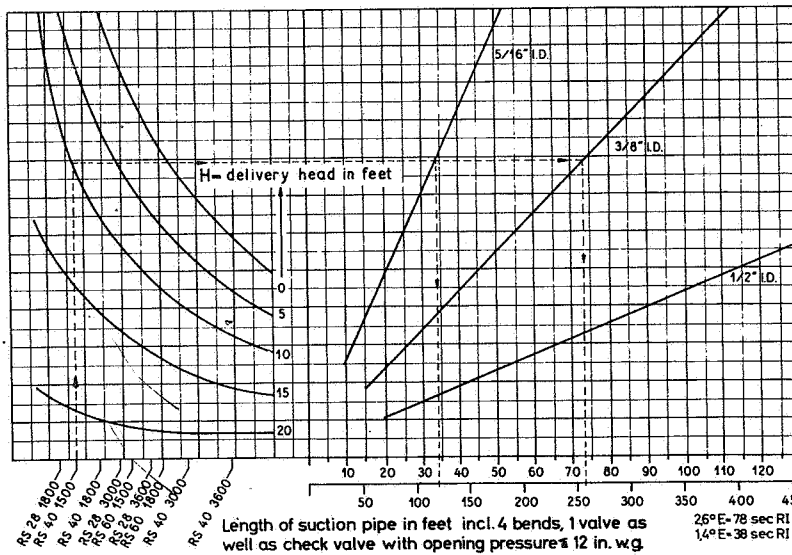

Ordering Table

Type	Colour of data plate	Direction of rotation (as viewed towards shaft end)	Code No.	
			Dimension of shaft	
			10 mm	7/16"
RS	28	green clockwise anti-clockwise	70-5300 70L5300	70-5310 70L5310
	40	blue clockwise anti-clockwise	70-3200 70L3200	70-3210 70L3210
	60	brown clockwise anti-clockwise	70-3300 70L3300	70-3310 70L3310
Mounting flange with four screws			70-0211	

Example: (see dotted lines in diagram).

RS 40 - 1500 rev/min with suction lift H = 10 ft.

For 78 sec. R 1 (2.6°E) it is then possible to use:

- 5/16 in I.D. piping max. 34 ft.
- 3/8 in I.D. piping max. 74 ft.
- and with oil at 38 sec. R 1 (1.4°E).
- 5/16 in I.D. piping max. 120 ft.
- 3/8 in I.D. piping max. 250 ft.



AUTOMATIC CONTROLS AND EQUIPMENT
NORDBORG . DENMARK

NU-WAY FULLY AUTOMATIC LIGHT OIL BURNER

Operating Instructions

(HANG NEAR BURNER)

THESE INSTRUCTIONS ARE PROVIDED FOR THE BENEFIT OF THE OPERATOR AND ARE INTENDED TO BE OF ASSISTANCE IN MAKING MINOR ADJUSTMENTS AND PROVIDING THE BURNER WITH PROPER MAINTENANCE CLEANING AND LUBRICATION. ADDITIONAL INFORMATION CAN BE OBTAINED THROUGH YOUR INSTALLER FROM THE MANUFACTURER.

FUEL

The unit is designed to burn any light distillate oil having a viscosity not exceeding 43 Seconds Redwood No. 1 at 100°F. DO NOT ATTEMPT TO USE PETROL, CRANK-CASE OIL OR ANY OIL WHICH MAY CONTAIN TRACES OF PETROL.

STARTING AND STOPPING.

Start the burner by setting the thermostat pointer to a figure which is higher than the room or water temperature. Stop the burner by setting the thermostat to a point below this temperature.

The burner may set itself in the "Safety-Lockout" position - this will occur if the burner stops through any other reason than the action of the thermostat - and must then be re-started by pressing the re-set button on the flameguard/sequence control. Ask your installer to instruct you in the proper method of re-setting. Do not attempt to re-set more than once every 30 minutes. If more frequent re-setting becomes necessary, call the service man whose name and address should be inserted below.

Do not attempt to start the burner when the fire-box may be full of oil vapour. It is desirable to allow the furnace to cool for about 15 minutes before re-setting the control to re-start the burner from "locked-out" position.

EMERGENCY STOP.

The burner can be stopped in emergency by opening the wall switch provided on the line between the burner and the electric supply. The installer must identify this switch.

CHECKING BURNER OPERATION.

Inspect burner flame periodically, if it becomes lop-sided or smoky, call the service man.

When cleaning the room housing the heater unit, always switch off the burner to reduce the amount of dust and lint drawn in through the air inlet.

SUMMER CARE-AUTUMN RESTART.

During the Summer months, or whenever heat is not required over a considerable period, the wall switch may be opened. To re-start the burner it is only necessary to close this switch.

At the beginning of the heating season have the furnace cleaned and flues swept. See that the complete burner plant, especially the electric ignition system, nozzle, oil filter etc., is checked over and cleaned by a competent service man.

OIL FILTRATION-SEDIMENT REMOVAL.

There is an oil strainer inside the body of the fuel pump and a separate oil filter between the oil pipe from the tank and the oil burner.

The oil strainer should be removed and cleaned with paraffin during the pre-season check-up. At the same time the oil filter cartridge should be replaced or cleaned, as appropriate for the type fitted. Vent fuel pump to remove any trapped air.

Draw off any accumulation of water or sediment in the fuel tank by opening the sludge cock in the tank bottom immediately before any new delivery of fuel. Do not run the burner while the tank is being re-filled and, if possible, do not re-start for one hour after re-filling is concluded.

CAUTION.

Never burn rubbish or refuse in the heater fire-box. Never leave waste paper or rags lying around near the burner or the heater.

INSTALLER

Name

Address

.....

.....

For Service Telephone:

Nights, Sundays or Holidays, Telephone:

.....