

# WINGCONE BURNER

SERIES "WC"

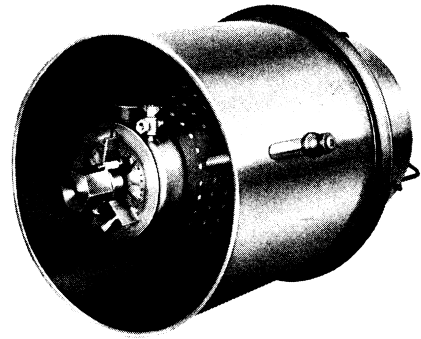
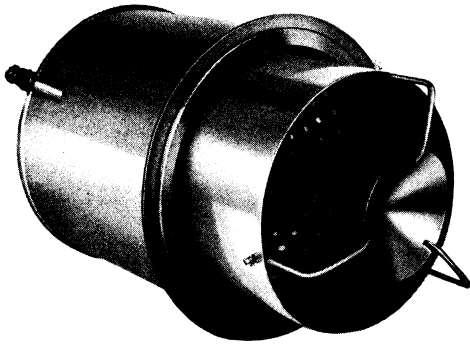

Wingcone Burners are combination gas/oil burners designed primarily for mounting in air ducts where all of the air required for combustion is available from the air stream which flows through and by the burner. They provide clean combustion throughout the entire operating range and 20 to 1 turndown on both gas and oil making them well suited for use in drying, curing, baking and other air heating processes which require clean, hot air, accurate temperature control and the versatility of dual fuel. Although the Wingcone burns cleanly, (tests indicate a smoke number of less than #1 Ringleman), U.S. Government rules prohibit the use of any oil burner on direct fired air makeup (comfort heating) systems.

Since the Wingcone uses air supplied by the system circulating fan, it does not require its own blower. This reduces cost, weight and maintenance and allows the burner to be mounted directly in the duct on the pressure or suction side of the fan. At least 6" of clearance must be provided between the outer burner shell and the duct. It can also be mounted outside the duct on the suction side of the fan, gap or sealed mounted and firing either with the airstream or perpendicular to it. When the burner is firing perpendicular to the airstream, the airstream velocity must not exceed 500 fpm. A diffuser plate at the front of the burner keeps the flame length short, making it possible to fit the Wingcone into most existing ducts. The flexibility of placement made possible by these features helps to keep piping layouts simple and holds down the cost of installation.

Mounting of the burner is provided for by a mounting ring welded to the discharge end of the outer burner shell. If specified, this ring can be shipped loose or mounted anywhere along the length of the outer burner shell. All parts of the burner which are exposed to the flame are constructed from 330 stainless steel.

## ADVANTAGES

- • • Dual fuel
- • • Light weight
- • • No combustion air blower
- • • Wide turndown range
- • • Clean burning

## OPERATION

Before operation can begin, certain conditions must be met. The air supplied by the system circulating fan must have at least an 18% O<sub>2</sub> content. The air temperature upstream of the burner must not exceed 400° F. and the downstream or chamber temperature, must not exceed 1000° F. The Wingcone is designed to operate most efficiently with a 1" w.c. pressure drop across the burner, however, it will perform satisfactorily with drops from .8" w.c. to 1.5" w.c. If the drop is below .8" w.c.

(3600 fpm), it will be necessary to profile the burner to achieve a 1" w.c. drop. If the drop is above 1.5" w.c. (4900 fpm), it will be necessary to reduce the air velocity to 4900 fpm or below.

The burner's oil nozzle is centered at the upstream end of the burner with a baffle ring and circular gas manifold around it. With the system circulating fan on, gas is allowed to flow to the raw gas pilot and is direct spark ignited. Once the pilot is established, the main fuel can be turned on. For pilot and low fire, all the air for combustion is drawn through the burner head and combustion occurs in the protected area in the center of the circular gas manifold and baffle ring. Once the main flame is established, the pilot can be shut off (interrupted). As the firing rate increases, the additional air required enters the open back of the burner, passes through holes in the burner cone and mixes with the fuel.

20 to 1 turndown can be achieved on gas by simply decreasing the gas flow from high fire. To realize this rate of turndown on oil, it is also necessary to modulate the atomizing air. A valve train for modulating the atomizing air as well as gas and oil valve trains can be obtained from Eclipse (see page 4). 20 to 1 turndown from high fire can also be achieved with an intermittent pilot by turning the main fuel off and using the pilot for low fire.

## IGNITION AND FLAME MONITORING

A raw gas pilot with an adjustable orifice pilot cock and an ignition plug are furnished on the Wingcone. This is the recommended method of ignition for both gas and oil operation. Under certain conditions it is possible to direct spark ignite the burner on oil, however, the Engineering Department at Eclipse, Inc. must be contacted if this is planned.

Flame monitoring must be by ultra violet scanner for both gas and oil operation. Flame rod monitoring is not acceptable.

**CAUTION:** It is dangerous to use any fuel burning equipment unless it is equipped with suitable flame sensing device(s) and automatic fuel shut-off valve(s). Eclipse can supply such equipment or information on alternate sources.

## SELECTION

The Wingcone is available in three sizes with maximum capacities up to 5,000,000 Btu/hr.

The proper burner size for an application can be determined using the following formula:  $.24 \times (\text{required temperature rise}) \times .075 \times (\text{total scfm air to be heated}) \times 60 = \text{Btu/hr.}$  Compare this answer to the Btu/hr. ratings shown in the Capacity Chart on page 2. For example: 7000 scfm of air has to be heated from 100° to 400° (300° temperature rise).

$.24 \times 300 \times .075 \times 7000 \times 60 = 2,268,000 \text{ Btu/hr.}$  For this input, the proper choice is the 250 Wingcone which has a maximum capacity of 2,500,000 Btu/hr.

## CAPACITIES

|  | BURNER<br>CAT. NO. | NAT. GAS<br>.65 Sp. Gr. | #2 FUEL OIL<br>140,000 Btu/gal. |
|--|--------------------|-------------------------|---------------------------------|
| Maximum Capacity - Btu/hr. *   | 125 WC             | 1,250,000               | 1,250,000                       |
|  | 250 WC             | 2,500,000               | 2,500,000                       |
|  | 500 WC             | 5,000,000               | 5,000,000                       |
| Maximum Fuel Flow  | 125 WC             | 1250 scfh               | 8.9 gph                         |
|  | 250 WC             | 2500 scfh               | 17.9 gph                        |
|  | 500 WC             | 5000 scfh               | 35.7 gph                        |
| Fuel Pressure Req'd. @<br>Gas Manifold or Oil Nozzle                             | 125 WC             | 3.8" w.c.               | 34 psig                         |
|  | 250 WC             | 2.5" w.c.               | 47 psig                         |
|  | 500 WC             | 3.9" w.c.               | 60 psig                         |
| Required Air Pressure Drop<br>Across Burner ( Δ H) to<br>Achieve Maximum Cap. ** | 125 WC             | .8" w.c. - 1.5" w.c.    |                                 |
|  | 250 WC             |                         |                                 |
|  | 500 WC             |                         |                                 |
| Required Atomizing Air Flow<br>And Pressure To Achieve<br>Maximum Capacity       | 125 WC             | ---                     | 5 scfm/40 psig                  |
|  | 250 WC             | ---                     | 13 scfm/40 psig                 |
|  | 500 WC             | ---                     | 13 scfm/40 psig                 |
| Approximate Visible<br>Flame Length - Ft.  | 125 WC             | 1-1/2 - 2               | 1-1/2 - 2                       |
|  | 250 WC             | 3 - 4                   | 3 - 4                           |
|  | 500 WC             | 4 - 4-1/2               | 3 - 4-1/2                       |

\*Minimum capacity using an interrupted pilot on both gas and oil and modulated atomizing air (oil only) will be 1/20 of maximum.

\*\*Air Flow through the burner at 1" w.c. Δ H across the burner will be 3X the theoretical air flow required for combustion, or 200% excess air.

### TYPICAL APPLICATION BURNER FIRING WITH AIRSTREAM

| BURNER<br>CAT. NO. | A                               | B                       | C                    | C <sub>1</sub>                      |
|--------------------|---------------------------------|-------------------------|----------------------|-------------------------------------|
|                    | RADIATION SHIELD<br>MIN. LENGTH | MIN. DISTANCE<br>TO FAN | MINIMUM<br>DUCT SIZE | MIN. DISTANCE TO<br>DUCT TRANSITION |
| 125 WC             | 2'                              | 4'                      | 2' 6"                | 2' 6"                               |
| 250 WC             | 4'                              | 8'                      | 4'                   | 4'                                  |
| 500 WC             | 4' 6"                           | 9'                      | 4' 6"                | 4' 6"                               |

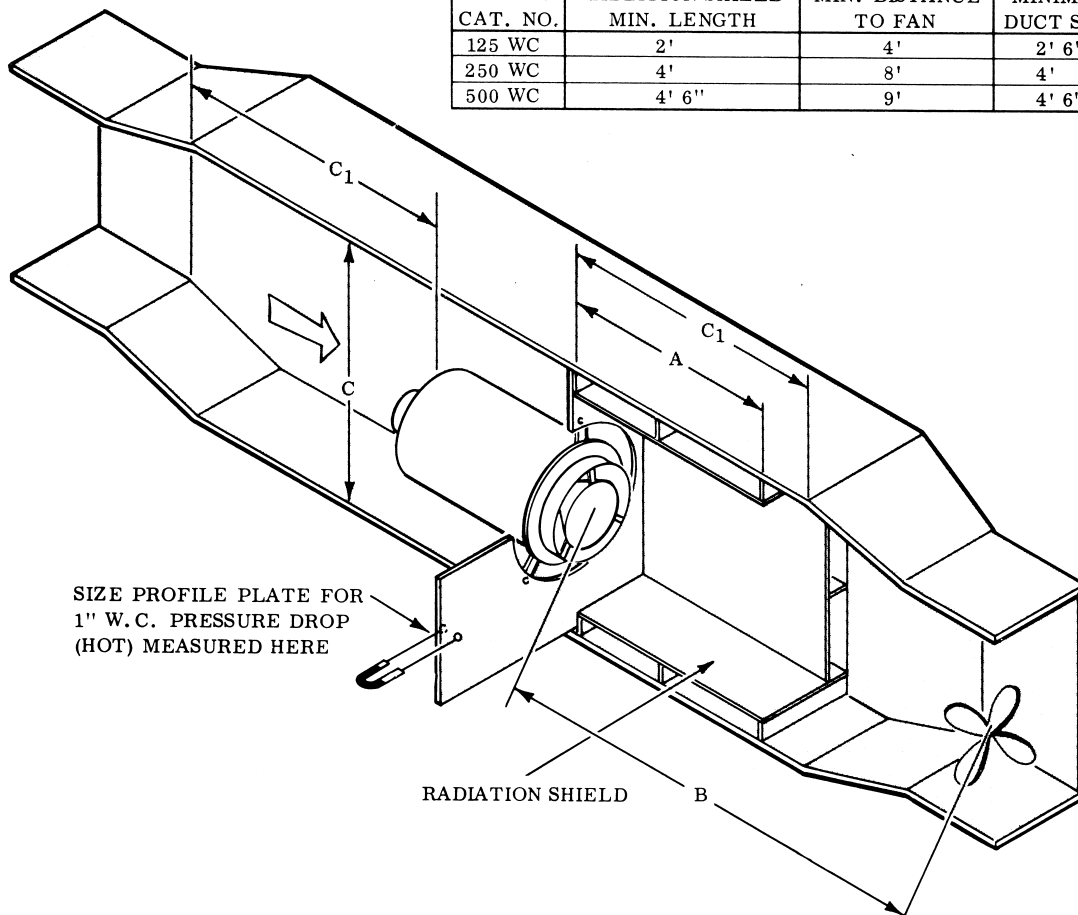

# DIMENSIONS

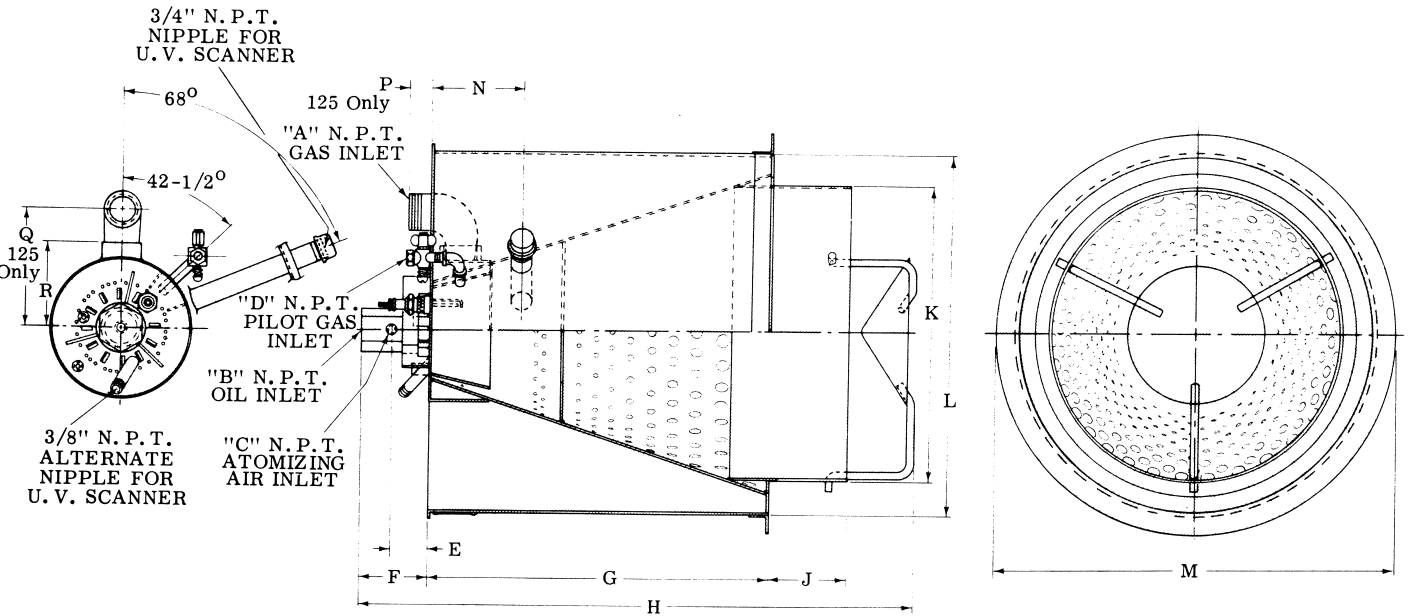

| BURNER CAT. NO. | ASSEMBLY NUMBER | DIMENSIONS (IN INCHES) |     |     |     |         |         |    |          |         |  |
|-----------------|-----------------|------------------------|-----|-----|-----|---------|---------|----|----------|---------|--|
|                 |                 | A                      | B   | C   | D   | E       | F       | G  | H        | J       |  |
| 125 WC          | 100504          | 1-1/4                  | 1/4 | 1/4 | 1/4 | 1-21/32 | 3-3/32  | 15 | 29-31/32 | 7-13/16 |  |
| 250 WC          | 100505          | 1-1/2                  | 1/4 | 1/4 | 1/4 | 1-27/32 | 3-17/32 | 18 | 34-11/32 | 7-15/16 |  |
| 500 WC          | 100506          | 2                      | 1/4 | 1/4 | 1/2 | 1-27/32 | 3-17/32 | 21 | 31-17/32 | 2-11/16 |  |

| BURNER CAT. NO. | ASSEMBLY NUMBER | DIMENSIONS (IN INCHES) |    |         |         |       |       |          |  |
|-----------------|-----------------|------------------------|----|---------|---------|-------|-------|----------|--|
|                 |                 | K                      | L  | M       | N       | P     | Q     | R        |  |
| 125 WC          | 100504          | 11                     | 14 | 16-1/16 | 5-21/32 | 1-1/8 | 5-1/4 | ---      |  |
| 250 WC          | 100505          | 15-5/8                 | 19 | 19-3/4  | 4-7/8   | ---   | ---   | 8-1/6    |  |
| 500 WC          | 100506          | 20-1/2                 | 24 | 26-1/16 | 5-1/2   | ---   | ---   | 10-11/16 |  |

## TYPICAL APPLICATION BURNER FIRING PERPENDICULAR TO AIRSTREAM

| BURNER CAT. NO. | A                           | B                              |
|-----------------|-----------------------------|--------------------------------|
|                 | MIN. BURNER INSERTION DIST. | MIN. DISTANCE TO OPPOSITE WALL |
| 125 WC          | 7-13/16"                    | 30"                            |
| 250 WC          | 7-15/16"                    | 54"                            |
| 500 WC          | 2-11/16"                    | 60"                            |

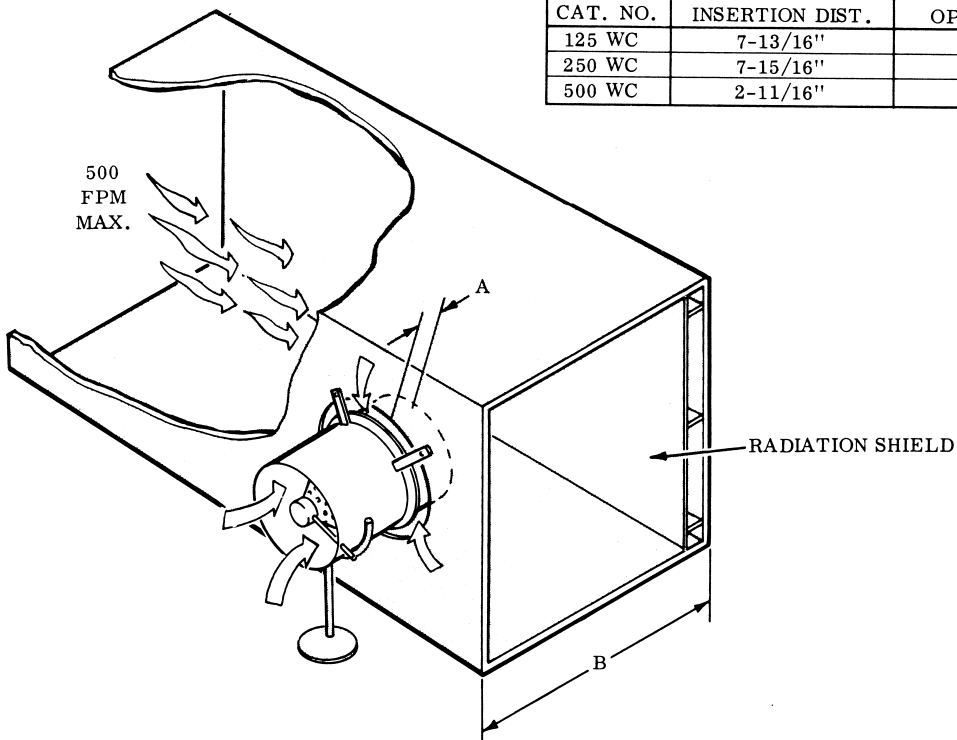

# SUGGESTED FUEL & ATOMIZING AIR PIPING ARRANGEMENTS USING PACKAGED VALVE TRAINS

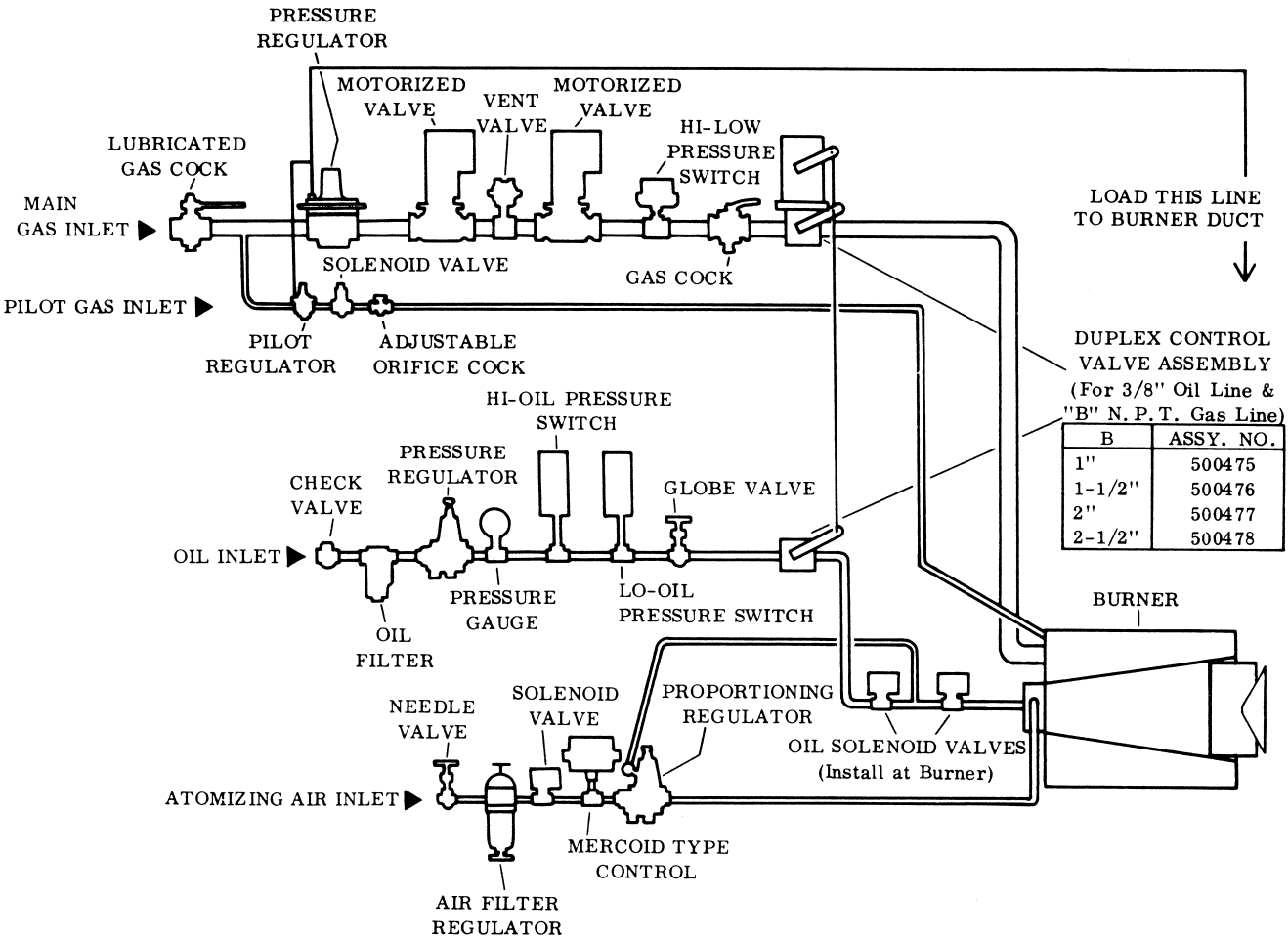

Indicates components supplied in packaged valve train.  
 Indicates additional components and piping which must be customer supplied.

| VALVE TRAIN    | ASSEMBLY NUMBER | N. P. T. INLET | OVERALL LENGTH |
|----------------|-----------------|----------------|----------------|
| MAIN GAS (FM)* | 500093-3        | 1-1/4"         | 29-1/2"        |
|                | 500078-3        | 1-1/2"         | 33-1/4"        |
|                | 500079-3        | 2"             | 35-13/16"      |
|                | 500080-3        | 2-1/2"         | 44-3/8"        |
| MAIN GAS (IRI) | 500090-1        | 1-1/4"         | 41-3/8"        |
|                | 500074-1        | 1-1/2"         | 46-7/8"        |
|                | 500075-1        | 2"             | 49-5/16"       |
|                | 500076-1        | 2-1/2"         | 61-7/8"        |
| PILOT GAS      | 500064          | 1/2"           | 7-13/16"       |
| OIL            | 500081          | 3/8"           | 20-5/16"       |
| ATOMIZING AIR  | 500082          | 1/4"           | 21-1/4"        |

\*Not shown. FM valve train has one manual reset gas valve and no vent valve. Other gas valve train variations are available. (See M-700 Bulletin.)



NU-WAY LIMITED, P.O. Box 1, Vines Lane,  
 Droitwich Worcs, WR9 8NA, England  
 Tel: 01905 794331 / 794242 Fax: 01905 794017  
 e-mail: info@nu-wav.co.uk