

# BRAY

---

## THERMAL SYSTEMS

### INSTRUCTION MANUAL

for

SELECTOS SG COMMERCIAL SERIES  
AUTOMATIC GAS BURNERS.  
TYPES SGO. SG.62. SG.82.

<u>Text.</u>	<u>Page.</u>
1. Foreword.	1.
2. Technical Data.	2.
3. Installation.	4.
4. Commissioning.	7.
5. Service.	9.
6. Fault Finding.	10.
7. General Information.	11.

### DIAGRAMS.

Combustion Heads.	Fig. 1.
UV and Probe Check Data.	Fig. 2.
Gas Control Line Diagram.	Fig. 3.
Wiring Diagram Landis & Gyr LFA/LFB.1.33 On/Off 1 phase.	Fig. 4.
" " Landis & Gyr LFA/LFB.1.33 T.6 On/Off 1 phase.	Fig. 5.
" " Landis & Gyr LFA/LFB.1.33 T.6 On/Off 3 phase.	Fig. 6.
" " Petercem G.236 On/Off 1 phase.	Fig. 7.
" " Petercem G.236 T.6 On/Off 1 phase.	Fig. 8.
" " Petercem G.236 T.6 On/Off 3 phase.	Fig. 9.
" " Satronic TMG.720 On/Off 1 phase.	Fig. 10.
" " Satronic TMG.720 T.6 On/Off 1 phase.	Fig. 11.
" " Satronic TMG.720 T.6 On/Off 3 phase.	Fig. 12.

# SELECTOS

GAS & OIL BURNERS

Education Road · Leeds LS7 2AN · Telephone 0532 435399 · Telex 557431 · Fax 0532 450135

SELECTOS SG SERIES AUTOMATIC GAS BURNERS.FOREWORD.

The Selectos SG Series Gas Burners are suitable for burning all commercial gases, Towns Gas, Natural Gas or L.P.G. and are capable of firing to their rated output with the following inlet gas pressures.

Towns Gas.	3" w.g. (7.5 MBWC)
Natural Gas.	7" w.g. (17.5 MBWC)
L.P.G.	14" w.g.(35.0 MBWC)

(The above pressures are required at Test Point B Fig. 3, with the burner firing).

The burners are fan assisted, nozzle mix type and the operation is fully automatic expanded flame start.

The SG.62 and SG.82 are supplied as standard for 220v/240v. 50Hz. Single Phase with On/Off operation. They can be supplied suitable for use with 380v/440v. 50Hz. Three Phase supply and or with High/Low control as optional extras.

2.  
TECHNICAL DATA.

# GAS

SG0 and SG62							SG82														
Fuel: Natural Gas							Fuel: Natural Gas														
Model	Firing rate		Boiler output @ 80% eff		Gas line size 'BSP'	Motor W hp	Weight kg lb	Model	Firing rate		Boiler output @ 80% eff		Gas line size 'BSP'	Motor W hp	Weight kg lb						
	kW	Btu/h	kW	Btu/h					kW	Btu/h	kW	Btu/h									
SG0	44	150000	35	120000	1/2"	75	15.4	SG82	A	293	1000000	234	800000	1 1/2"	559	51.6					
	73	250000	59	200000		.1	34			410	1400000	328	1120000				114				
SG62 FD	AY	59	200000	47	160000	1"	186			.25	B	410	1400000				328	1120000	2"	.75	59.8
		88	300000	70	240000												586	2000000			
	AZ	88	300000	70	240000																
		105	360000	84	288000																
	176	600000	141	480000																	
	176	600000	141	480000	1 1/2"		34.4														
	293	1000000	234	800000			76														

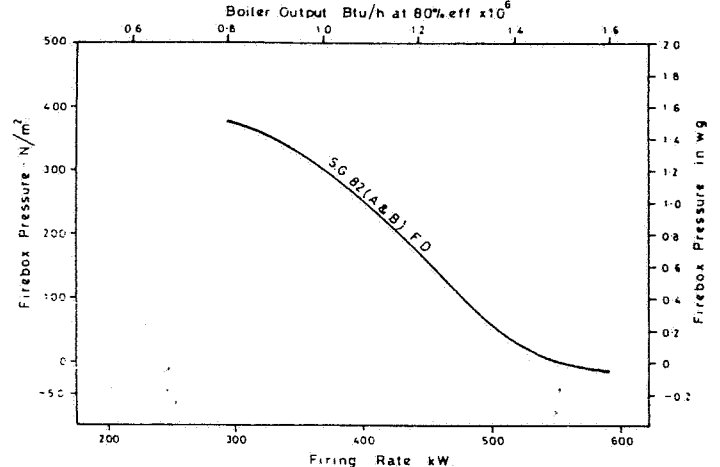
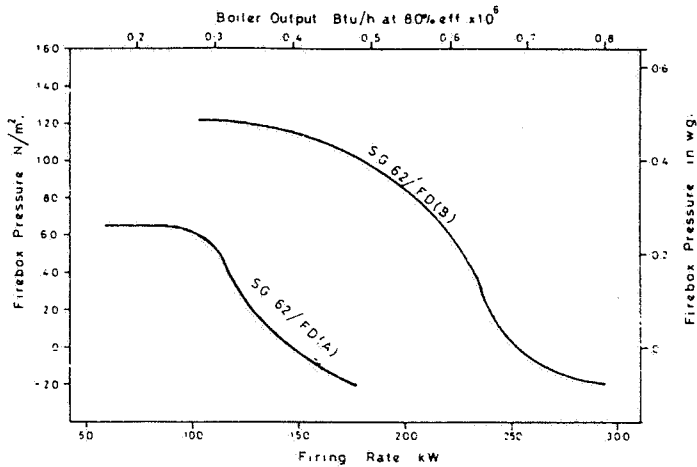

As our policy is one of continuous improvement we reserve the right to amend specifications at any time without prior notice.

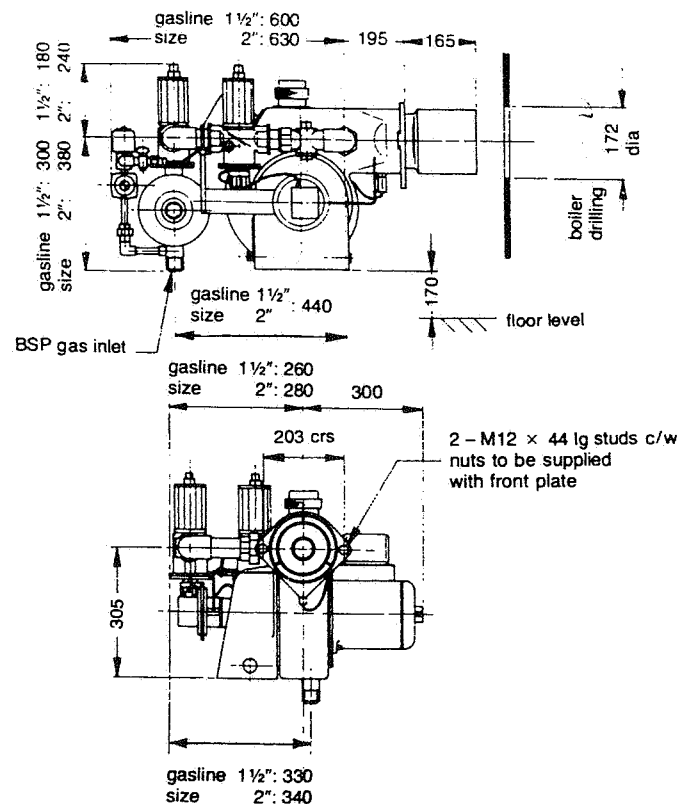
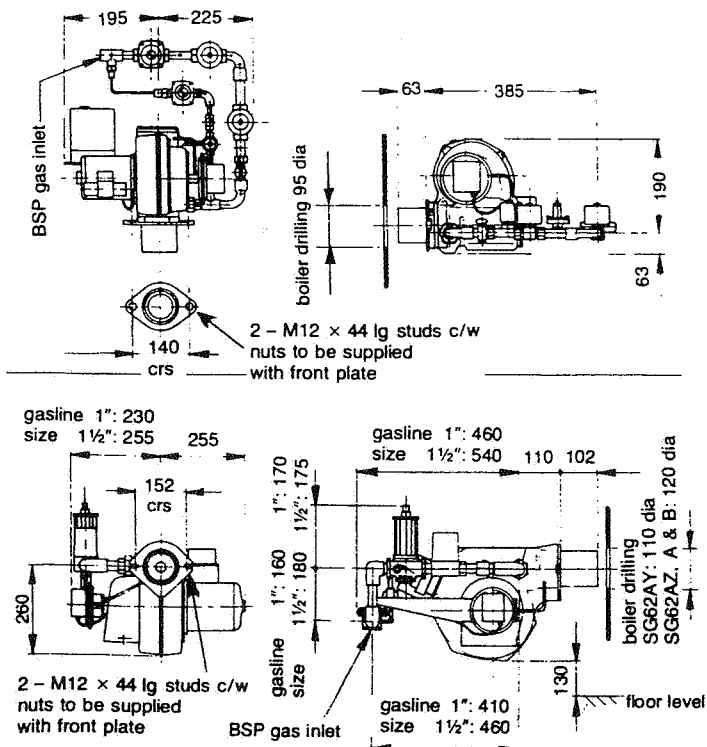

DATA FOR NATURAL GAS		BURNER TYPE :-						
		SG 0	SG 62 FD/AY	SG 62 FD/AZ	SG 62 FD/A	SG 62 FD/B	SG 82 FD/A	SG 82 FD/B
BURNER FIRING RATE	kW	44 73	59 88	88 105	105 176	176 293	293 410	410 586
	Btu h	150 000 250 000	200 000 300 000	300 000 360 000	360 000 600 000	600 000 1 000 000	1 000 000 1 400 000	1 400 000 2 000 000
BOILER OUTPUT AT 80% EFFICIENCY	kW	35 59	47 70	70 84	84 141	141 234	234 328	328 469
	Btu h	120 000 200 000	160 000 240 000	240 000 288 000	288 000 480 000	480 000 800 000	800 000 1 200 000	1 120 000 1 600 000
MAIN GAS LINE	"B.S.P.	1/2	1	1	1	1 1/2	1 1/2	2
PILOT GAS LINE	"B.S.P.	3/8	3/8	3/8	3/8	3/8	3/8	1/2
ELECTRIC MOTOR	W hp	75 1/10	186 1/4	186 1/4	186 1/4	186 1/4	559 3/4	559 3/4
FAN DIAMETER	mm	108	146	146	160	180	225	225
DRAUGHT-TUBE DIA.	I.D. mm	73	96	109	109	109	138	152
NOZZLE SIZE	Nº HOLES x SIZE mm	/	8 x 3.0	8 x 3.5	8 x 4.0 8 x 4.5	8 x 5.2 8 x 5.9	8 x 7.1	8 x 8.7
IGN. TRANSFORMER		PARMEKO P72600 OR DANFOSS 52L						
ELECTRICAL SUPPLY	STANDARD	220/240 V 50 Hz SINGLE PHASE A.C.						
STARTING CURRENT	AMPS	7.5	16.6	16.6	16.6	16.6	21	21
RUNNING CURRENT	AMPS	0.7	1.67	1.67	1.67	1.67	4.8	4.8
ELECTRICAL SUPPLY	OPTIONAL EXTRA	/	380/440 V 50 Hz THREE PHASE A.C.					
STARTING CURRENT	AMPS	/	2.5	2.5	2.5	2.5	7.0	7.0
RUNNING CURRENT	AMPS	/	0.41	0.41	0.41	0.41	1.15	1.15
CONTROL BOX	STANDARD	PETERCEM GE 236 WITH IONISATION PROBE						
CONTROL BOX	OPTIONAL EXTRA	LANDIS & GYR LFA 1.33 WITH IONISATION PROBE						
CONTROL BOX	OPTIONAL EXTRA	/	LANDIS & GYR LFB 1.33 WITH UV. DETECTOR QRA2					

ALL SELECTOS GAS BURNERS ARE DESIGNED AND SUPPLIED TO MEET THE LATEST GAS STANDARDS

#### MANUFACTURED GAS :-

The SG0 burner with a 1" gas line is for use with manufactured gas for appliances having a maximum rated output of 51 kW (175000 Btu/h). The SG62 burner with a 2" gas line is for manufactured gas for appliances having a maximum rated output of 200 kW (680000 Btu/h). All dimensions will be subject to alteration.

The SG82 burner with a 2 1/2" gas line is for use with manufactured gas for appliances having a maximum rated output of 470 kW (1600000 Btu/h). Dimensions will be subject to alteration.

### 3. INSTALLATION.

The burner(s) comply with the relevant standard gas regulations and it is recommended that the installation of which it is part is carried out by registered and qualified engineers.

#### 3.1. Pre-installation check.

Examine the burner for possible damage during transit and check that the burner is supplied for the correct electricity and gas supply available.

##### 3.1.1. Nozzle size.

Check that the size of the nozzle is correct for the appliance by reference to the diameter shown on Page 3.

##### 3.1.2. Draught tube.

Check that the correct draught tube diameter and identification letters on the burner nameplate are correct for the nozzle size as shown on Page 3.

#### 3.2. Burner mounting.

The burner should be securely mounted on the appliance by means of its fixing flange and two M12 x 44 mm. long studs. A gasket is provided to minimise the transmission of heat and vibration.

#### 3.3. Combustion chamber.

##### 3.3.1. C.I. Sectional boilers.

To give sufficient protection to the boiler house floor, and at the same time to keep the firing height to a minimum, we recommend that the normal 114 mm. (4½") boiler base is left hollow. This enables the finished firing floor level consisting of 73 mm. (3") of insulating bricks and 76 mm. (3") of refractory material to be only 38 mm. (1½") above this base.

The height of the side walls should adequately protect the boiler nipples, and if the boiler has extended skirts then these should be protected with insulating bricks in addition to the main refractory lining.

##### 3.3.2. Wet based boilers.

No special refractory lining is required except for the rear wall which should be 40/42% alumina firebrick or similar refractory material.

The end of the draught tube should project about 6 mm. (¼") into the combustion chamber and if the front wall of the latter is not water cooled it should be of a suitable high temperature insulating material.

3.4. Gas supply connection.

The incoming gas line should be checked for position and level before fastening the flange bolts to prevent tension on the burner body.

All pipework and fittings must be gas tight. It is recommended that a fire valve should be installed.

The gas supply line should terminate with a quick acting gas shut-off valve.

3.5. Electrical connection.

At least the last ½m (18") of the mains supply to the burner, and also the connection to a boiler thermostat, should be run in a flexible conduit.

The connections should be in accordance with the wiring diagram depending on the type of control and electric supply available.

All wiring should conform to I.E.E. regulations and an isolating switch should be fitted adjacent to the appliance, the supply being protected by 15 amp fuses.

3.6. Controls.

The flame failure controls fitted on the Selectos Gas Burners are either Petercem GE.236A1 with Ionisation Probe or Landis & Gyr LFB.1.33 with UV Detector QRA2, or Landis & Gyr LFA1.33 with Ionisation Probe.

When connecting the burner electrically the wiring should be in accordance with the appropriate wiring diagram as shown on front cover.

Control operating sequence.

Petercem GE.236A1 Control.

Pre-purge time.	60 seconds.
Pre-ignition time.	6 seconds.
Post ignition time.	3 seconds.
Start gas proving time.	9 seconds.

With the start gas proved and detected by the Ionisation Probe, the main gas valves will open 78 seconds from the start of sequence.

Control operating sequence.

Landis & Gyr LFB.1.33 and LFA.1.33 Control.

Pre-purge time.	30 seconds.
Safety time for Pilot flame. (electric ignition)	3 seconds.
Pre-ignition time.	3 seconds.
Pilot proving time.	12 seconds.

6.

With the pilot flame proved and detected by the UV cell, or Ionisation Probe, the main automatic gas valve will open in 48 seconds from the start of sequence (Green light on).

(Reaction time to loss of flame (Lockout 1 second)).

(Reaction time to detected pilot flame 1 second).

The Lockout reset device is incorporated with the lockout light, and is located in the front of the control box.

3.7. Ventilation.

To ensure an adequate supply of air for combustion the room in which the burner is installed should have some permanent ventilation in the order of 5.5 sq. cm. per kW (1 sq. inch. per 4000 Btu/h).

4. COMMISSIONING.

It is recommended that burners should be put into operation by a competent engineer, and that recognised combustion testing instruments should be used to enable the burner to be adjusted to the correct operating conditions. The normal procedure is as follows, the number references relate to Fig. 3.

4.1. Check electrical connections.

4.1.1. Check that electrical connections are in accordance with the appropriate wiring diagram.

Check correct operation of flame failure control.

4.1.2. Close main valve A Fig. 3. and switch on electric supply and check that burner runs through to lock out condition.

4.1.3. Check correct rotation of electric motor.

4.2. Gas Test.

A check should be carried out to ensure that the automatic gas valves fitted on the main line D & F and the pilot line K & (M if second pilot valve is fitted) are seating correctly.

Proceed as follows:

Remove screw from Test Plug B and connect a manometer (U Tube) capable of registering at least 12" w.g.

Remove the cap from the top of the main governor and turn internal adjusting screw down to give maximum pressure.

Ensure that the gas supply is turned on at the meter.

Close main gas manual valve H.

Close Pilot gas valve P.

Open main gas valve A for two seconds only.

Close the main gas valve A and the pressure shown on the manometer should remain constant.

Check main gas valves by connecting open end of manometer to test plug E.

Open main valve A and check that 'U tube' shows no increase in pressure.

Close main valve A and change manometer tube from plug E and connect to plug G.

Open main valve A and check that 'U tube' shows no increase.

Close main valve A.

Check pilot line by similar procedure using test plugs J, L & N.



8.

Re-adjust the main governor adjusting screw to approximately  $\frac{1}{2}$ " from the top.

Open Main gas valve A.

Set air damper approximately half open.

Remove cover plate from air pressure switch and set to minimum pressure by rotating adjusting screw or dial in negative direction.

4.3. Firing the Burner.

Ensure that all manually operated gas valves are open.

Vent all remaining air from the gas pipework via Test plug B.

Vent pilot line via Test plug J.

When all the air has been removed from the gas line connect manometer to Test plug Q to check gas pressure available at nozzle.

Set thermostats to required temperature.

Switch on electric supply (Amber light on).

The burner will then start on pre-purge.

4.4. Setting the Pilot.

When the pilot solenoid opens, adjust the gas pressure via the pilot Governor to ensure that this rate does not exceed 10% of the main flame firing rate.

4.5. Setting the Main Flame.

With the main flame established set the gas rate via the main governor to the C.F.M. required.

Adjust the air damper to give correct  $\text{CO}_2$  ( 9 - 11% ).

Check that there is no carbon monoxide (CO) present in the flue gases.

(If CO is detected in the flue gases, open the air damper or decrease the gas rate until it is eliminated).

With the air damper and gas rate adjusted correctly set the Pressure Switch by turning its adjusting screw or dial so as to increase the reading on the air pressure scale until the gas valve closes. Note the scale reading in mbar and then re-adjust to about one third of that scale reading and the burner should re-cycle.

## 5. SERVICING.

To maintain optimum performance and to avoid possible breakdowns the burner should be serviced regularly by a qualified engineer. The frequency of attention required may vary widely depending on conditions of use and the following recommendations are given as a guide.

- 5.1. Very little service attention is required except for checking the automatic valves for gas tightness.

Clean UV cell with a soft clean cloth at least once per month.

Check flame failure control operation at least once a month.

Check UV cell or Ionisation Probe for measurement of detector current at least once every six months (see Fig. 2.)

Cleaning any dust off the fan and combustion head, checking the air pressure switch and lubricating the motor with 2 - 3 drops of good quality oil twice a year.

The intervals between service depends on the frequency of use but it is recommended that the burners are checked at least twice a year.

For safety reasons the UV cell should be replaced after 10,000 operational hours.

6. FAULT FINDING.1. Motor does not start.

- (a) Press Lockout reset button (red light on).
- (b) Thermostat or controller not calling for heat.
- (c) Check current supply and fuse (amber light off).

2. Motor starts, burner not igniting (Red flame failure light).

- (a) Check pilot solenoid valve; if operating check ignition spark. Remove pilot unit and check spark electrode for spark gap or short circuit. On boilers fitted with an explosion door, pilot flame and spark can be checked with flame mirror.
- (b) Incorrect position of UV cell or Ionisation Probe - re-position.
- (c) Check main valve operation. If in open position (check through window on valve cover), shut down burner immediately, insufficient gas supply.

3. Motor starts, Burner not igniting, control box re-cycles (No flame failure light).

- (a) Check air pressure switch.

4. Burner flame unstable.

- (a) Check rotation of burner fan.
  - (b) Check damper position.
  - (c) Check for excess gas.
-

**GENERAL INFORMATION**  
TYPICAL PROPERTIES OF GASEOUS FUELS

	NATURAL GAS	MANUFACTURED GAS	PROPANE	
CALORIFIC VALUE (gross)				
	Btu/ft <sup>3</sup> (MJ/m <sup>3</sup> )	1025 (38.2)	500 (18.7)	2500 (93)
SPECIFIC GRAVITY	0.6	0.5	1.52	
COMBUSTION AIR REQ'D				
	Vol/Vol	9.84	4.5	23.8
	ft <sup>3</sup> /1000 Btu m <sup>3</sup> /MJ	9.6 (0.26)	9.0 (0.24)	9.5 (0.25)
APPROX. INFLAMMABILITY LIMITS % GAS IN AIR	5 TO 15	4 TO 40	2.4 TO 9.5	

**RELATIONSHIP BETWEEN CO<sub>2</sub> & EXCESS AIR**

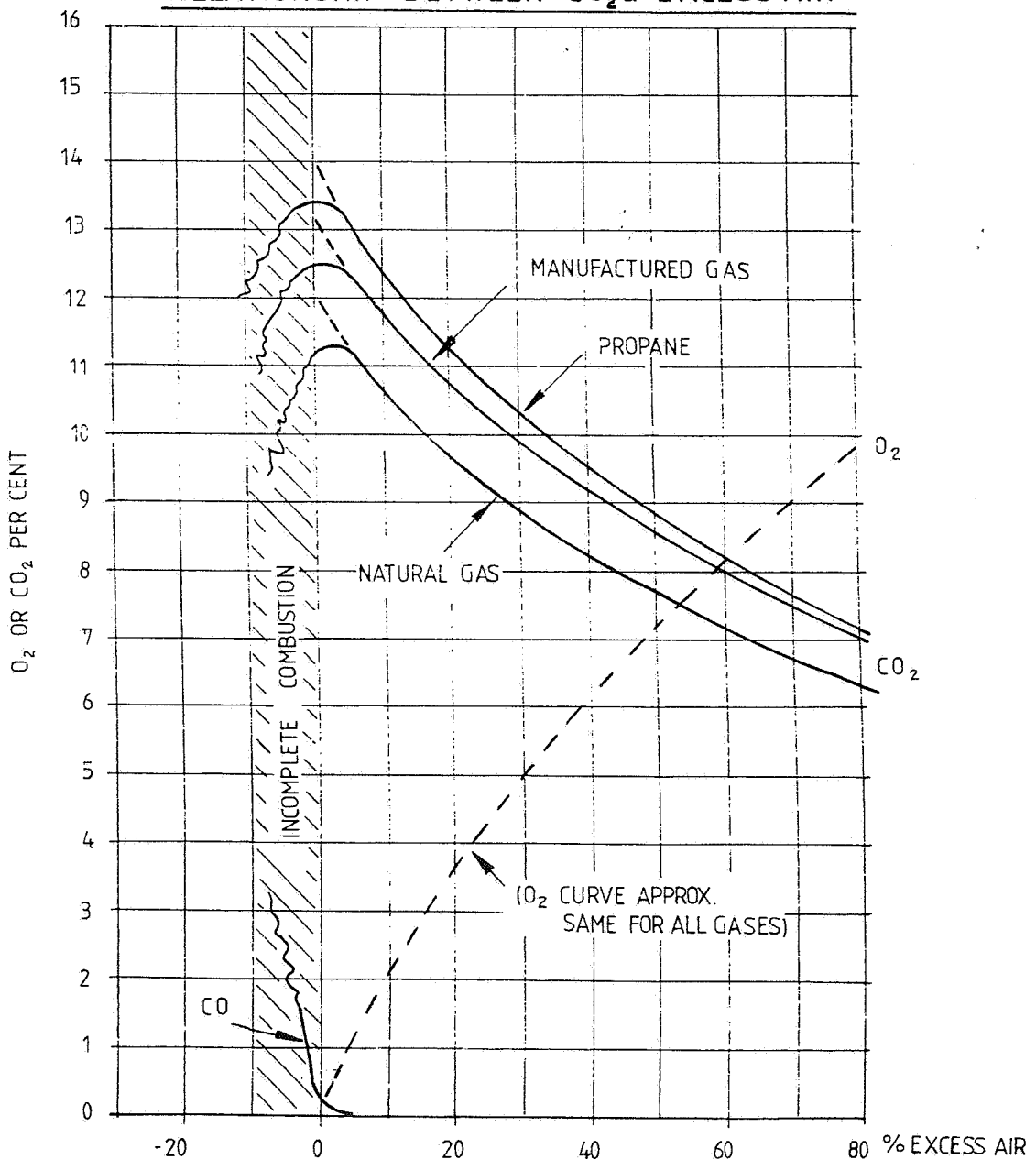

COMBUSTION HEADS

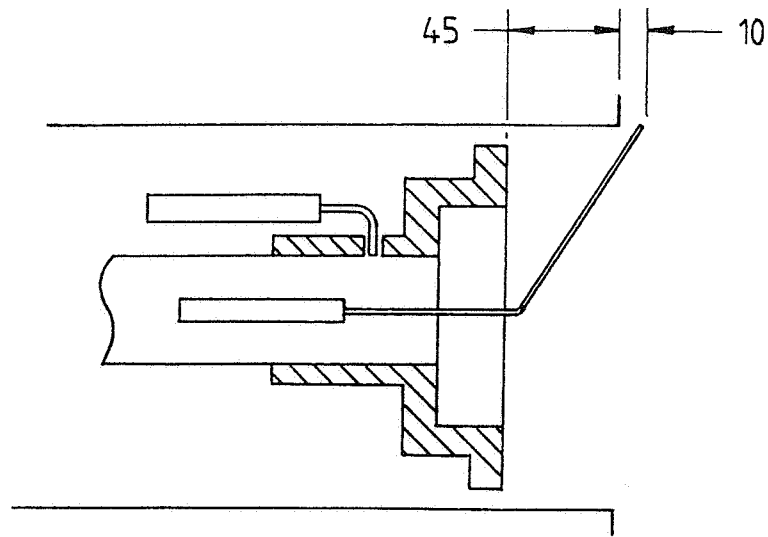

S.G.0

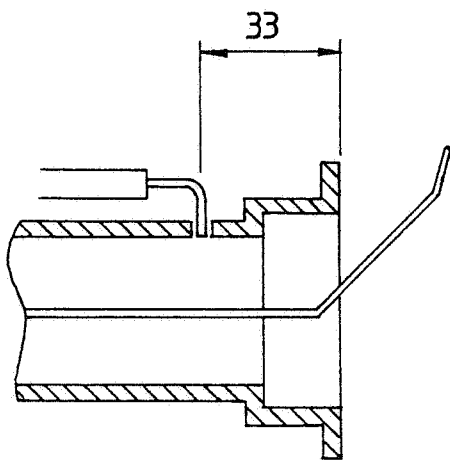

SG 62 CN (WITH PROBE)

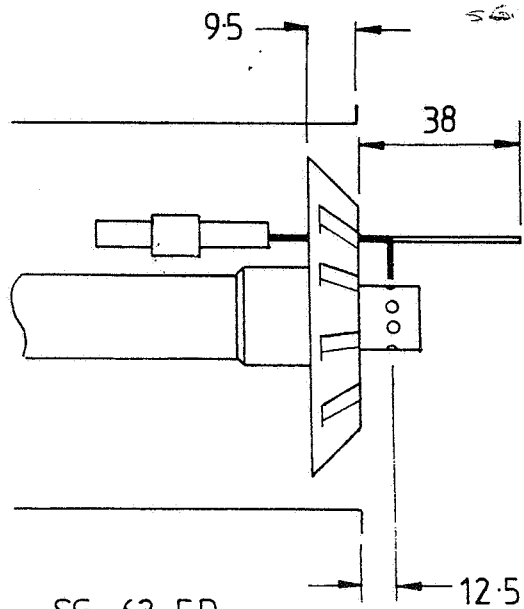

SG 62 FD

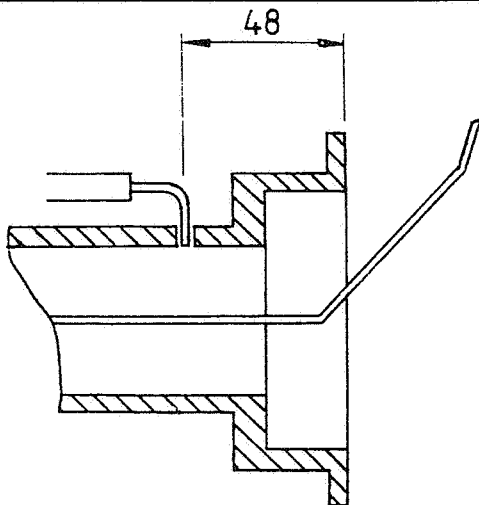

SG 82 CN (WITH PROBE)

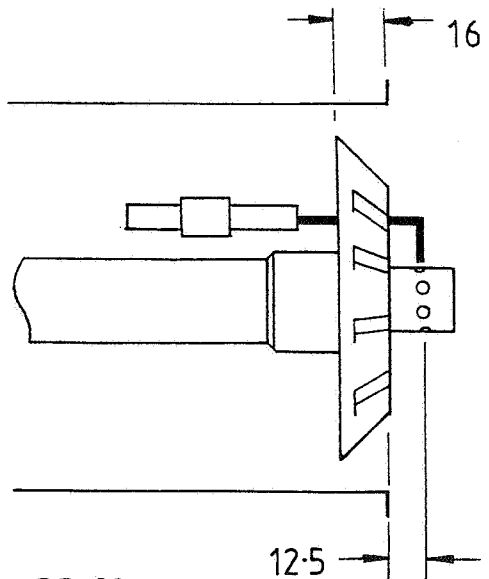

SG 82 FD

FIG.1

## U.V. & PROBE CHECK

CONTROL BOX	TYPE	MINIMUM CURRENT	NORMAL RUNNING	TERMINAL N <sup>o</sup> 'S	
				A	B
LANDIS & GYR LFA	PROBE	7 $\mu$ A	12 - 50 $\mu$ A	13	14
LANDIS & GYR LFB	U.V.	100 $\mu$ A	200 - 300 $\mu$ A	13	14
PETERCEM GE 236	PROBE	10 $\mu$ A	30 - 100 $\mu$ A	7	8
SATRONIC TMG	U.V.	2 $\mu$ A	15 $\mu$ A	EARTH	1

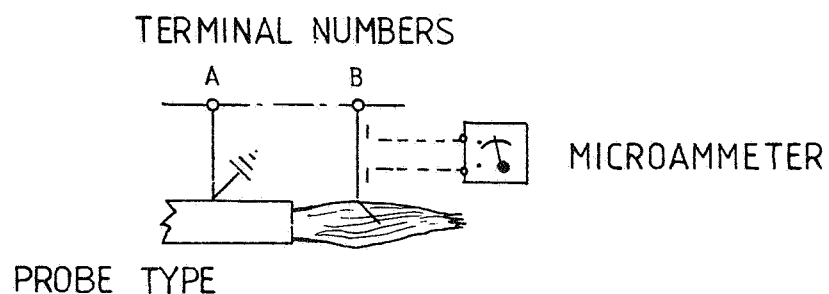
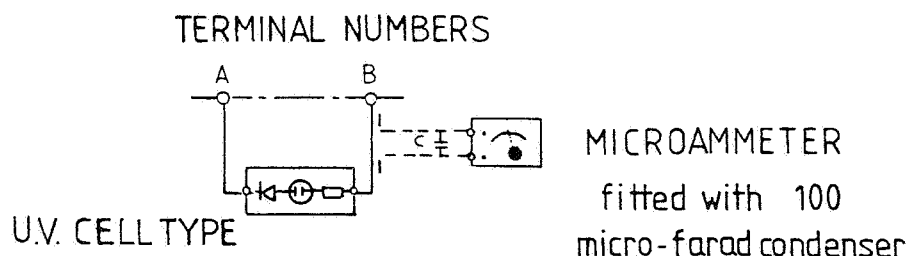
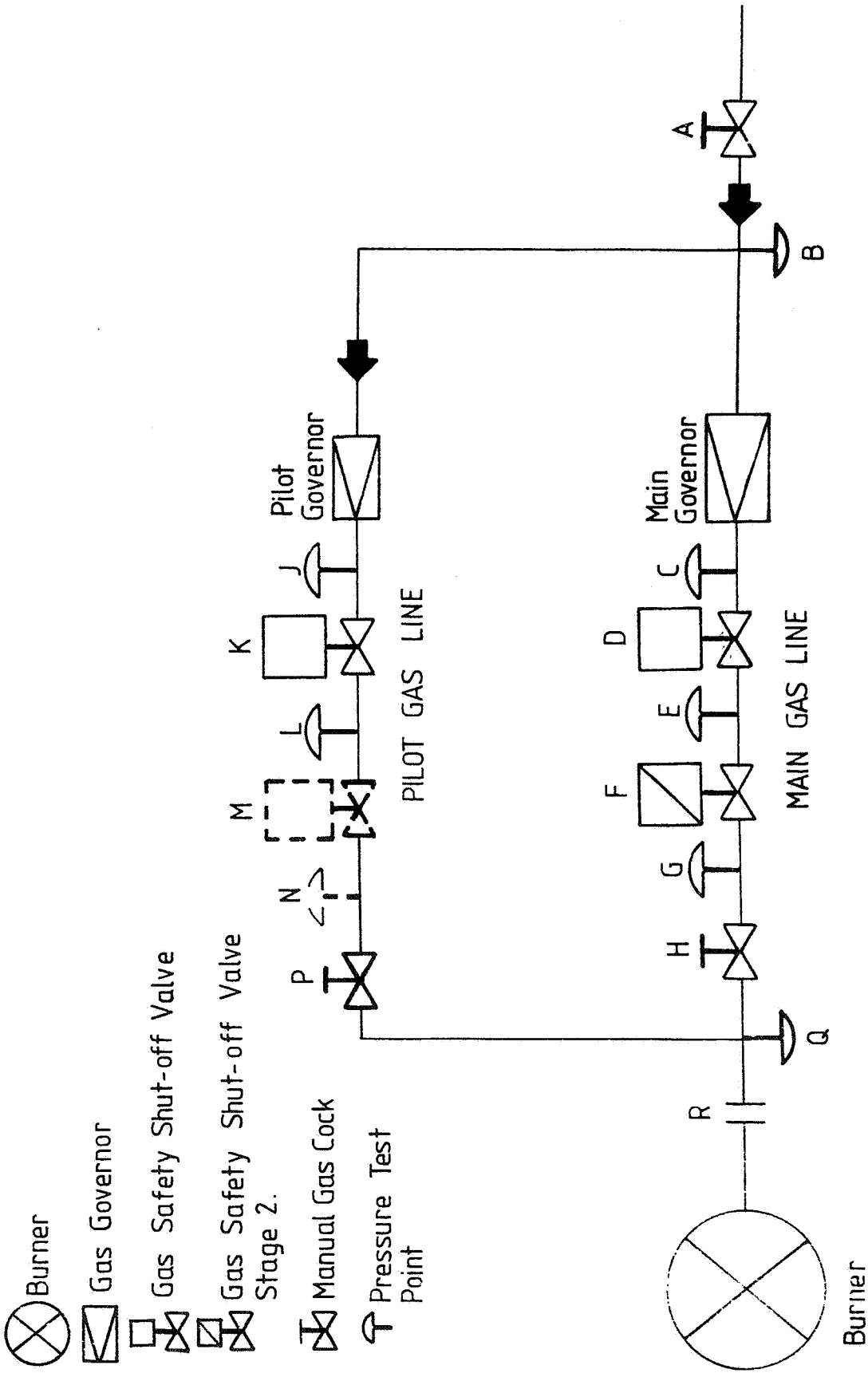
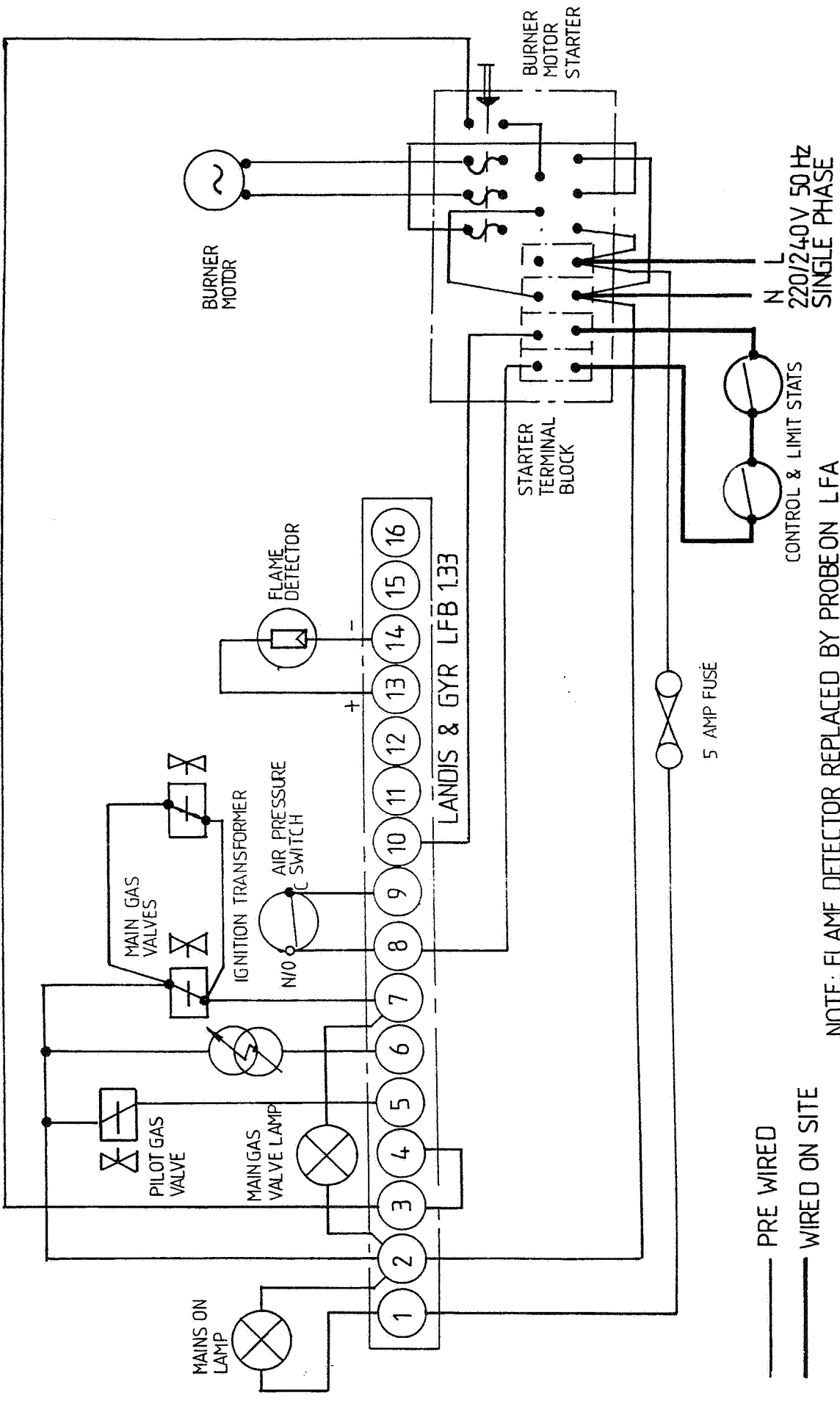

FIG. 2



ISOLATING VALVE (A) NOT SUPPLIED

FIG. 3



NOTE: FLAME DETECTOR REPLACED BY PROBE ON LFA

FIG 5

LANDIS & GYR LFA/LFB 1,33 T6 ON-OFF SINGLE PHASE



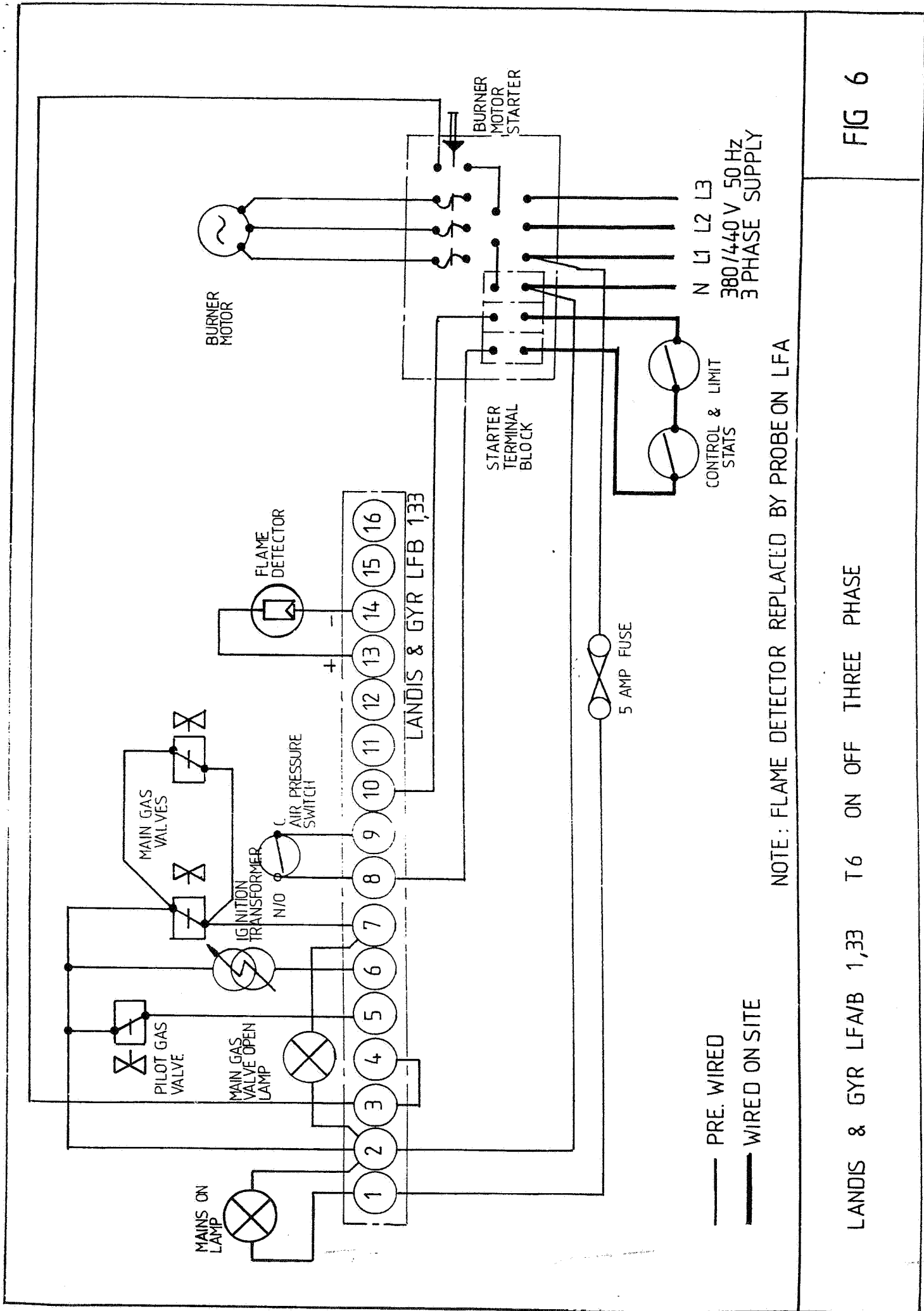
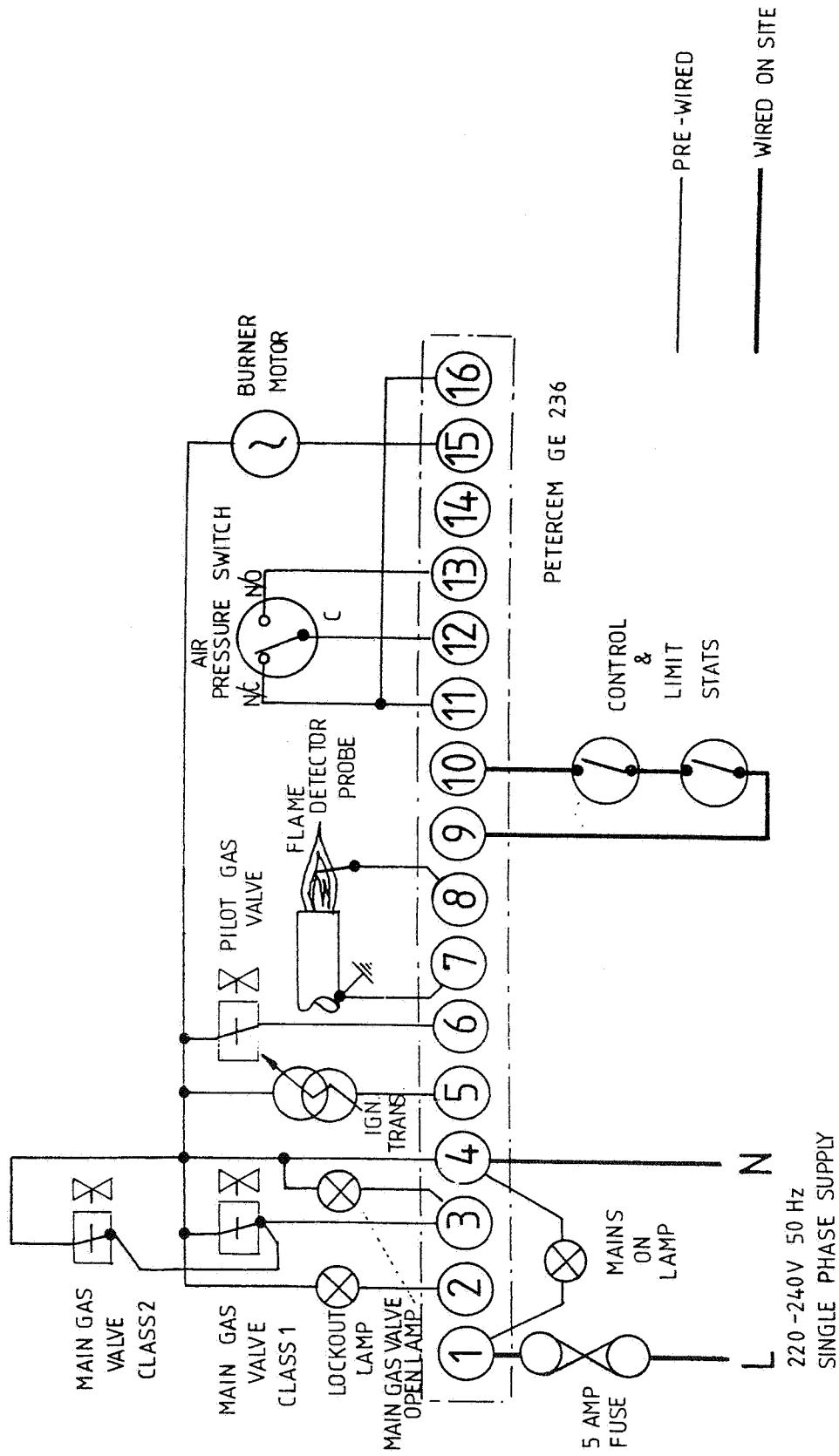

FIG 6

LANDIS & GYR LFA/B 1,33 T 6 ON OFF THREE PHASE



PETERCEM GE 236 CONTROL BOX ON-OFF SINGLE PHASE

FIG.7

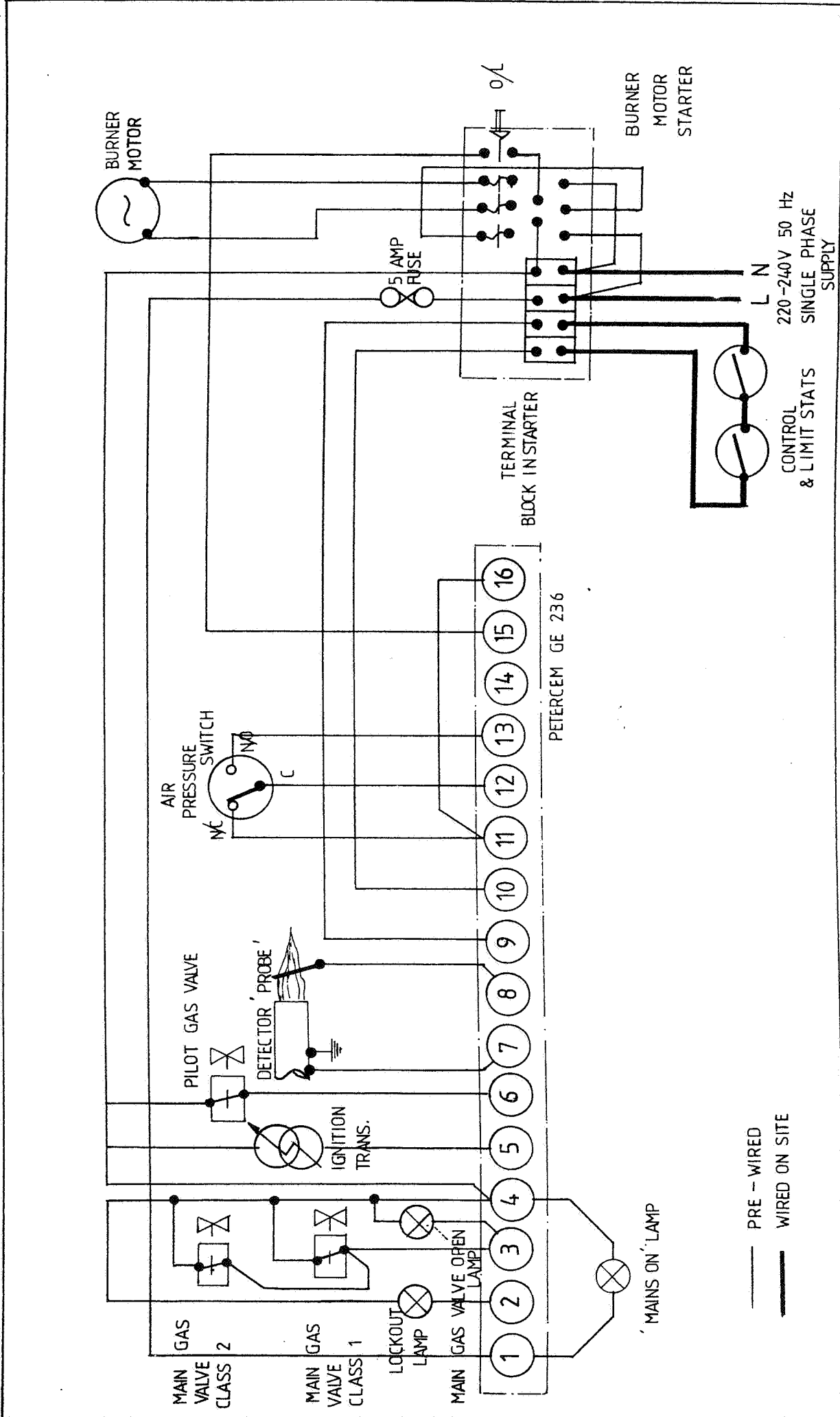

PETERCEM GE 236 T6 ON-OFF SINGLE PHASE

FIG.8

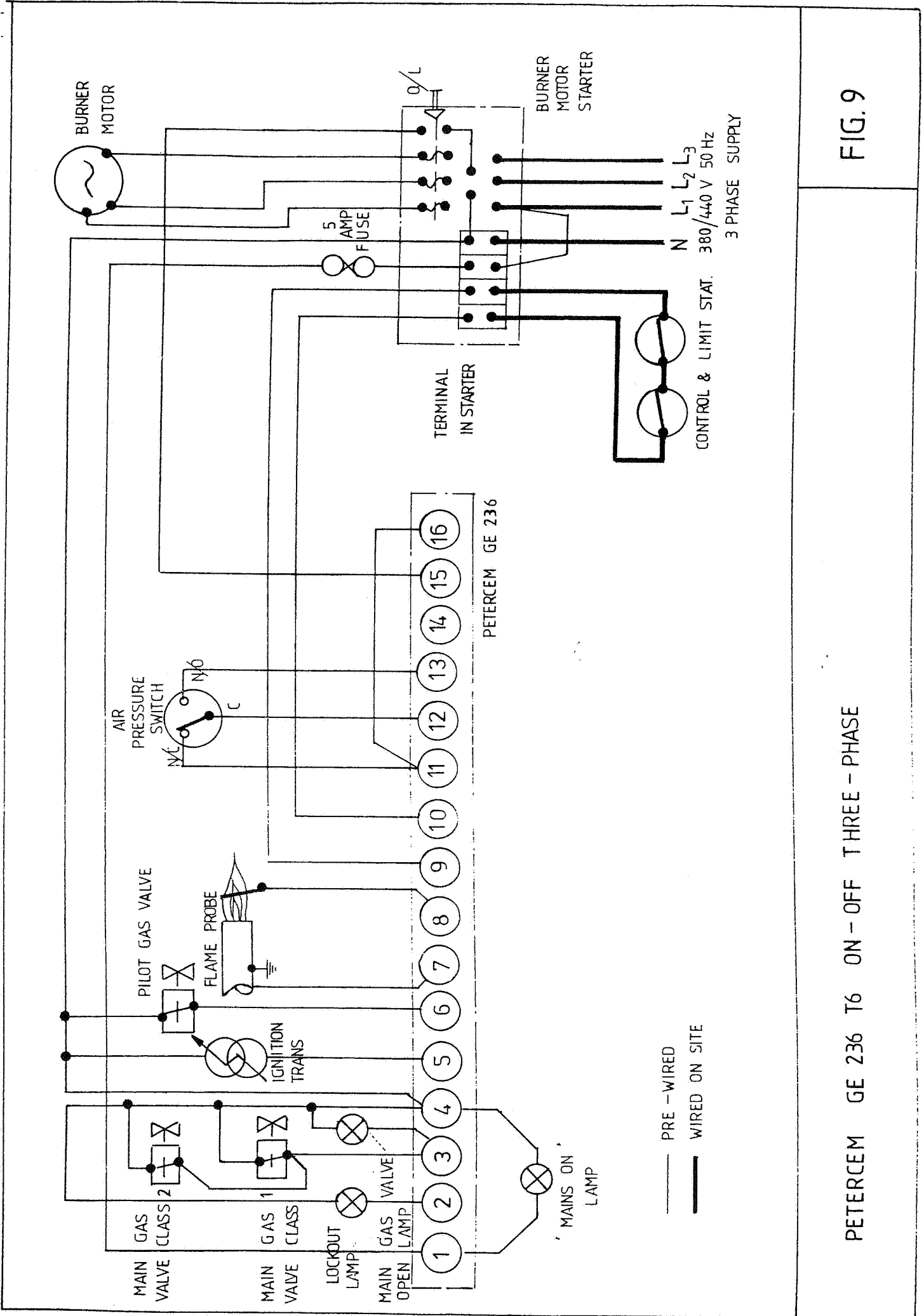

PETERCEM GE 236 T6 ON - OFF THREE - PHASE

FIG. 9

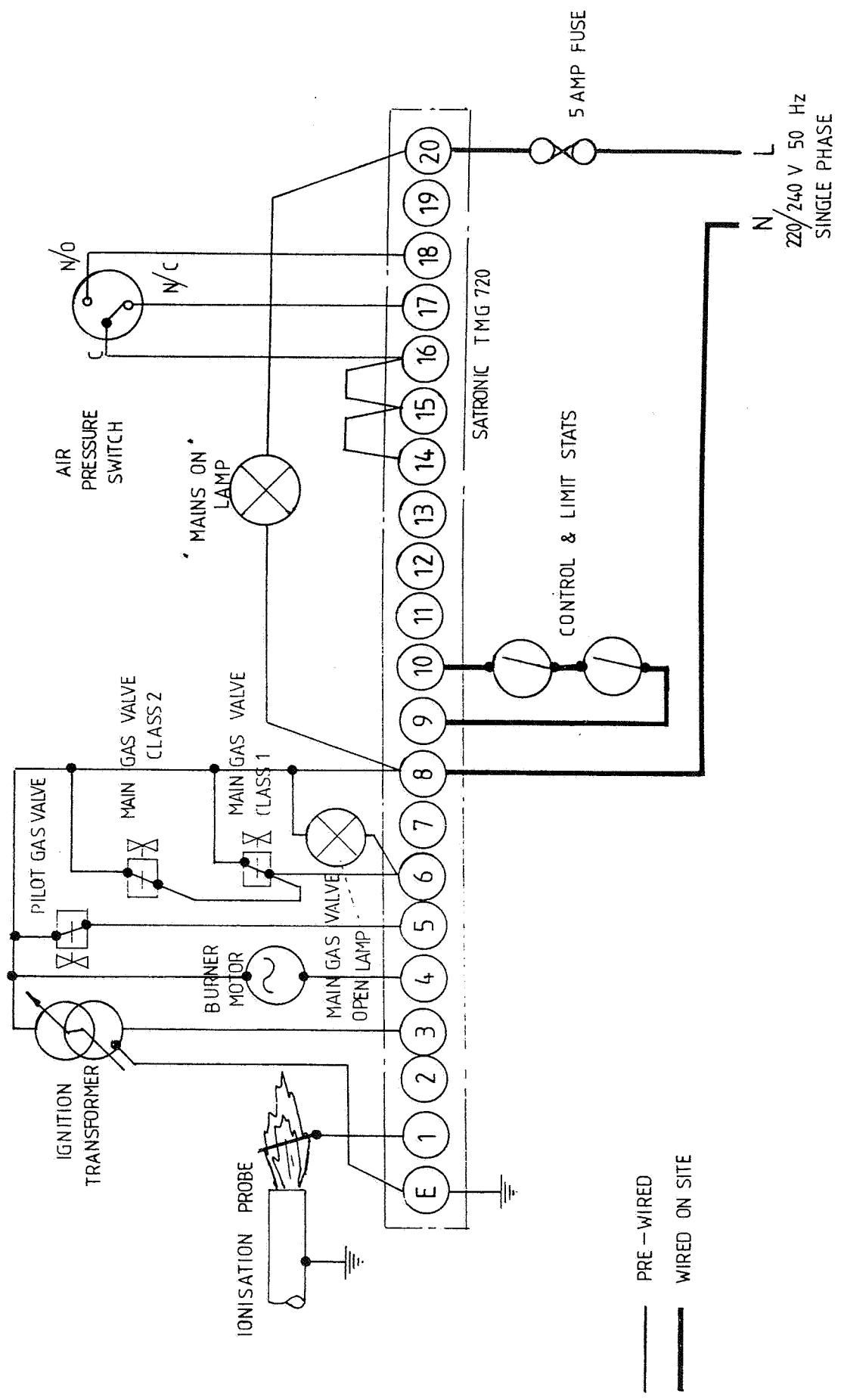

SATRONIC TMG 720 ON-OFF SINGLE PHASE

FIG.10

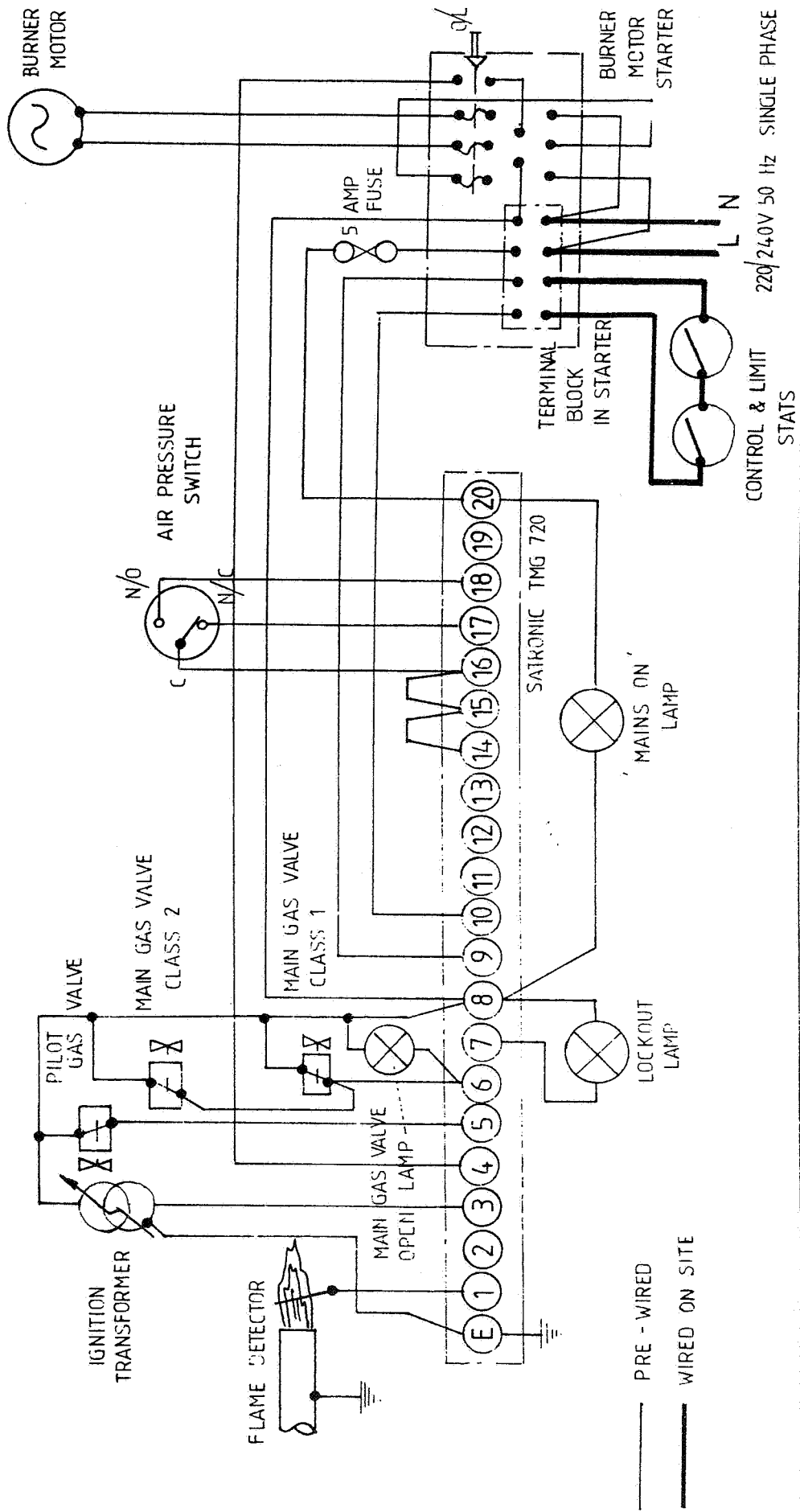

SATRONIC TMG 720 TS ON-OFF SINGLE PHASE

FIG.11