

Handbook

Series D Fully Automatic Oil Burners Models D 18A, D 18B & D 18C

BURNER CAPACITY

D18A

144kW to 380kW

490,000 Btu/h to 1,300,000 Btu/h

D18B

300kW to 470kW

1,000,000 Btu/h to 1,600,000 Btu/h

D18C

300kW to 585kW

1,000,000 Btu/h to 2,000,000 Btu/h

THE SELECTOS RANGE

The Selectos D18 range of fully automatic oil burners are designed to meet the requirements of BS 799.

The range is suitable for modern boilers, air heaters and process applications.

CONSTRUCTION

A monobloc metric design, the burner is suitable for flange mounting to the boiler/air heater frontplate.

AIR REGULATION

Air for combustion can be adjusted to give maximum efficiency.

CONTROLS

Flame supervision by miniature photo electric cell with sequence controller.

The burner operation may be controlled by thermostats, time switches etc.

OPERATION

Two Stage (High/Low) or Low Flame Start (L.F.S.) operation.

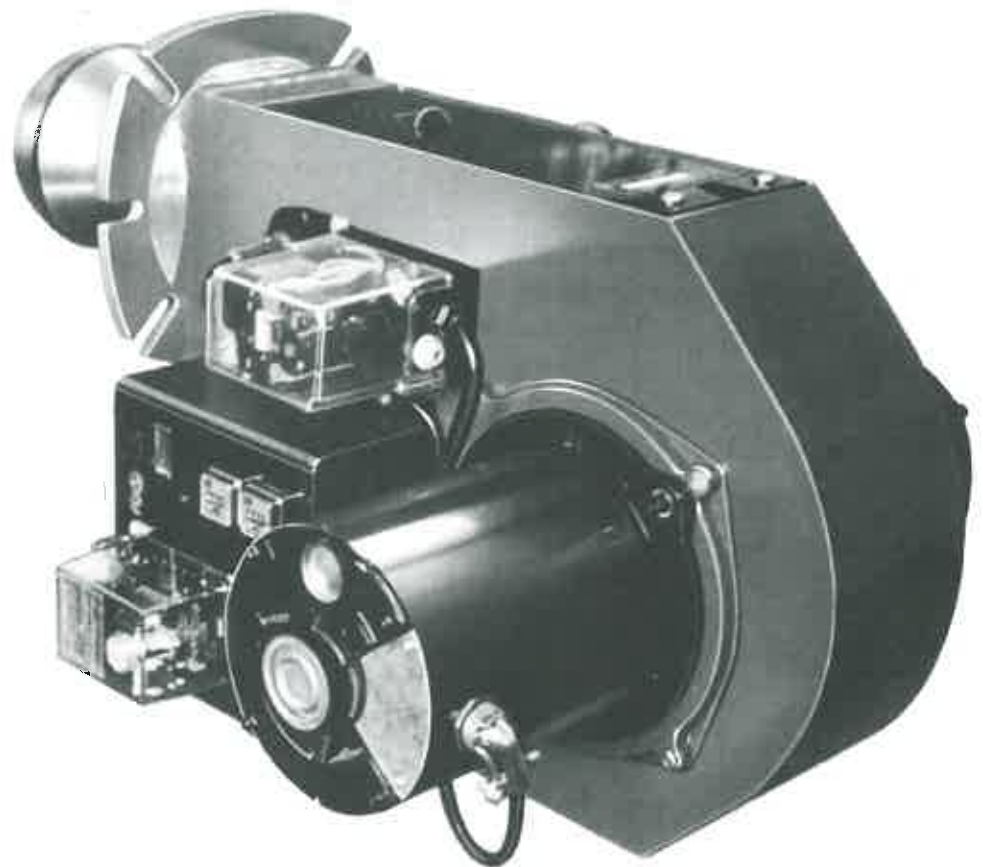

FUEL SYSTEM

Pump fitted with solenoid cut-off valve, suitable for single pipe gravity feed or two pipe suction lift systems. It is recommended that an in-line fuel filter should always be fitted.

FUEL

Class D (1.5 - 5.5cSt @ 40°C) Light Gas Oil.

OPTIONAL EXTRAS

Fully closing air damper (F.C.A.D.)

INTRODUCTION

The D18 is a fully automatic oil burner, designed to meet the requirements of BS 799, and is suitable for modern boilers, air heaters and process applications.

The burner should be installed and commissioned in accordance with these instructions by an experienced qualified engineer.

These instructions cover standard burner and general applications. Where the burner is supplied as part of a matched tested unit, the manufacturers recommendation regarding any specific combustion head settings etc. should be followed.

The burner is supplied complete with pre-wired controls. Electrical connections to the burner should be carried out in accordance with the wiring diagram supplied with the burner.

TECHNICAL DATA

Capacity			
D18A	min	144kW	490,000 Btu/h
	max	380kW	1,300,000 Btu/h
D18B	min	300kW	1,000,000 Btu/h
	max	470kW	1,600,000 Btu/h
D18C	min	300kW	1,000,000 Btu/h
	max	585kW	2,000,000 Btu/h

Fuel

Class D (1.5 - 5.5cSt @ 40°C) Light Gas Oil.

Electrical Data

240V 1ph 50Hz or 415V 3ph 50Hz.

D18A motor 370W

D18B & D18C motor 550W

Start Current (A)	1ph	3ph
D18A	28	10
D18B & D18C	26	15

Run Current (A)	1ph	3ph
D18A	5	5
D18B & D18C	6	5

Ambient Temperature

Maximum 60°C

INSTALLATION

Pre-Installation Check

Check that the operating combustion chamber pressure is within the range for the burner, and that the combustion head settings and nozzle are correct for the appliance to be fired (Fig.1).

Burner Mounting

The burner should be securely mounted by means of the fixing flange, and gasket provided. The mounting flange and boiler drilling details are shown on the back cover of this handbook.

Fuel Supply

The oil supply from the storage tank to the burner should be run in copper, steel or aluminium pipe. Galvanised pipes and fittings **should not** be used. All pipework and fittings must be oil tight and screwed joints should be made good with an oil resistant compound.

The supply should terminate close to the burner with a valve and filter, and the last 1/3 metre should be run in flexible oil pipe to facilitate removal of the burner during service and maintenance.

The size and arrangement of the pipework will depend on the distance and height of the storage tank in relation to the oil pump inlet on the burner. Where the delivery connection on the tank is above the level of the oil pump inlet, a "Single Pipe System" (Fig 3) may be used. Where the delivery connection on the tank is below the level of the oil pump inlet, a "Two Pipe System" (Fig 4) must be used.

Electrical Supply

An isolating switch should be fitted as close as possible to the appliance and the supply protected by a fuse as specified in the Technical Data section.

At least the last 450mm (18") of the supply to the burner, and also any connections to the thermostat should run in flexible conduit to permit burner removal.

The supply **must** be properly earthed and wired as specified in the wiring diagram provided.

Air Supply

To ensure an adequate supply of air for combustion, the room in which the burner is installed must be permanently ventilated from a fresh air inlet of at least 450 sq. mm per kW (1 sq. per 5000 Btu/hr). This is in addition to any air requirements for other appliances.

COMMISSIONING

Bleed Air From Oil Supply

The method depends on whether the oil supply is gravity feed or suction lift.

Single Pipe System : Disconnect the oil pipe at the pump inlet. Open the stop valve slowly and run some oil into a receptacle to establish an air free supply to the pump. Re-make the connection oil tight and leave valve open.

Two Pipe System : Open oil valves, The pump is self-priming and the air bleeding should be automatic when the burner is subsequently started.

Fit Pressure Gauge

Remove plug from the pump and fit pressure gauge.

Check Motor Rotation (3phase motors only)

Remove the burner cover so that the fan can be observed. Switch on the electricity and observe during the slowing down of the motor, the direction of the rotation. It should be running clockwise when viewed from the air intake side. If incorrect, isolate the electrical supply, and change any two phases of the supply at the motor terminal box.

Air Inlet Settings

Set the air intake damper to the fully open position. For low firing rates (below 10gal/hr) where low combustion chamber pressure exists, set the damper to approximately one third open.

Hydraulically Operated Damper Setting

The damper positions are limited by the two friction nuts on the threaded spindle.

These should be adjusted with the cover removed, so that the two extreme positions of the damper can be observed. Viewing from the air intake side, the left nut sets the high-fire damper position, the right nut sets the low-fire position.

The damper may be moved against the tension of the spring, up to the stop, where its position can be measured. The high fire damper position should be about 80% open, and the low fire damper position about 20% open.

Burner Head Setting

The twin nozzle/flame ring assembly may be adjusted by slackening the screws which fasten the sealing plate. The assembly should now be free to slide. Guidance on setting is given in fig.2 Resecure the sealing plate screws.

Start Up

Switch on the electrical supply. The burner should run on pre-purge for 7 to 15 seconds, with the ignition spark energised. After this period the oil solenoid valve opens, admitting oil and allowing the burner to fire.

The burner may go to lockout, indicated by the illumination of the control box reset button. Air in the oil pump can cause flame instability and cause the burner to lockout. Wait at least one minute and depress the the reset button to restart, this procedure may require repeating.

Oil Pump Venting

While the burner is running, vent air from the pump by slackening the suction port screw sufficiently to allow air to bleed out. When bubble free oil seeps out, re-tighten the screw.

Oil Pressure Adjustment

Adjust pressure by turning the screw on the pump to achieve the desired reading. Once the pressure has been set, remove gauge and replace the plug.

Combustion Check

Check the CO₂ (Carbon Dioxide) at the appliance flue outlet using recognised combustion test instruments.

Adjustment to an optimum of approx. 12% is attained by :

High Fire

Slide the nozzle line assembly back to increase the CO₂, and forward to decrease the CO₂. This should be carried out in adjustment steps of 2mm, until the optimum CO₂ level is achieved.

Low Fire

Set the burner to low fire, and measure the CO₂. If necessary, alter the low fire damper position by adjustment of the appropriate friction nut on the threaded spindle, until the optimum CO₂ level is achieved.

Smoke No. Check

Using a smoke testing pump, check that the smoke in the flue gases does not exceed No. 1 on the scale after setting high fire position and No. 2 after setting the low fire position.

Check Ancillary Controls

Check that any thermostats or other safety limit controls are working correctly and are capable of switching the burner off.

Advise To User

Ensure that the user knows how to switch the burner off and where to close the main oil supply in the event of an emergency.

SERVICING

To maintain optimum performance and to avoid unnecessary breakdown, the burner should be checked two to three times a year and serviced annually by a qualified service engineer.

WARNING : Isolate the electricity supply before carrying out any service work.

ROUTINE MAINTENANCE

Clean Combustion Head

Remove cover plate
Disconnect oil pipe union nuts
Withdraw photocell
Unclip ignition leads and withdraw oil pipe assembly.
Wipe clean the flame ring and ignition electrodes taking care not to wipe the nozzle tip.
Re-assemble parts in reverse order
Switch on electricity supply at mains isolator switch
Switch on burner

Combustion Check

See commissioning section. If satisfactory test results cannot be obtained, the oil nozzle should be replaced. Ensure that the replacement nozzle is of the correct size, and spray angle/pattern.

Safety Control Check

After the burner has run for several minutes, remove the photocell and cover it to prevent exposure to light. After about 15 seconds the burner should lockout, this is indicated by the illumination of the reset button. Replace the photocell and depress the reset button.

MAJOR SERVICE

In addition to the routine maintenance checks the following should be carried out.

Clean Burner Thoroughly

Remove burner from the appliance and clean all parts to remove dust and deposits. Dirty fan blades may cause poor performance.

Clean Oil Line Filter

Close the oil supply valve and place a receptacle beneath the filter. Loosen the bowl retaining screw and remove the element. Wash the bowl and element in petrol or other suitable solvent. Replace the components, ensuring the bowl seats properly on to the sealing washer as the retaining bolt is tightened.

Clean Oil Tank Filter - If fitted

Remove Sludge From Oil Tank

Open the drain valve and draw off about two pints of oil into a suitable container, to remove any accumulation of water and deposits.

NOTE : If the fan is removed from the motor shaft, it should be securely refitted so that the rim of the impeller farthest from the motor is 62 mm from the motor flange.

FAULT FINDING

Symptoms & Possible cause	Remedy
Does Not Start No Electricity	Check that thermostats and time switches are in the energised position Check that there is a live supply to the the control box terminal/s Check fuses
Flame Detector	Switch off and inspect the photocell.Clean if required
Oil Pump or Motor Seized	Switch off the electricity supply, remove the air intake cover and turn the fan by hand. If the fan does not move freely then remove the motor shafts separately. replace the seized component.
Faulty Motor	Replace motor
Starts and Locks Out No Oil	Check that the oil valves are open. Unscrew the vent on the oil pump to check for the presence of oil. Check level of oil in storage tank.
No Ignition	Switch off and check the ignition leads are connected properly, and that the ignition electrodes are located and adjusted correctly.
Faulty Solenoid Valve	Check operation of solenoid valve and replace if required.
Photocell Exposed to Light	Check that the photocell is correctly positioned in the housing and that it is not exposed to extraneous light. Depress reset button for restart.
Photocell Faulty	Replace
Control Box Faulty	Replace
Burner Locks Out After An Unstable Start Combustion Head	Check setting and adjust as required
Air in Oil Line	Repurge pump and restart
Faulty/Blocked Nozzle	Replace
Air/Fuel Ratio	Adjust air intake to run burner, then check combustion
Burner Starts But With Large Smokey Flame High-fire solenoid valve letting by (but not enough pressure to open damper)	Clean foreign matter from valve seating Change valve if necessary
Hydraulic damper	Check operation of damper flap against its spring Replace hydraulic ram if necessary

FIG. 1:

TABLE (1) Nozzle Selection

Firing Rate *	US gal/h sizes of recommended pairs of nozzles (smallest sizes to be fitted in low fire position)			
US gal/h	(1) **		or	(2)
D.18 BURNER				
3.6	1.5	+ 1.5		1.35 + 1.65
3.7				1.35 + 1.75
3.8	1.5	+ 1.65		
3.9				1.5 + 1.75
4.0	1.65	+ 1.65		
4.1	1.65	+ 1.75		
4.2	1.75	+ 1.75		1.5 + 2.0
4.5	1.75	+ 2.0		
4.8	2.0	+ 2.0		1.75 + 2.25
5.1	2.0	+ 2.25		1.75 + 2.5
5.4	2.25	+ 2.25		

It is recommended that MONARCH 45°PLP nozzles should be used up to the 9.5 US gal/h size, then 60°PLP.

* at 10 bar (145 lb/sq. in) oil pressure. Intermediate rates may be obtained by adjusting the oil pressure in accordance with the formula:—

$$\text{Required pressure (bar)} = 10 \times \left(\frac{\text{Required Rate}}{\text{Rate at 10bar}} \right)^2$$

** the pairs of nozzles in column (1) will give approximately 2:1 turndown which should be satisfactory for most purposes. Where a higher turndown ratio is required those in column (2) will give about 2.3:1, or in event of a lesser ratio being required these pairs can be reversed (fitting the largest size in the low fire position) giving about 1.8:1.

FIG. 2.

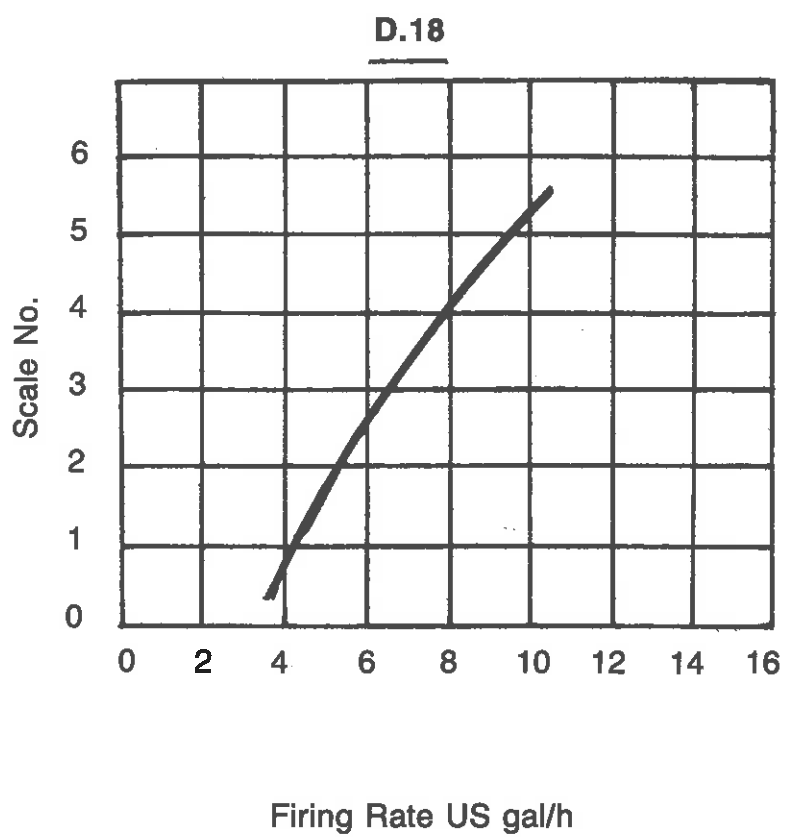
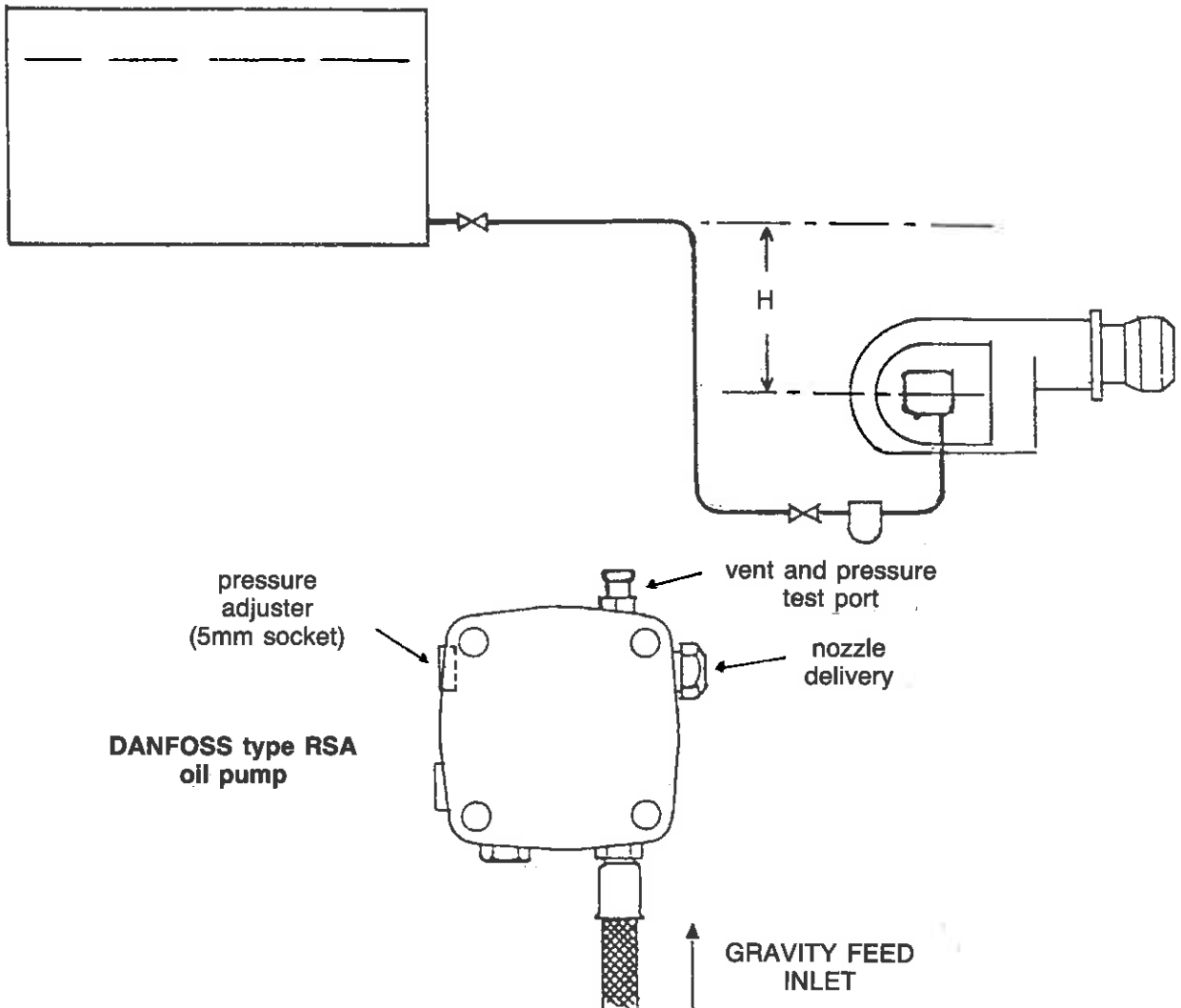

FIG. 3. SINGLE PIPE OIL SYSTEM



Height 'H' in metres	Firing rate in US gal/h:—															
	3 — 6		7 — 10		11 — 13			14 — 16			17 — 20			21 — 26		
	Allowable length of run for pipes of bore:—															
	6mm	8mm	6mm	8mm	6mm	8mm	10mm	6mm	8mm	10mm	6mm	8mm	10mm	6mm	8mm	10mm
0.5	—	2	—	2	—	1	3	—	1	2	—	—	2	—	—	1
1.0	6	20	4	13	3	10	24	3	8	20	2	11	16	2	5	12
1.5	12	38	8	25	6	19	46	5	15	37	4	13	31	3	9	23
2.0	17	55	12	37	9	28	67	7	22	54	6	18	45	4	14	34
2.5	23	73	15	49	12	36	89	9	29	77	8	24	59	6	18	44
3.0	29	91	9	60	14	45	100	11	36	88	10	30	74	7	23	55
3.5	34	100	23	72	17	54	100	14	43	100	11	36	88	9	27	66
4.0	40	100	27	84	20	63	100	16	50	100	13	42	100	10	31	77

Notes

1) The lengths, in metres, shown include allowance for 4 bends, 1 valve and 1 filter. For additional fittings reduce the allowable length by about half a metre for each.

2) The above table may be taken as valid for alternative makes of pump also, since for single pipe systems the limiting lengths and bores depend primarily on firing rate, so long as this does not exceed the maximum capacity of the pump.

FIG. 4. TWO PIPE OIL SYSTEM

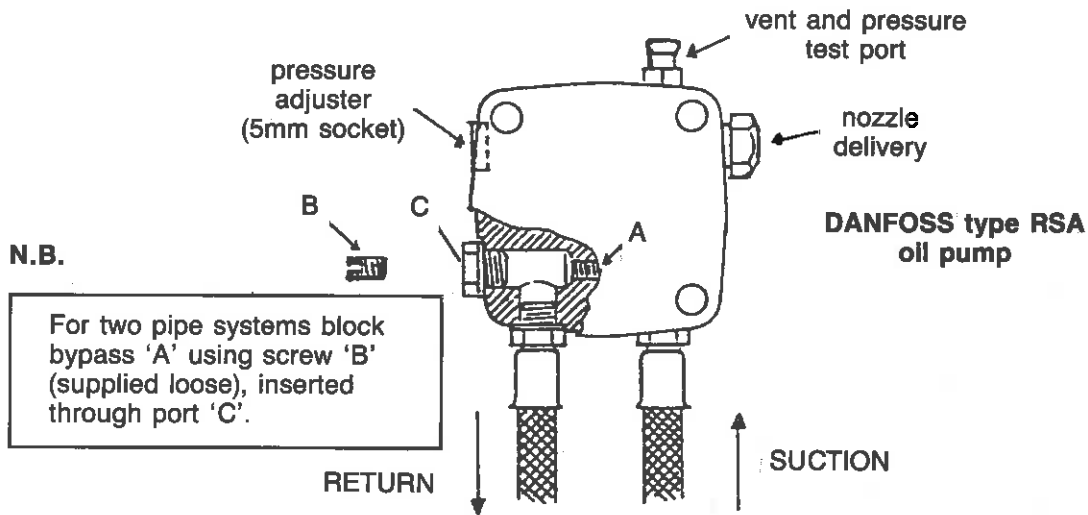
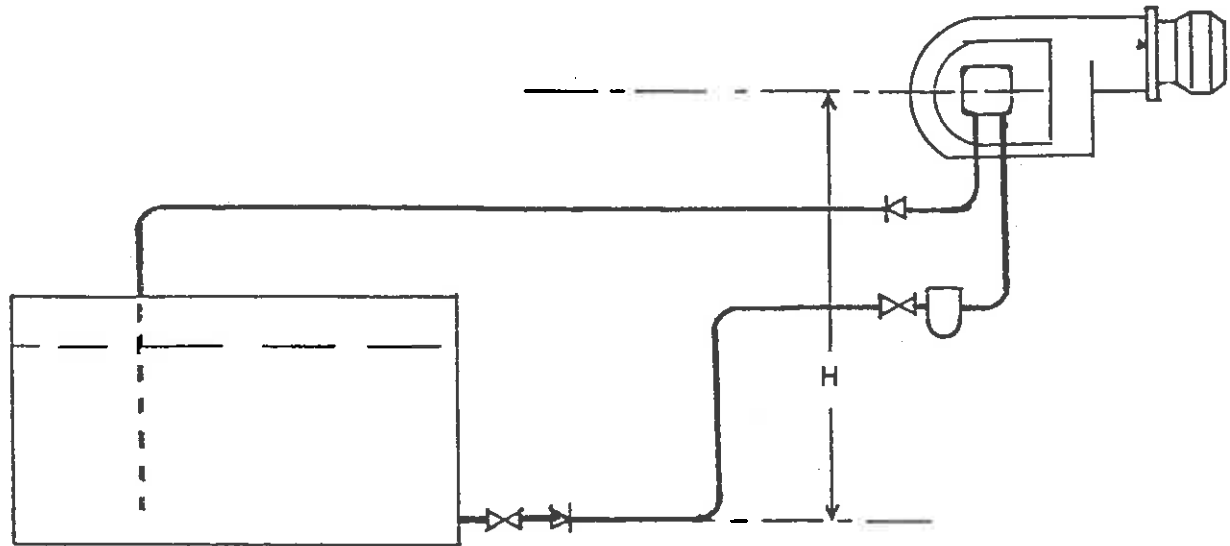

Height 'H' in metres	Allowable length of run for pipes of bore:—				
	6mm	8mm	10mm	12mm	15mm
D.18 burner / Danfoss RSA.40 pump					
0	10	34	83	100	100
0.5	9	30	73	100	100
1.0	8	25	63	100	100
1.5	6	21	52	100	100
2.0	5	17	42	88	100
2.5	4	13	32	67	100
3.0	—	9	22	45	100
3.5	—	4	11	24	59

Notes

- 1) The lengths, in metres, of pipe runs shown include some allowance for 4 bends, 1 valve, and 1 non-return valve in the suction line. For any extra fitting, filter, etc., reduce the allowable length by about half a metre.
- 2) The return line should be the same size as the suction line, but should only have a non-return valve.
- 3) The limiting heights and lengths are calculated to ensure that the suction at the pump inlet should not exceed 0.35 bar, to avoid risk of formation of vapour bubbles.

FIG. 5. D18A 1 PHASE TF802B CONTROL BOX

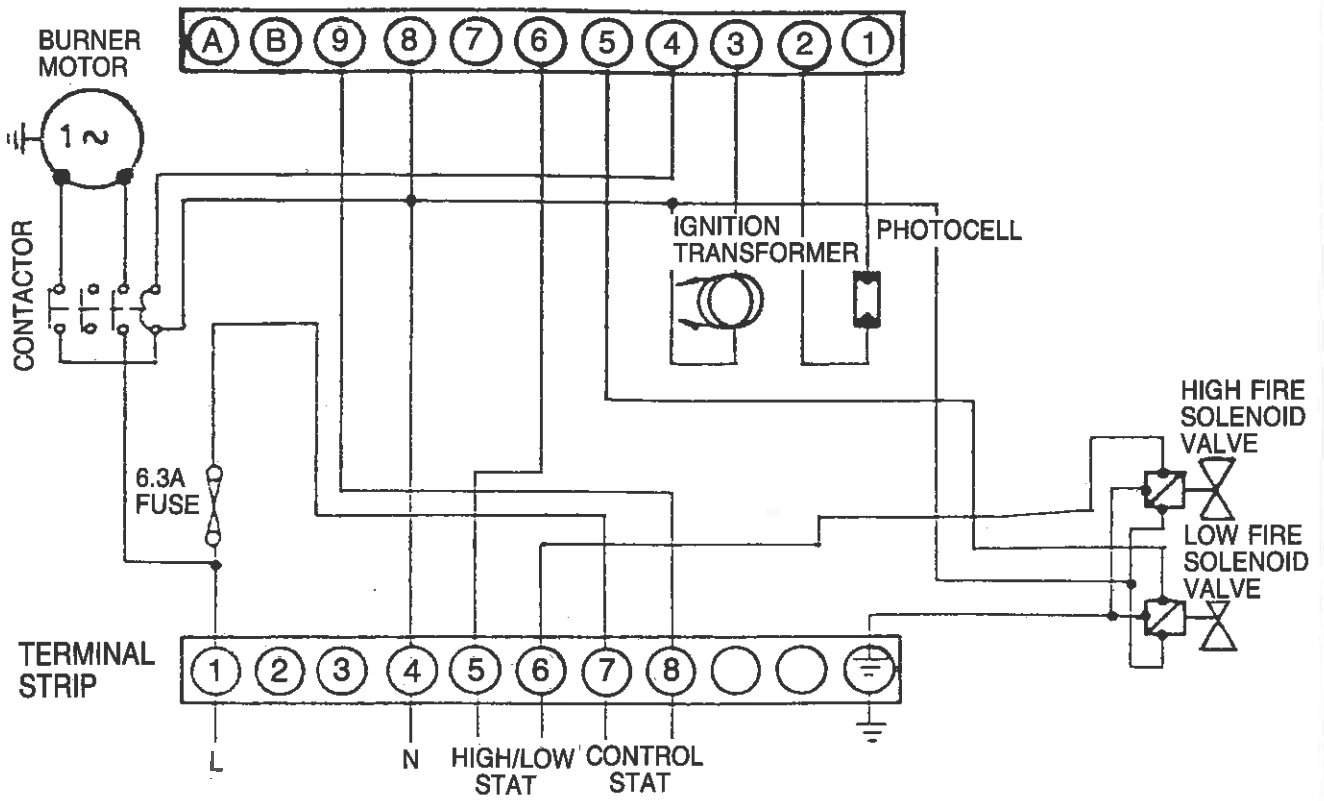

FIG. 6. D18 3 PHASE TF802B CONTROL BOX

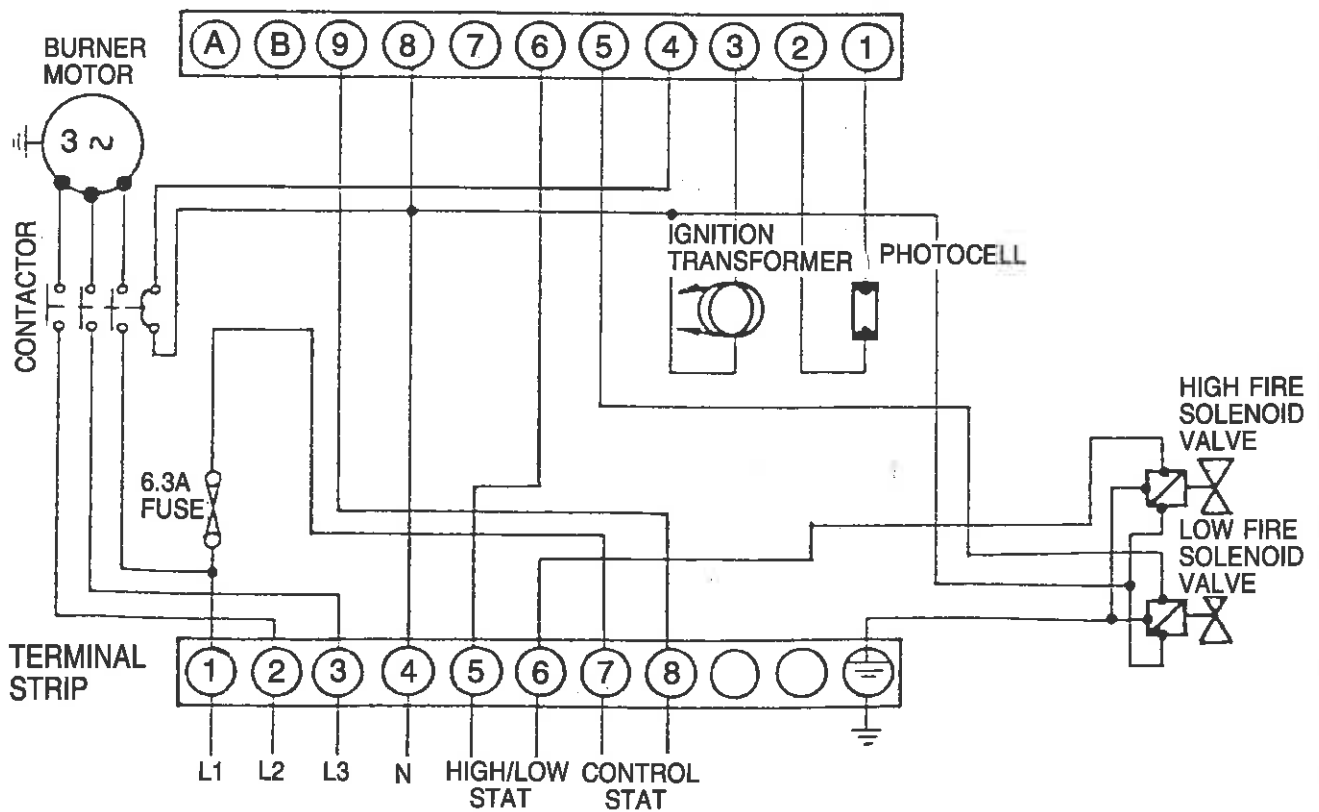

FIG. 7. D18 1 PHASE TTO 810 CONTROL BOX

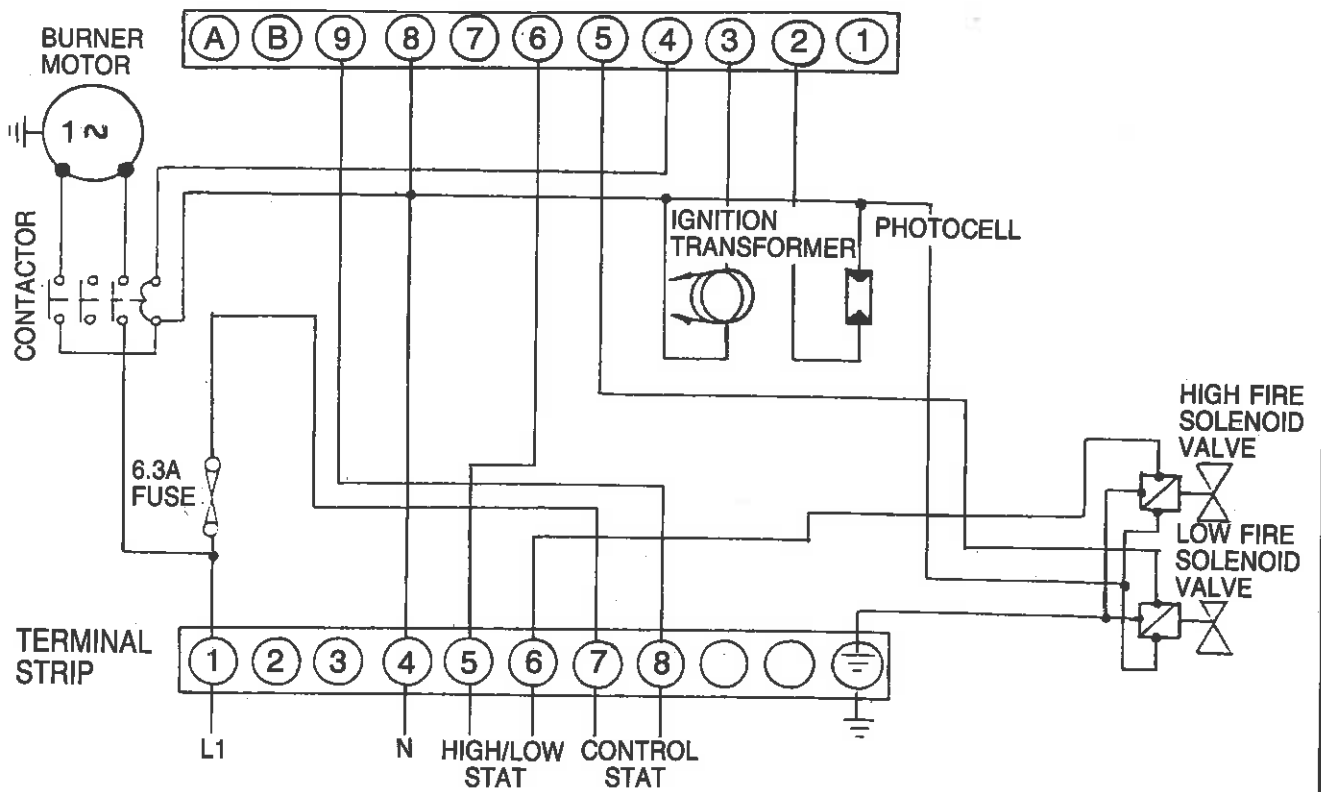
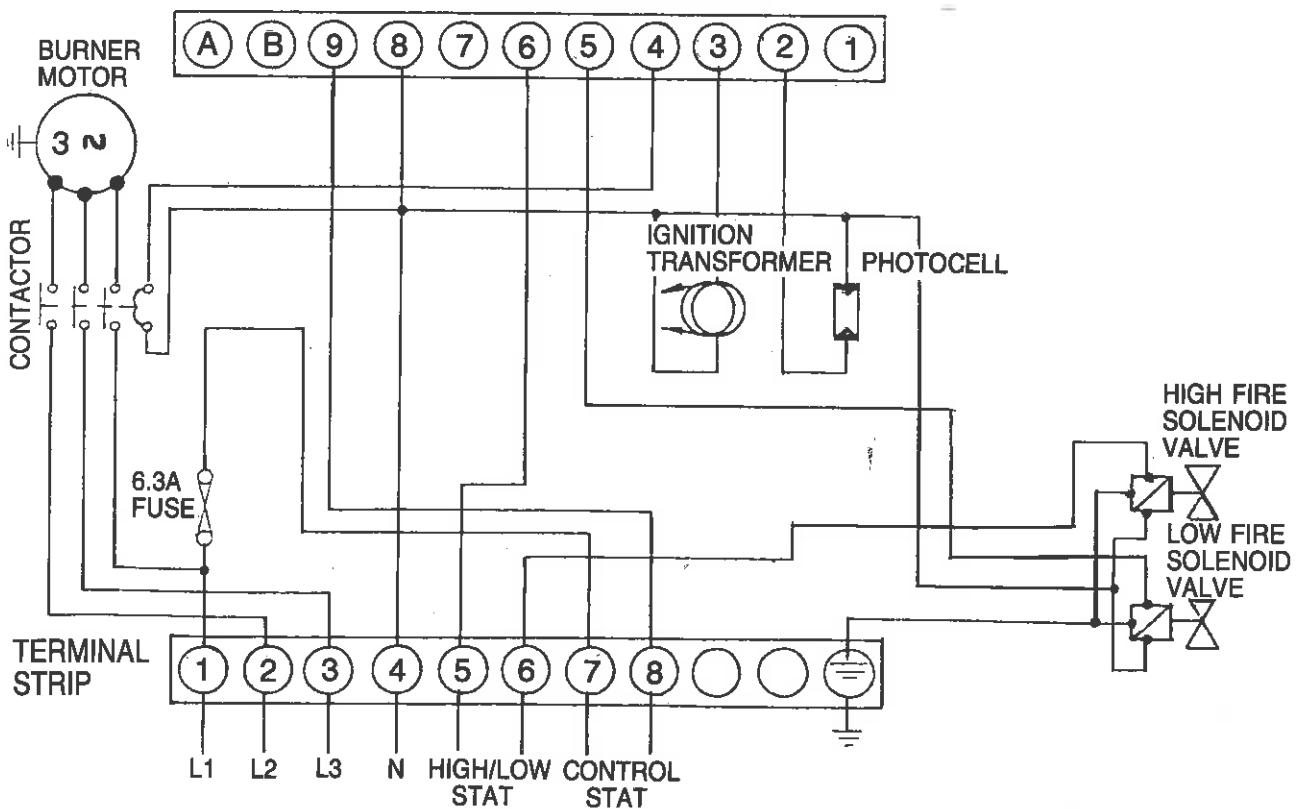

FIG. 8. D18 3 PHASE TTO 810 CONTROL BOX



MODELS

D 18A
D 18B
D 18C

ELECTRICAL DATA

Mains Supply 240V 1ph 50Hz
or 415V 3ph 50Hz

D18A motor 370W
D18B & D18C motor 550W

Start Current (A)	1ph	3ph
D18A	28	10
D18B & D18C	26	15

Run Current (A)	1ph	3ph
D18A	5	5
D18B & D18C	6	5

DIMENSIONS

All dimensions are in mm's

BURNER FIXING DETAILS

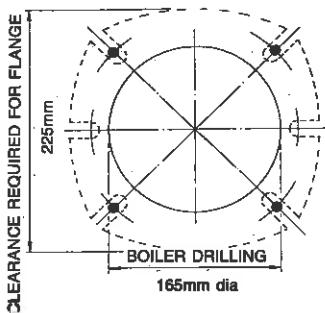

D18
FLANGE SLOTTED TO SUIT FOUR M12 x 45 LONG STUDS ON A 186min TO 230max PCD.
OR
TWO HORIZONTAL SLOTS TO SUIT M12 x 45 LONG STUDS ON 186min TO 203max CENTRES.

SELECTOS

Gas and Oil Burners

Selectos Burner Product Division.
Nu-way Ltd, P.O. Box1, Vines Lane,
Droitwich, Worcs. WR 8NA England.
Tel: (0905) 796568 & 794331.
Fax: (0905) 794017.
Telex: 338551 Nuway G

WOLSELEY plc
A member of the Wolseley plc Group

BURNER SELECTION CHART

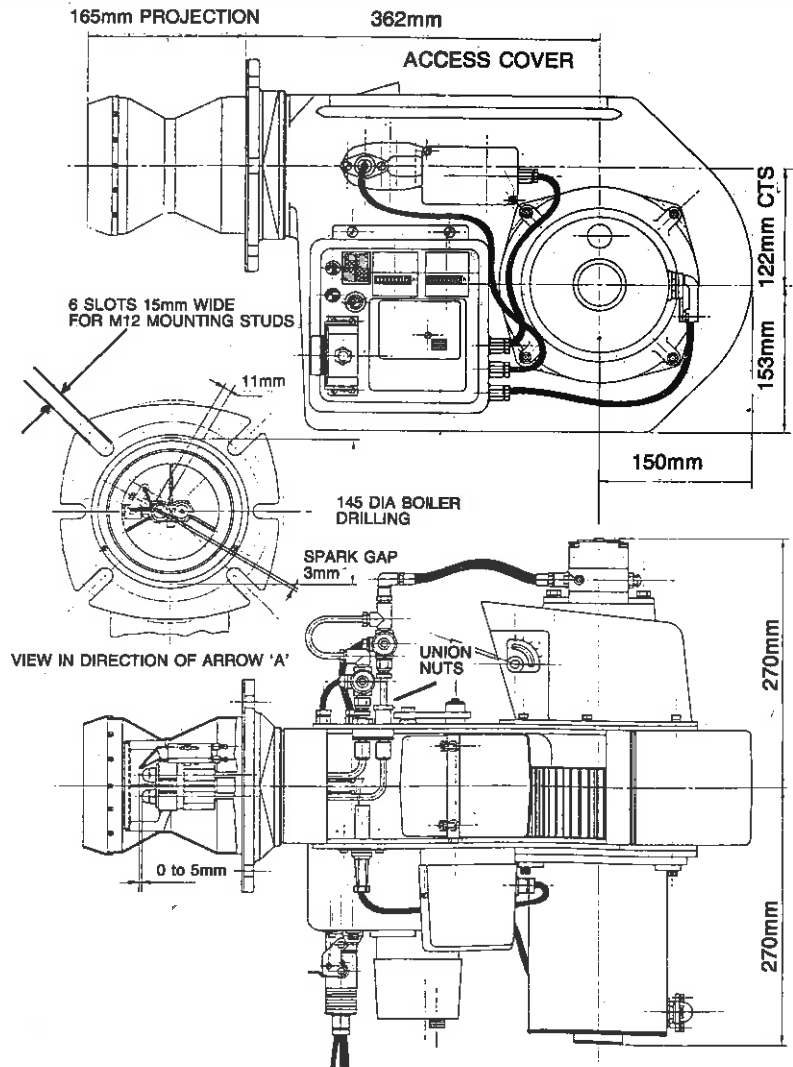
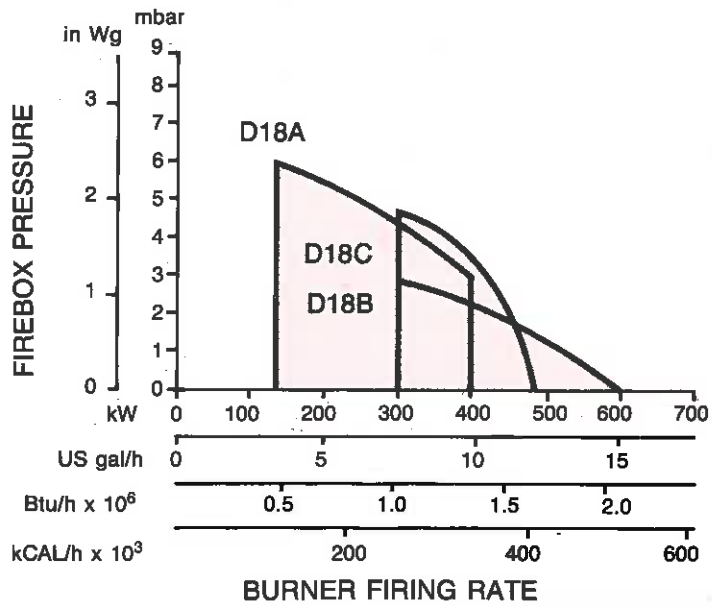

Nu-way policy is one of continuous improvement. The right to change prices and specifications without notice is reserved