

HANDBOOK

Series D Fully Automatic Oil Burners Models D 13A & D 13B

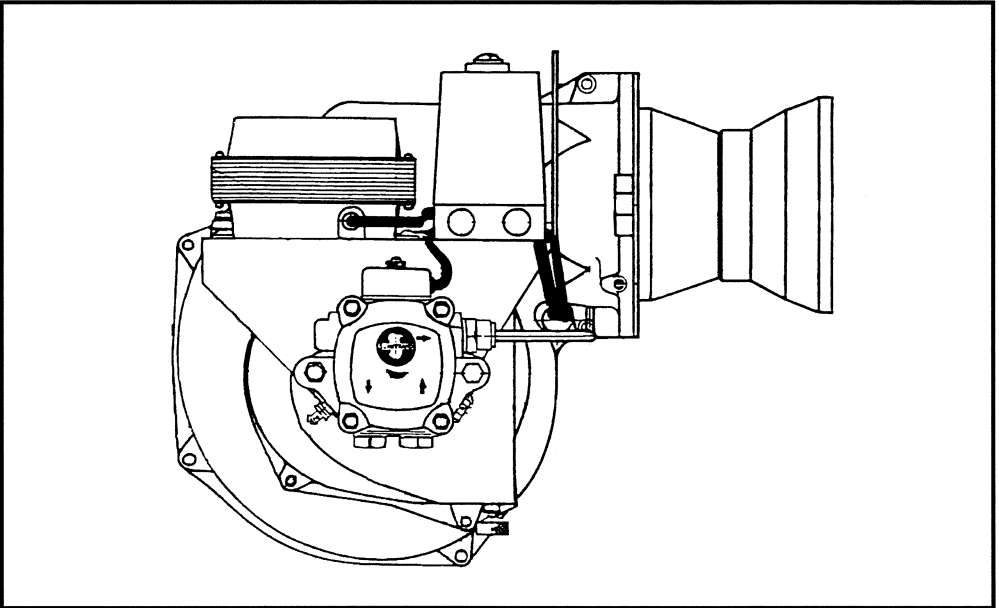

BURNER CAPACITY D13A

50kW to 100kW

170,000 Btu/h to 341,000 Btu/h

D13B

90kW to 180kW

307,000 Btu/h to 614,000 Btu/h

THE SELECTOS RANGE

The Selectos D13 range of fully automatic oil burners are designed to meet the requirements of BS 799.

The range is suitable for modern boilers, air heaters and process applications.

CONSTRUCTION

A monobloc metric design, the burner is suitable for flange mounting to the boiler/air heater frontplate.

AIR REGULATION

Air for combustion can be adjusted to give maximum efficiency.

CONTROLS

Flame supervision by miniature photo electric cell with sequence controller.

The burner operation may be controlled by thermostats, time switches etc.

OPERATION

Single Stage (On/Off) operation.

Two Stage (High/Low) and Low Flame Start (L.F.S.) are available on request.

FUEL

Class C2 (1:1 - 2.0cSt @ 4000) Kerosene or Class D (1.5-5.5cSt @ 40°C) Light Gas Oil.

FUEL SYSTEM

Pump fitted with solenoid cut-off valve, suitable for single pipe gravity feed or two pipe suction lift Systems.

It is recommended that an in-line fuel filter should always be fitted.

EUROPEAN BOILER DIRECTIVE (B.E.D.)

All burners and boiler bodies marked separately should comply with EN267 (oil burners) or (EN676) (gas burners) and EN303-1 (boiler bodies).

Burner adjustments must be made in accordance with boiler manufacturers instructions and these must include flue gas temperature, average water temperature and CO₂ or O₂ concentration.

INTRODUCTION

The D13 is a fully automatic oil burner, designed to meet the requirements of BS 799, and is suitable for modern boilers, air heaters and process applications. The burner should be installed and commissioned in accordance with these instructions by an experienced qualified engineer.

These instructions cover standard burner and general applications. Where the burner is supplied as part of a matched tested unit, the manufacturers recommendation regarding any specific combustion head settings etc. should be followed.

The burner is supplied complete with pre-wired controls. Electrical connections to the burner should be carried out in accordance with the wiring diagram supplied with the burner.

TECHNICAL DATA

CAPACITY			
D13A	min.	50kW	170,000 Btu/h
	max.	100kW	341,000 Btu/h
D13A	min.	90kW	307,000 Btu/h
	max.	180kW	614,000 Btu/h

Fuel

Class 02 (1.1 - 2.0cSt @ 4000) Kerosene or Class D (1.5 - 5.5cSt @ 40°C) Light Gas Oil.

Electrical Data

Mains Supply (V) 240 +10%-15% Single Phase Frequency (Hz) 50. Max power demand during ignition approx 600VA

Ambient Temperature

Maximum 60°C.

INSTALLATION

Pre-installation Check

Check that the operating combustion chamber pressure is within the range for the burner, and that the combustion head settings and nozzle are correct for the appliance to be fired (Fig.3).

Check the position of the offset fan intake nozzle (OFIN). This is carried out by removing the access cover. An embossed arrow on the inside of the housing is aligned with "H" (indicating High position), or "L" (low position). To change the setting, remove the adjacent screw, and rotate the OFIN to its new position and replace screw.

Burner Mounting

The burner should be securely mounted by means of the fixing flange, and gasket provided. The mounting flange and boiler drilling details are shown on the back cover of this handbook.

Fuel Supply

The oil supply from the storage tank to the burner should be run in copper, steel or aluminium pipe.

Galvanised pipes and fittings **SHOULD NOT** be used.

All pipework and fittings must be oil tight and screwed joints should be made good with an Oil resistant compound.

The supply should terminate close to the burner with a valve and filter, and the last 1/3 metre should be run in flexible oil pipe to facilitate removal of the burner during service and maintenance.

The size and arrangement of the pipework will depend on the distance and height of the storage tank in relation to the oil pump inlet on the burner.

Where the delivery connection on the tank is above the level of the oil pump inlet, a "Single Pipe System" (Fig 4) may be used. Where the delivery connection on the tank is below the level of the oil pump inlet, a "Two Pipe System" (Fig 5) must be used.

Electrical Supply

An isolating switch should be fitted as close as possible to the appliance and the supply protected by a fuse as specified in the Technical Data section.

At least the last 450mm (18") of the supply to the burner, and also any connections to the thermostat should run in flexible conduit to permit burner removal.

The supply must be properly earthed and wired as specified in the wiring diagram provided.

Air Supply

To ensure an adequate supply of air for combustion, the room in which the burner is installed must be permanently ventilated from a fresh air inlet of at least 450 sq. mm per kW (1 sq. per 5000 Btu/hr).

This is in addition to any air requirements for other appliances.

COMMISSIONING

Bleed Air From Oil Supply

The method depends on whether the oil supply is gravity feed or suction lift.

Single Pipe System : Disconnect the oil pipe at the pump inlet. Open the stop valve slowly and run some oil into a receptacle to establish an air free supply to the pump.

Re-make the connection oil tight and leave valve open.

Two Pipe System : Open oil valves, The pump is self-priming and the air bleeding should be automatic when the burner is subsequently started.

Fit Pressure Gauge

Remove plug from the pump and fit pressure gauge.

Start Up

Switch on the electrical supply. The burner should run on pre-purge for 7 to 15 seconds, with the ignition spark energised. After this period the oil solenoid valve opens, admitting oil and allowing the burner to fire. The burner may go to lockout, indicated by the illumination of the control box reset button. Air in the oil pump can cause flame instability and cause the burner to lockout. Wait at least one minute and depress the reset button to restart, this procedure may require repeating.

Oil Pump Venting

While the burner is running, vent air from the pump by slackening the suction port screw sufficiently to allow air to bleed out. When bubble free oil seeps out, re-tighten the screw.

Oil Pressure Adjustment

Adjust pressure by turning the screw on the pump to achieve the desired reading. Once the pressure has been set, remove gauge and replace the plug.

Combustion Check

If the OFIN is in the "High" position, set the air inlet flap fully open. If the OFIN is in the "Low" position, set the air inlet flap to about one third open.

Check the CO₂ (Carbon Dioxide) at the appliance flue outlet using recognised combustion test instruments. Adjustment to an optimum of approx. 12% is attained by slackening the screw and moving the inner assembly backwards to increase or forwards to decrease. Re-tighten screw when the desired position is attained. Further fine tuning by adjustment of the air intake flap may be required.

Smoke No. Check

Using a smoke testing pump, check that the smoke in the flue gases does not exceed No. 2 on the scale.

Check Ancillary Controls

Check that any thermostats or other safety limit controls are working correctly and are capable of switching the burner off.

Advise To User

Ensure that the user knows how to switch the burner off and where to close the main oil supply in the event of an emergency.

SERVICING

To maintain optimum performance and to avoid unnecessary breakdown, the burner should be checked two to three times a year and serviced annually by a qualified service engineer.

WARNING: Isolate the electricity supply before carrying out any service work.

ROUTINE MAINTENANCE

Clean Combustion Head

Remove cover plate

Disconnect oil pipe union nut

Withdraw photocell

Unclip ignition leads and withdraw oil pipe assembly.

Wipe clean the flame ring and ignition electrodes taking care not to wipe the nozzle tip.

Re-assemble parts in reverse order
Switch on electricity supply at mains isolator switch

Switch on burner

Combustion Check

See commissioning section. If satisfactory test results cannot be obtained, the oil nozzle should be replaced. Ensure that the replacement nozzle is of the correct size, and spray angle/pattern.

Safety Control Check

After the burner has run for several minutes, re-move the photocell and cover it to prevent exposure to light. After about 15 seconds the burner should lockout, this is indicated by the illumination of the reset button. Replace the photocell and depress the reset button.

MAJOR SERVICE

In addition to the routine maintenance checks the following should be carried out.

Clean Burner Thoroughly

Remove burner from the appliance and clean all parts to remove dust and deposits. Dirty fan blades may cause poor performance.

Clean Oil Line Filter

Close the oil supply valve and place a receptacle beneath the filter. Loosen the bowl retaining screw and remove the element. Wash the bowl and element in petrol or other suitable solvent. Replace the components, ensuring the bowl seats properly on to the sealing washer as the retaining bolt is tightened.

Clean Oil Tank Filter - If fitted

Remove Sludge From Oil Tank

Open the drain valve and draw off about two pints of oil into a suitable container, to remove any accumulation of water and deposits.

NOTE: If the fan is removed from the motor shaft, it should be securely refitted so that the rim of the impeller farthest from the motor is 62mm from the motor flange.

FAULT FINDING

Symptoms & Possible cause	Remedy
Does Not Start No Electricity	Check that thermostats and time switches are in the energised position. Check that there is a live supply to the control box terminal/s. Check fuses.
Flame Detector	Switch off and inspect the photocell. Clean if required.
Oil Pump or Motor Seized	Switch off the electricity supply, remove the air intake cover and turn the fan by hand. If the fan does not move freely then remove the motor shafts separately. replace the seized component.
Faulty Motor	Replace Motor.
Starts and Locks Out No Oil	Check that the oil valves are open. Unscrew the vent on the oil pump to check level of oil in storage tank.
No Ignition	Switch off and check the ignition leads are connected properly and that the ignition electrodes are located and adjusted correctly.
Faulty Solenoid Valve	Check operation of solenoid valve and replace if required.
Photocell Exposed to Light	Check that the photocell is correctly positioned in the housing and that it is not exposed to extraneous light. Depress reset button for restart.
Photocell Faulty	Replace.
Control Box Faulty	Replace.
Burner Locks Out After An Unstable Start Combustion Head	Check setting and adjust as required.
Air in Oil Line	Repurge pump and restart.
Faulty/Blocked Nozzle	Replace.
Air/Fuel Ratio	Adjust air intake to run burner, then check combustion.

FIG. 1. SATRONIC TF830B WIRING DIAGRAM

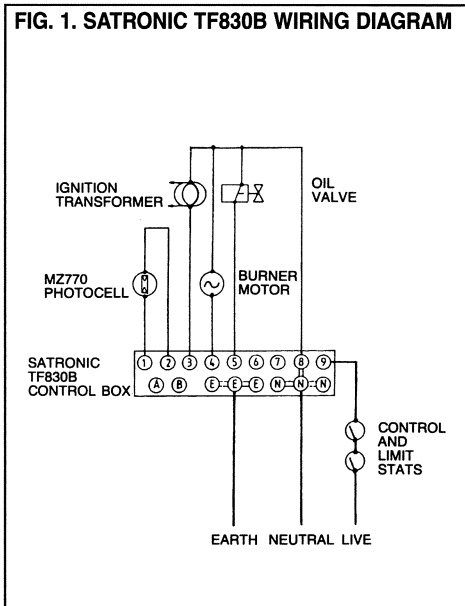

FIG. 2. DANFOSS BH011 WIRING DIAGRAM

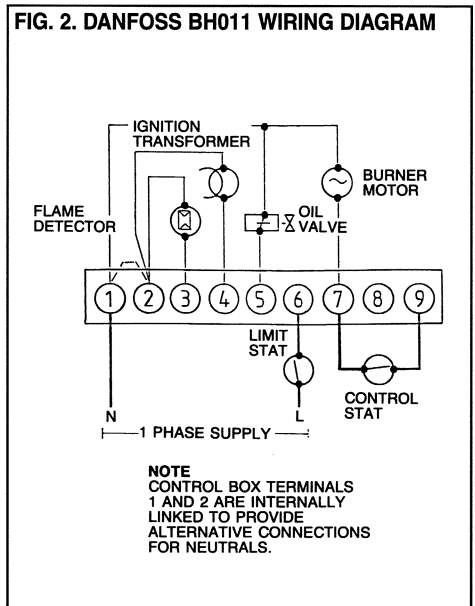

FIG. 3. NOZZLE SELECTION AND SETTINGS

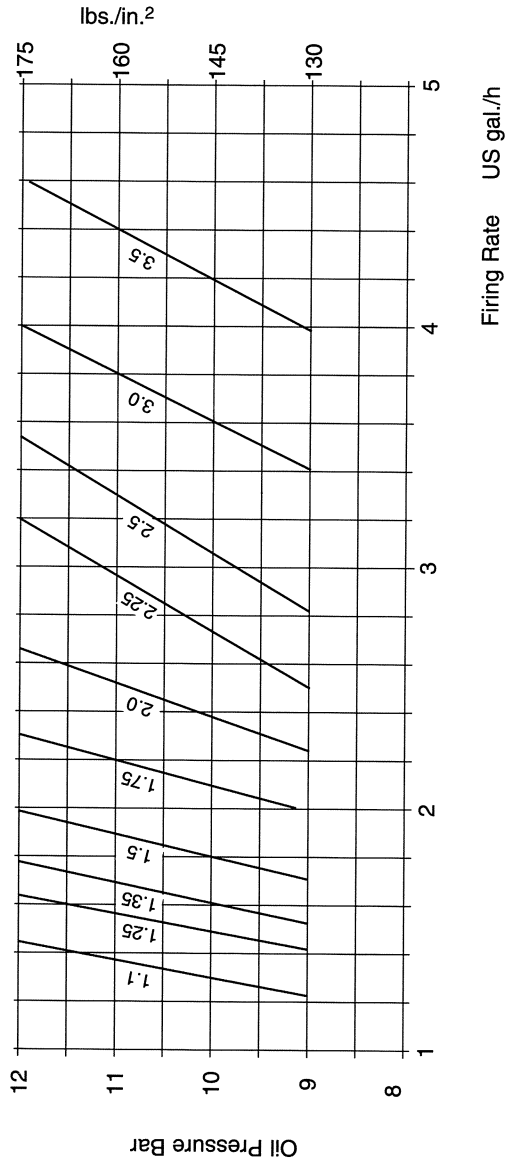
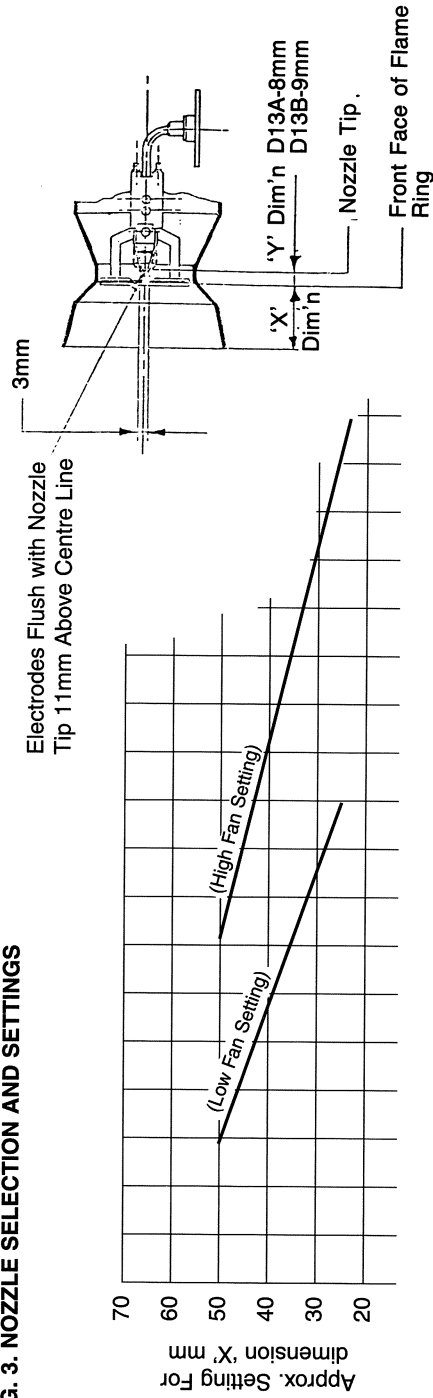
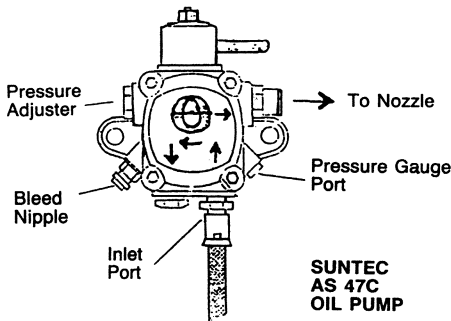
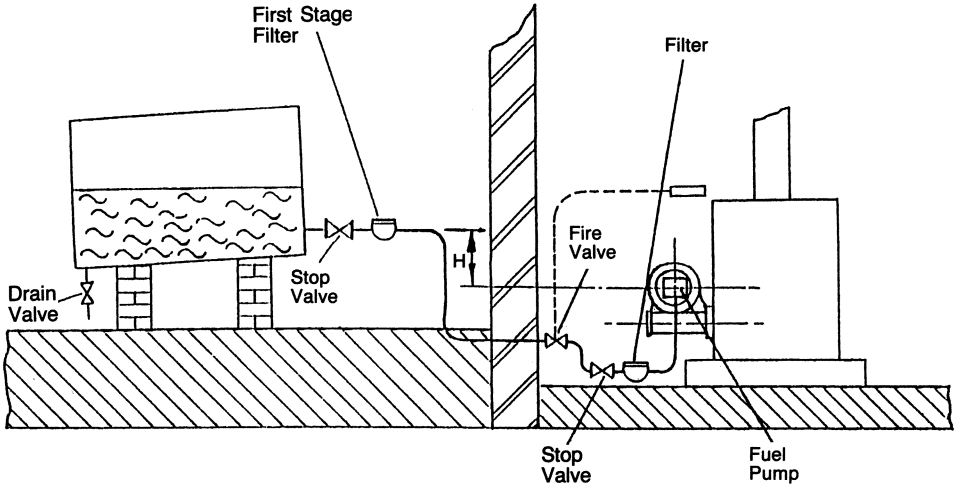
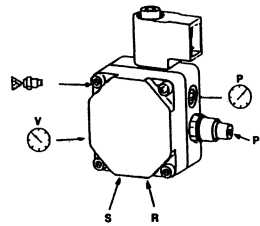

FIG. 4. SINGLE PIPE SYSTEM FUEL SYSTEM



**SUNTEC
AS 47C
OIL PUMP**



- P₁ Pressure regulation
- S Suction line 1/4 in BSP
- R Return line 1/4 in BSP
- Nozzle connection 1/4 in BSP
- Pressure gauge connection 1/4 in BSP
- Vacuum meter connection 1/4 in BSP

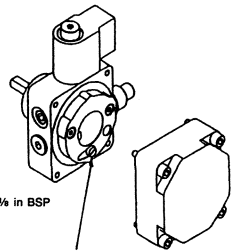

**DANFOSS
BFP
OIL PUMP**

1 — Pipe operation
Screw not fitted

Maximum allowable length for pipe bore.

Head	H m	Ø4 mm	Ø5 mm	Ø6 mm	Ø4 mm	Ø5 mm	Ø6 mm
	5.0	37	89	100	18	45	92
	3.5	32	78	100	16	39	81
	3.0	27	67	100	14	33	69
	2.5	23	56	100	11	28	58
	2.0	18	45	92	9	22	46
	1.5	14	33	69	7	17	35
	1.0	9	22	46	5	11	23
	0.5	5	11	23	2	6	12
Nozzle capacity		2.5kg/h			5.0kg/h		

#

This is the length of straight pipe. Deduct say 1/2m for each bend or fitting and 4m for each valve or filter in determining the actual allowable length of pipe run.

FIG. 5. TWO PIPE SYSTEM FUEL SYSTEM

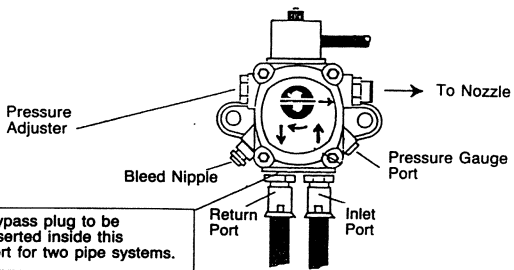
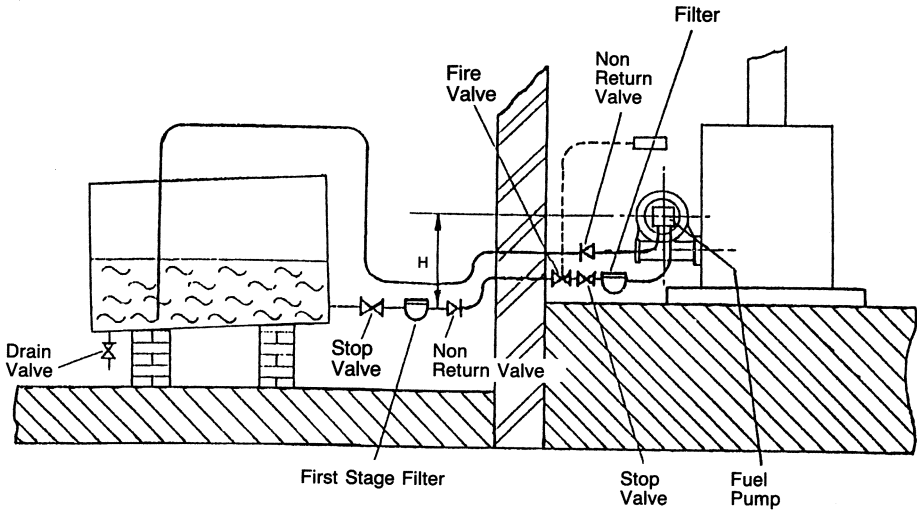

N.B. Bypass plug to be inserted inside this port for two pipe systems.

SUNTEC AS 47C OIL PUMP

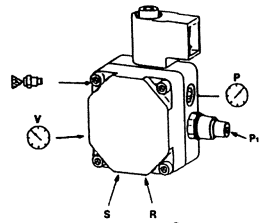

- P₁ Pressure regulation
- S Suction line 1/4 in BSP
- R Return line 1/4 in BSP
- ⊕ Nozzle connection 1/4 in BSP
- P Pressure gauge connection 1/4 in BSP
- V Vacuum meter connection 1/4 in BSP

DANFOSS BFP OIL PUMP

2 — Pipe operation
Fit screw as shown

Maximum allowable length for pipe bore.

Lift	H m	Ø6 mm	Ø8 mm	Ø10 mm
	4.0	21	67	100
	3.5	20	62	100
	3.0	18	58	100
	2.5	17	54	100
	2.0	16	50	100
	1.5	15	46	100
	1.0	13	42	100
	0.5	12	38	92

This is the length of straight pipe. Deduct say 1/2m for each bend or fitting and 4m for each valve or filter in determining the actual allowable length of pipe.

MODELS

D 13A

D 13B

ELECTRICAL DATA

Mains Supply (V) 240 + 10%-15%
 Single Phase
 Frequency (Hz) 50

DIMENSIONS

All dimensions are in mm's

FLANGE FIXING DETAILS

FLANGE TO SUIT FIXING STUDS UP
 TO M12 FROM 140 TO 170 CTRS

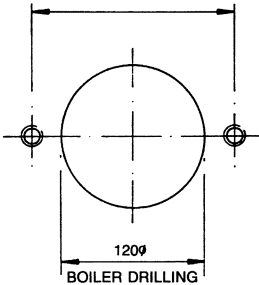

BURNER SELECTION CHART

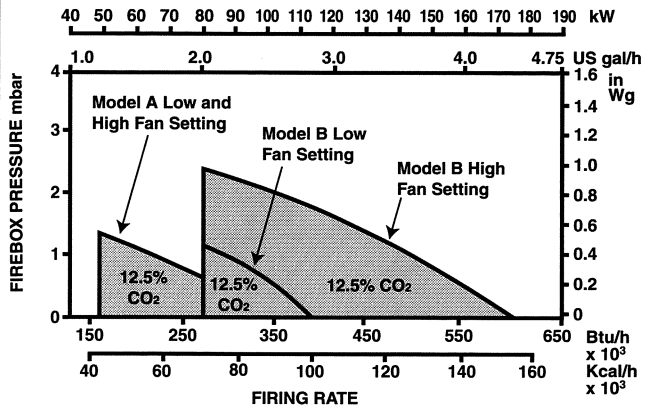

DIMENSIONS

All dimensions are in mm's

FLANGE FIXING DETAILS

FLANGE TO SUIT FIXING STUDS UP
 TO M12 FROM 140 TO 170 CTRS

