



automatic oil burners

MODEL
C2-15

The Nu-way C2 pressure jet burner is designed to meet the requirements of all international markets, having a range of output from 59–256 kW (50,400–220,500 kcal/h: 200,000–875,000 Btu/h). Available for on/off operation, it is able to fire, at reduced thermal output, appliances having resistances as listed under the burner selection chart. Burners can also fire appliances having a maximum draught in the combustion chamber of 10.0 Pa (1 mm wg: 0.04 in wg) at full appliance rating.

FUEL

Light distillate oil (up to 40 sec Redwood No 1 at 38°C: 5.7 cSt at 38°C).

FUEL SYSTEM

Suitable for single pipe gravity feed or two pipe suction lift systems. A fuel filter is provided; fuel connection $\frac{1}{2}$ " BSP female thread.

CONSTRUCTION

Monobloc metric design using fasteners to ISO standards. Body hinged for access to fan and inner assembly. Adjustable burner head maintains high air velocity and gives maximum combustion efficiency throughout burner range. Solenoid valve is integral part of pump.

AIR CONTROL

Rotary type device for final control of combustion conditions. Burner fitted with patented air control device producing smoother starting conditions.

CONTROLS

Flame supervision by photo electric cell with sequence controller. The burner may be controlled by suitable thermostats, time switches, frost thermostats etc.

OPTIONAL EXTRAS

Versions to burn Kerosene (28 sec Redwood No 1 at 38°C: 1.4 cSt at 38°C) available on request.

WEIGHT

13.5 kg.

ELECTRICAL DATA

Mains supply (V)	230+10%–15%
	1 ph 50 Hz
Burner motor (W)	150
	2700 rev/min, capacitor start
Burner start current (A)	1.5
Burner run current (A)	0.94
Ignition	Direct spark from 10 kV 23 mA transformer, centre tap earthed

BURNER SELECTION

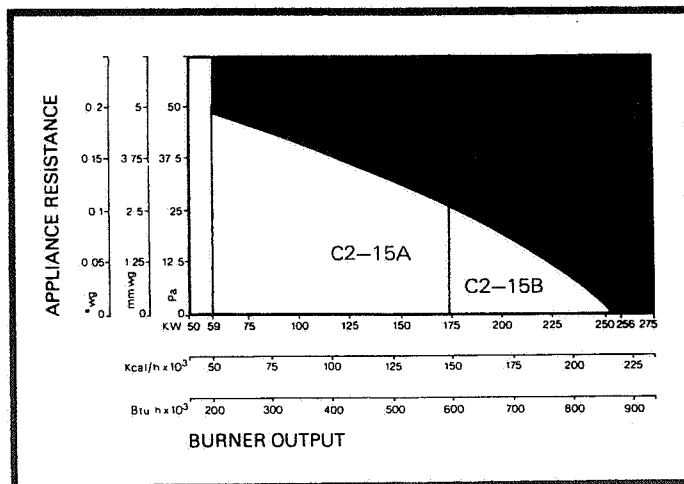

DIMENSIONS

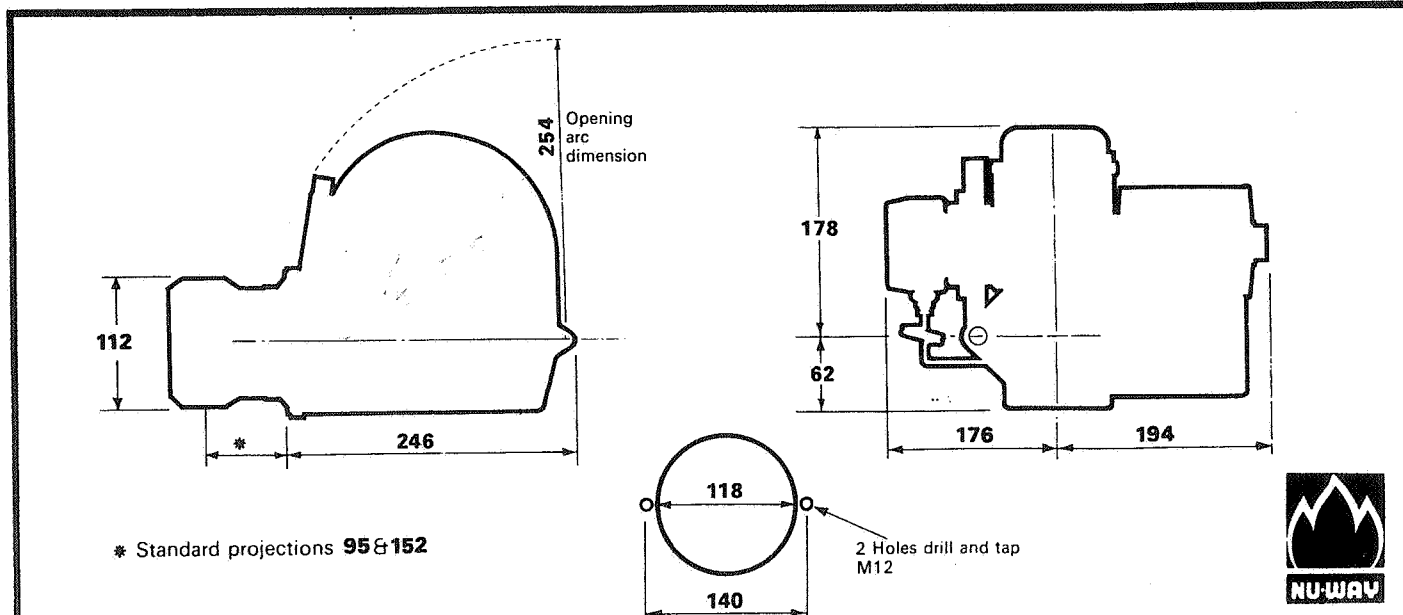

NU-WAY

BURNER DATA

Burner Model	Minimum Burner capacity‡			Maximum Burner capacity‡			Diffuser diameter mm	Minimum Burner Throughput*		Maximum Burner Throughput*		Nozzle Spray Angle ††
	kW	kcal/h x 10 ³	Btu/h x 10 ³	kW	kcal/h x 10 ³	Btu/h x 10 ³		Litres/h	USgal/h	Litres/h	USgal/h	
C2A	59	50.4	200	183	157.4	624.5	85	5.49	1.25 1.45	17.18	3.8 4.54	60°
C2B	183.1	157.5	625	256	220.5	875	70	17.22	2.4 4.55	24.07	5.3 6.36	60°

Notes:

Pump pressure of 965 kPa (9.8 Kg/cm²: =140 psi) is factory-set standard.

‡ Ratings are based on negative draught over flame of 0.005 kPa (0.5 mm wg = 0.02 in wg)

†† Nozzles: A size—Steinen Q up to 11.4 litres/h (3.0 US gph) and Monarch PLP or AR above; B size—Monarch PLP or Steinen SS.

* Based on calorific value of 10.6 kW/litre (137500 Btu's/US gal).

INSTALLATION

Flue. The top of the chimney should be above all roofs within a radius of 10 m.

Ensure that the flue pipe from the appliance finishes flush with the inside wall of the chimney.

If draught over the fire exceeds 0.02 kPa (2 mm wg: 0.08 in wg) draught stabiliser should be fitted in a position recommended by the appliance maker. Draught over the fire when the burner is operating should be between 0.012 and 0.05 kPa (1.25—5 mm wg: 0.05—0.2 in wg).

Fuel supply (and, where fitted, return) pipes should consist of metal tube (NEVER galvanised steel), the final connection to the burner pump inlet port being made with the length of flexible pipe supplied with the burner.

When gravity feed is used (the most common), the maximum head should not exceed 4 m (equivalent to a pressure of 35 kPa).

On installations where the fuel tank is situated below the level of the burner the maximum suction permitted is 40 kPa (300 mm Hg) and a two-pipe (supply and return) fuel supply system MUST be used.

Note that the pump is factory set for single pipe installation.

When using a two-pipe system refer to the pump details for pump modification.

If installation is a two-pipe system, it is essential to ensure that the return pipe is not obstructed in any way, eg by a plug, closed valve, etc. Any obstruction will damage the pump.

Pump priming. Loosen the vent plug. Connect purge port to suitable container.

On single pipe (gravity fed) systems, the pump should be primed under gravity from the tank. If a two-pipe system is used, the suction line will require priming before energising the pump mechanically.

The pump may need priming also, if the oil storage tank is allowed to drain completely.

Electricity supply. Connect suitable electrical supply to burner, thermostats, time switches, etc., as appropriate.

AIR CONTROL

The C2-15 incorporates an externally adjustable diffuser plate (flame stabilising disc), which can be moved by approximately 20 mm, and gives a partial air control against the expanding cone of the draught tube.

This enables air pressure over the burner head to be maintained throughout the burner range, with improved combustion results.

The rotary air damper is used as a trimming device to set final combustion requirements.

A diffuser plate of 85 mm diameter is used up to 183 kW (C2A) with a 70 mm diameter diffuser plate up to 256 kW (C2B).

PRE-FIRING CHECK & INITIAL SETTINGS

- (1) Remove nozzle assembly and carry out instructions shown in maintenance photographs.
- (2) Check or fit nozzle of correct size/angle for appliance (if already fitted check for tightness).
- (3) Ensure electrode setting is correct (drawing in maintenance section) and diffuser is in appropriate position (following notes and sketch).
- (4) Replace nozzle assembly.
- (5) The setting of the burner diffuser plate (adjustment 20mm) is carried out by loosening the two screws (first remove plastic insets) retaining the inner assembly adjustment plate. The position is indicated by a triangular red marker and when the nozzle pipe is opposite O, the diffuser is fully back giving highest resistance to air flow.

When the nozzle pipe is moved fully forward (approx. 20mm) there is least resistance at the diffuser and consequently higher air throughput.

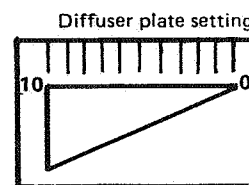

To determine setting the following instructions should be carried out:

C2 (A SIZE)

- (a) 59—103 kW (50400—89000 kCal/h = 2000000—350000 Btu/hr) adjust to position 0 in sketch (diffuser fully back). The rotary air damper should be approximately 6mm open.
- (b) 104—146 kW (89500—126000 kCal/h = 355000—500000 Btu/hr) adjust to position 4 in sketch (diffuser mid-position). The rotary air damper should be approximately 12mm open.
- (c) 147—183 kW (127000—157500 kCal/h = 502000—625000 Btu/h) adjust to position 8 in sketch (diffuser fully forward). The rotary air damper should be in the fully open position.

C2 (B SIZE)

- (a) 184–220 kW (158000–189000 kCal/h = 626000–750000 Btu/h) adjust to position 4 in sketch (diffuser mid-position). The rotary air damper should be 20mm open.
- (b) 221–256 kW (190000–220500 kCal/h = 754000–875000 Btu/h) adjust to position 8 in sketch (diffuser fully forward). The rotary air damper should be in the fully open position.

GENERAL

The rotary air damper should be used as a final adjustment with the diffuser set in the appropriate position. Obviously variation of both settings are necessary to cater for all appliances. Optimum combustion results are obtained by using the maximum air pressure available across the diffuser plate and adjusting air damper to obtain acceptable CO₂ and smoke values.

OIL PUMP AND LINE DETAILS—DANFOSS MSLA 032 PUMP ONLY

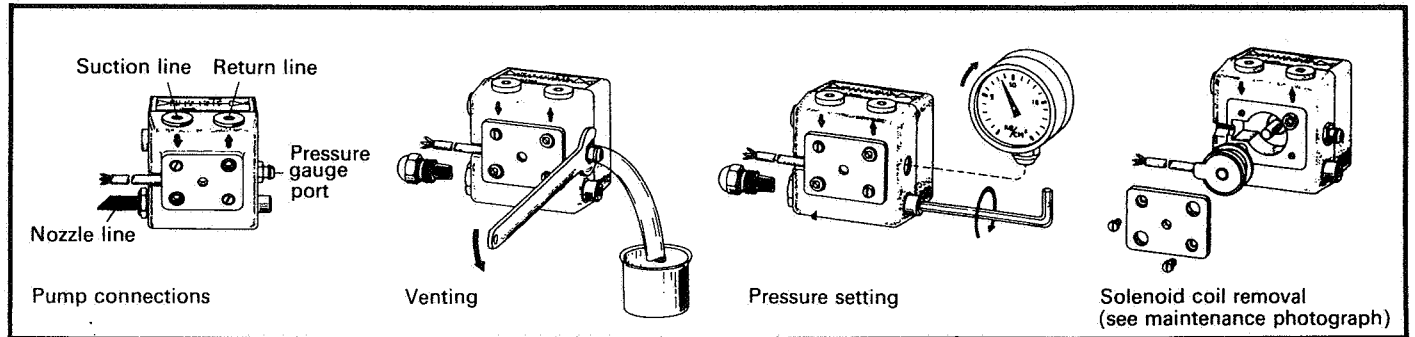

One pipe system to be used only when there is a positive pressure in the suction line.

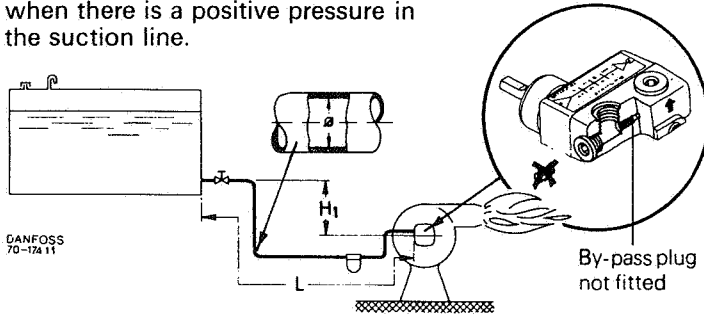

Two-pipe system to be used when a vacuum may occur in suction line.

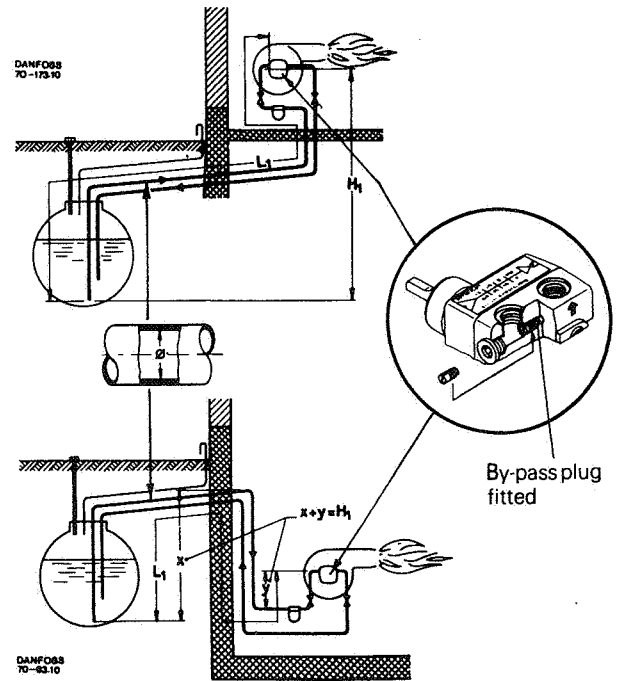

Danfoss	4.3 c.St. (20°C)											
H	ø4 mm	ø5 mm	ø6 mm	ø4 mm	ø5 mm	ø6 mm	ø4 mm	ø5 mm	ø6 mm	ø4 mm	ø5 mm	ø6 mm
3.0	58	100	100	28	67	100	18	44	91	14	22	71
2.5	48	100	100	23	56	100	15	36	74	11	18	58
2.0	35	86	100	18	43	89	11	27	57	9	17	45
1.5	24	60	100	12	30	63	8	19	40	6	12	31
1.0	14	35	72	7	17	36	5	11	23	4	7	18
0.5	4	9	19	2	4	9	1	3	6	1	2	5
Nozzle capacity	1.9–2.7 litres/h 0.5–0.71 US gph			2.7–4.9 litres/h 0.71–1.30 US gph			4.9–7.5 litres/h 1.30–2.0 US gph			8.3–12.1 litres/h 2.2–3.2 US gph		
H	ø4 mm	ø5 mm	ø6 mm	ø8 mm	ø4 mm	ø5 mm	ø6 mm	ø8 mm	ø4 mm	ø5 mm	ø6 mm	ø8 mm
3.0	7	17	45	100	5	14	35	100	4	11	28	90
2.5	5	13	37	100	4	10	28	91	3	8	23	73
2.0	3	9	28	90	3	7	22	70	2	6	17	56
1.5	2	5	20	63	—	4	15	49	—	3	12	39
1.0	—	—	11	36	—	—	8	28	—	—	7	22
0.5	—	—	2	9	—	—	2	7	—	—	—	5
Nozzle	14.5 litres/h			19.4 litres/h			24.2 litres/h					

Danfoss	4.3 c.St. (20°C)			Danfoss	4.3 c.St. (20°C)		
H	ø8 mm	ø10 mm	ø12 mm	H	ø8 mm	ø10 mm	ø12 mm
3.0	95	100	100	-0.5	48	100	100
2.5	89	100	100	-1.0	41	100	100
2.0	82	100	100	-1.5	35	85	100
1.5	75	100	100	-2.0	28	68	100
1.0	68	100	100	-2.5	21	52	100
0.5	62	100	100	-3.0	14	35	73

NU-WAY

OPERATION

To start burner turn main electricity isolating switch and, where fitted, separate burner switch, to ON.

The burner can be stopped in an emergency by opening the electrical switch provided in the line between the burner and the electricity supply.

There is a pre-purge period during which the ignition is switched on, and the motor runs.

At the end of this period, pump solenoid valve is energised allowing oil flow to nozzle, burner lights.

After a further period the ignition is switched off and the burner continues to run until it is switched off by:-

- (a) the control thermostat contacts opening upon the room or water temperature being reached
- or (b) safety or limit thermostat contacts opening
- or (c) burner is switched off manually.

If, during start up, the flame fails to be established the photo cell will detect this and will shut down the burner and the 'lock out' lamp in the sequence control box is automatically lit.

If, during normal running, the flame is extinguished, the ignition spark is restored within 1 second. If burner fails to re-light it goes to 'lock out' after 15 seconds.

The manual reset button, also on the sequence control box, should not be operated until at least 30 seconds after the burner has been 'locked out'.

When appliance has reached its normal working temperature, final adjustments may be necessary to obtain optimum firing conditions.

FAULT FINDING

Motor fails to start. Check that power is available to the burner. Check all fuses in the supply to the burner. Check that the contacts of both control and safety limit thermostats on the appliance or in the room are closed, and therefore 'calling for heat'. If these thermostat contacts are not closed check the thermostat settings.

ELECTRICAL CONNECTIONS

Danfoss 57H1 - BH011
(Interchangeable)

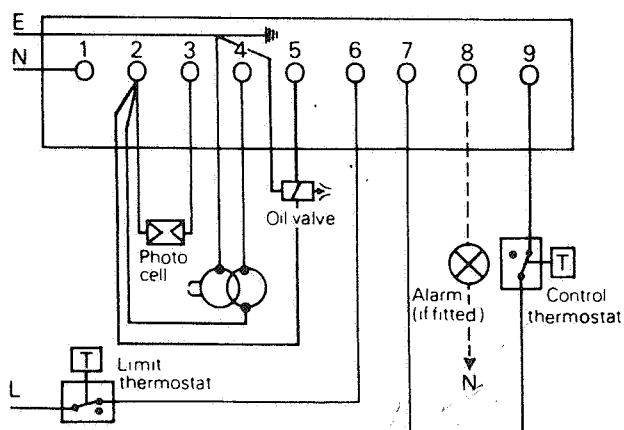

Satronic TF701B

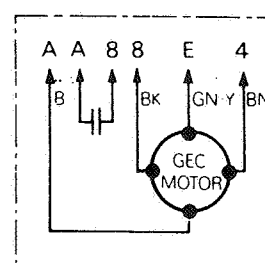
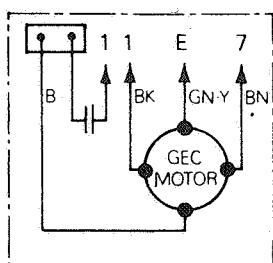
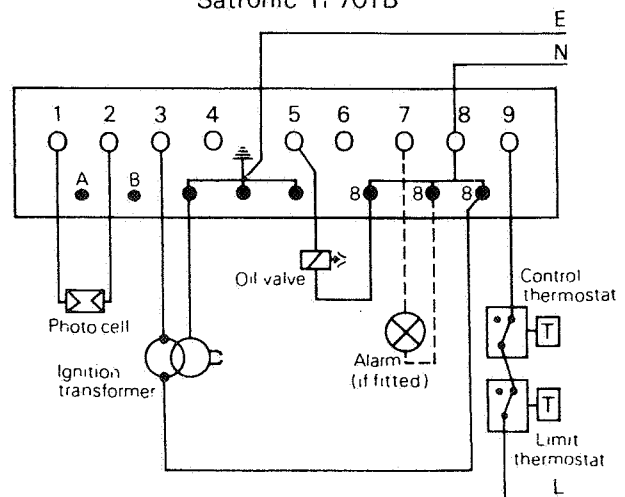

Motor starts but burner will not light. If the flame is not established the burner will be stopped and 'locked out' after a safety period of 15 seconds: the warning light is illuminated on the sequence control box. The manual reset button, also mounted on the sequence controller, should not be operated until at least 30 seconds after the burner has been 'locked out'.

Ascertain whether oil is being sprayed by the nozzle.

If oil is passing through nozzle, check that there is a spark at the electrodes. Check all connections including high voltage leads.

Check electrode gap and correct if necessary.

Ensure that electrodes are not short circuited and that their insulators are not cracked.

If there is no oil spray check that there is an oil supply to the burner and that all valves are open. Check that nozzle is not blocked. Ensure that all filters are able to pass oil. Check that the pump solenoid is operative. Check that fuel pressure delivered by the pump is correct.

Unstable pump pressure. Check that the pump has been correctly primed by disconnecting return pipe from pump (on two-pipe systems); air-free fuel should flow out when the pump is run. On single pipe systems loosen the vent plug to ascertain that air-free oil flows out.

On installations where the burner pump has to lift fuel from the tank check that all pipework and connections on the suction side are free of leaks and that there are no blockages.

Burner fires then stops after a short time. Check that photo-cell is clean and correctly located. Check air damper setting and readjust as necessary.

Flame unstable, burner stops. Check for fuel supply fault, eg partial blockage of fuel supply pipe. Check nozzle atomisation, etc.

Burner stops after satisfactory running period. If flame fails during normal running period, the ignition will be switched on again. If the flame is not re-established after a period the burner is stopped and 'locked out', and a warning (lock out) light illuminated on the sequence control box.

If the flame is re-established during this period the ignition is switched off and the burner will continue to operate normally.

MAINTENANCE

Before carrying out any work on the burner ensure that the electricity is switched OFF, and isolate oil supply.

Filters. A filter is fitted within the pump. To gain access remove pump end-plate (2 screws) and undo 2 cap head screws.

Withdraw filter and clean it in paraffin, or other solvent, using a stiff brush.

Replace filter and pump end-plate.

A filter should also be fitted in the fuel supply pipe. If fitted with a disposable element this should be replaced at least once per year, the frequency depending on the needs of the installation and the cleanliness of the fuel.

If the filter has a cleanable element this should be cleaned, at suitable intervals, in exactly the same way as has been described for the pump filter.

Motor. The motor requires no maintenance: it has bearings which are factory lubricated for the life of the motor.

Fan. If fan is damaged or becomes loose on the motor shaft the motor must be removed (4 screws) from the burner casing. Correct position of fan is such that a 3 mm gap exists between the end of the scoop and the inside of the fan backplate (motor side).

Solenoid valve coil. This is integral within the pump, access being gained by removal of two screws (see pump detail).

Landis & Gyr LAB1-LAI 4
(Interchangeable)

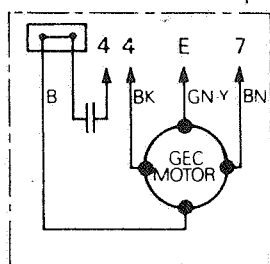
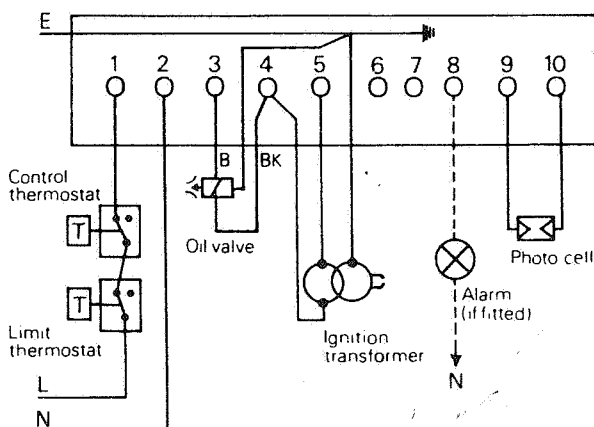

NU-WAY

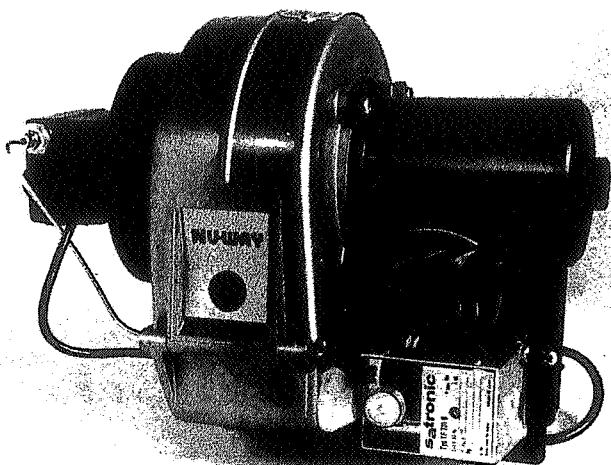

General view of the burner. On extreme left is the pump containing the integral solenoid. Top right hand is the motor with the control box beneath and transformer to the rear.

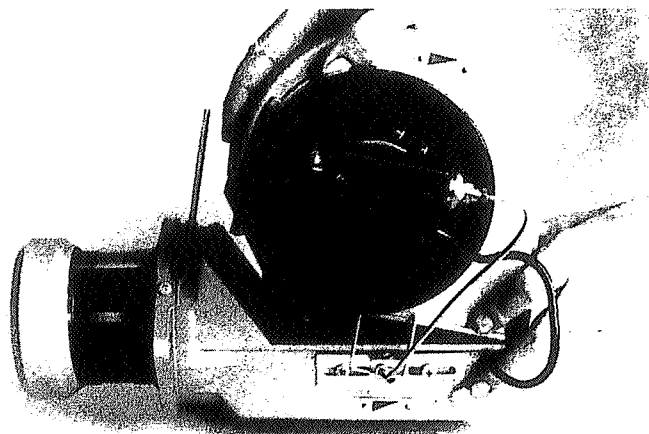

To hinge open the burner casing, FIRST disconnect oil feed pipe from union which then releases retaining catch. Then undo locknut from stud at front of casing and gently hinge open.

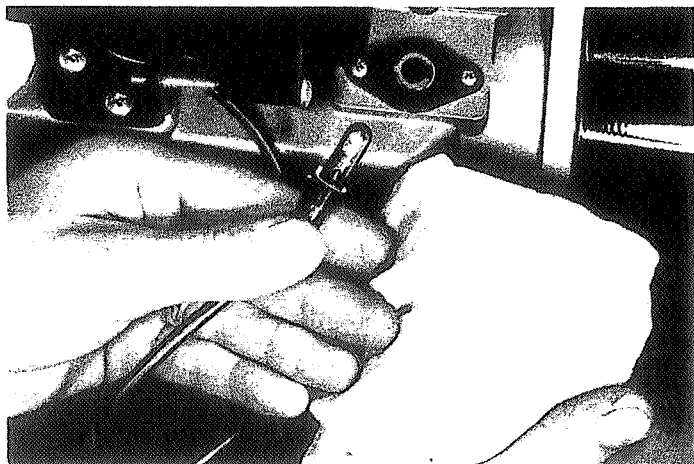
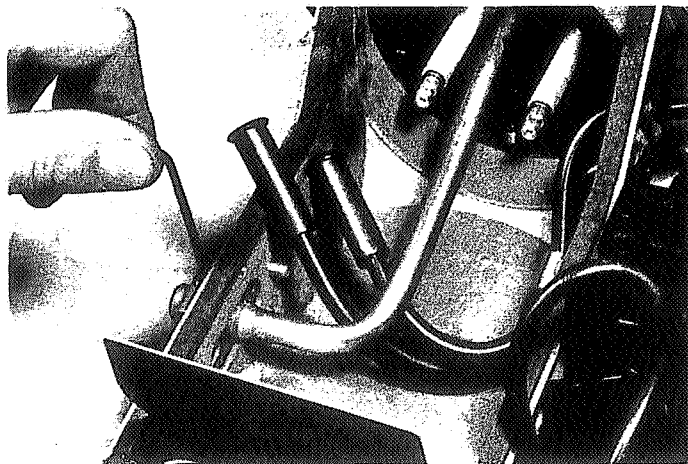
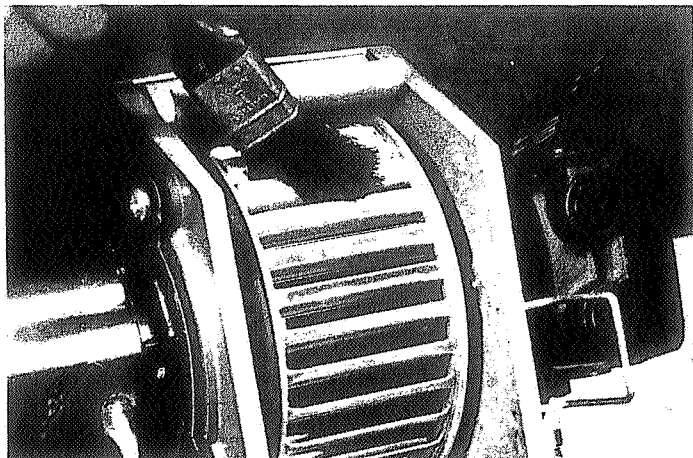

Photo-cell is removed from burner for cleaning. Do not touch cell with the fingers: use only a clean, dry cloth for cleaning. Ensure viewing head points towards flame position when replacing.



Before attempting to remove inner assembly, withdraw photo-cell from its housing. Assembly is removed by releasing retaining grub screw, disconnecting H.T. leads to electrodes, and gently withdraw.



Cleaning the fan runner: use a stiff brush.

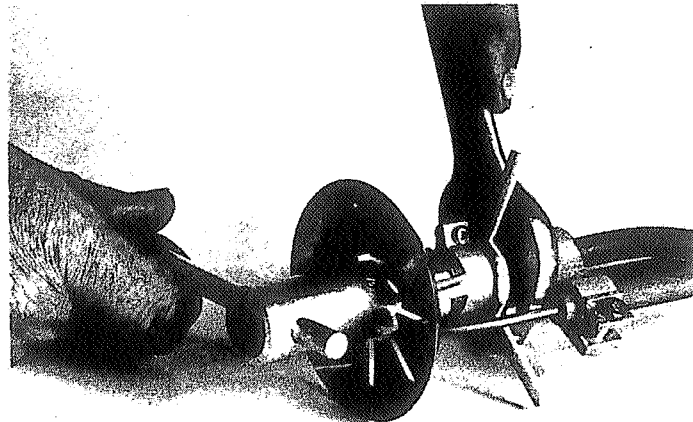

Nozzle is removed from inner assembly using a tube spanner. Take care not to damage diffuser or alter electrode setting. Fit nozzle to

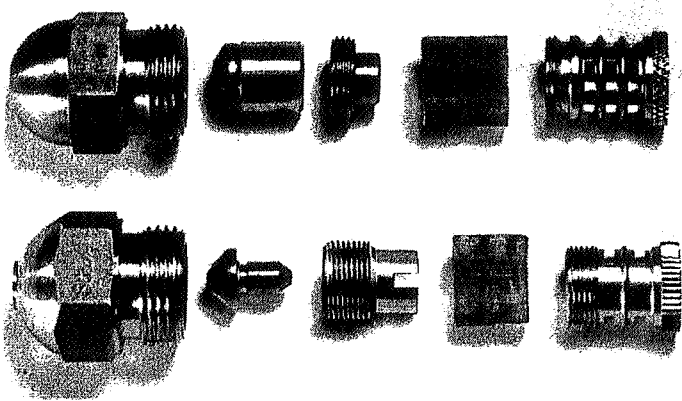

Dismantle nozzle itself to enable internal filter to be cleaned. Do not use any metal or wood to remove deposits. Wash in solvent. Wipe off any remaining dust using a clean, lint-free rag. Illustration shows correct assembly sequence for (above) Monarch and (below) Steinen nozzles. Replace after 2000 operations or 1 normal heating season.

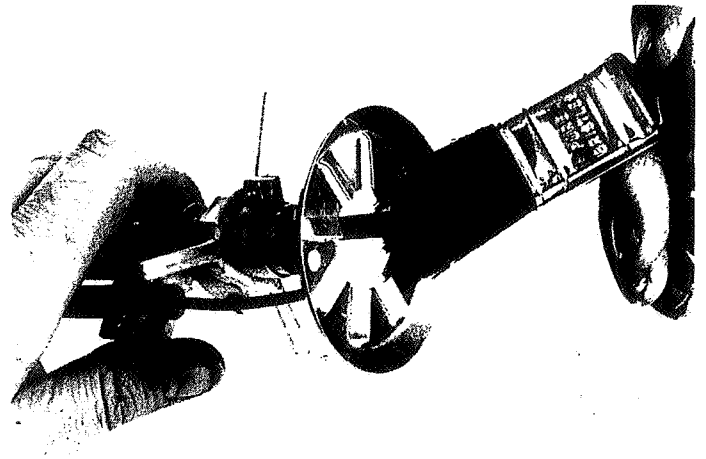

Air diffuser should be cleaned using a stiff brush.

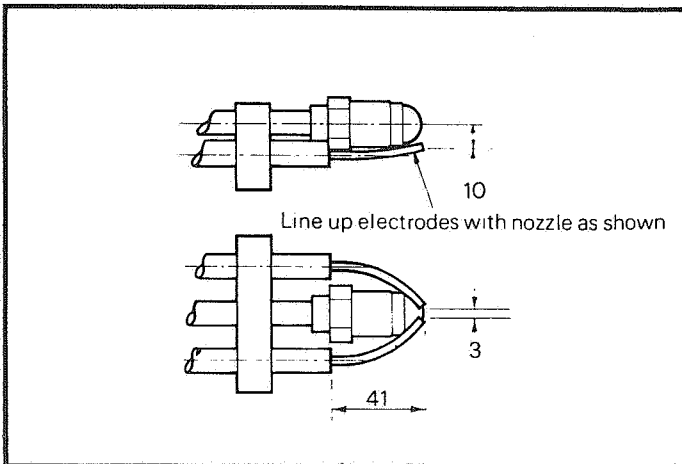

Electrodes should be set to these dimensions to ensure trouble free ignition. Dimensions are in millimetres.

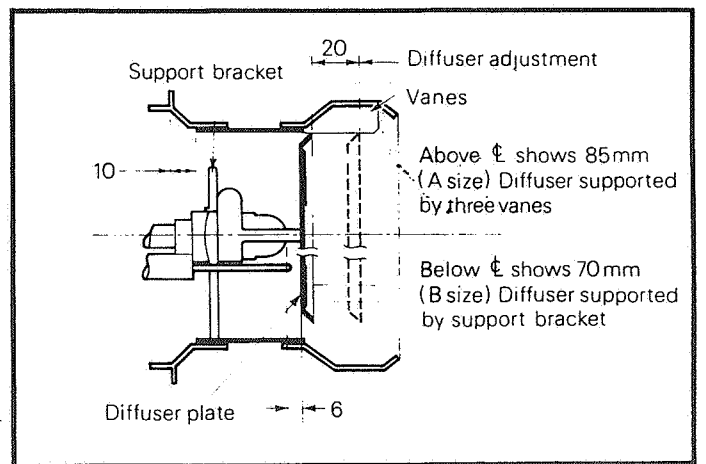

Adjustable head arrangement for both C2A and C2B burners.

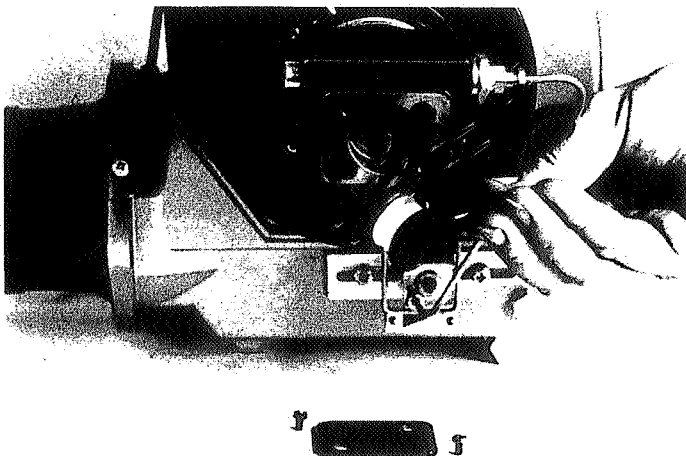

To detach solenoid coil from the pump, detach end-plate (two screwdriver head screws) and lift coil clear



Set rotary air damper by undoing screw and turning circular damper section to required position (see pre-firing check)

NU-WAY

SERVICE CENTRES

DROITWICH

Vines Lane, Droitwich WR9 8NA.
Tel: (09057) 2331 & 2527

PURLEY

102, Brighton Road, Purley, Surrey.
Tel: 01-668 2231

MANCHESTER

203, London Road, Hazel Grove,
Stockport SK7 4HJ.
Tel: 061-483 1207

WALTHAMSTOW

148, Wadham Road, London E17.
Tel: 01-531 3537

BELFAST

13, North Howard Street, Belfast
BT13 2AJ.
Tel: 0232 26127

BRISTOL

20, Kellaway Avenue, Bristol
BS 67 XR.
Tel: 0272 49229

GLASGOW

7, Park Circus Place, Glasgow
G3 6AH.

Tel: 041-332 2552

NEWCASTLE-UPON-TYNE

19, Lansdowne Terrace, Gosforth,
Newcastle-upon-Tyne. NE3 1HP
Tel: 0632 859223

DUBLIN

Hevac Ltd., Lomond Avenue,
Fairview, Dublin 3.
Tel: Dublin 373796

SPARES

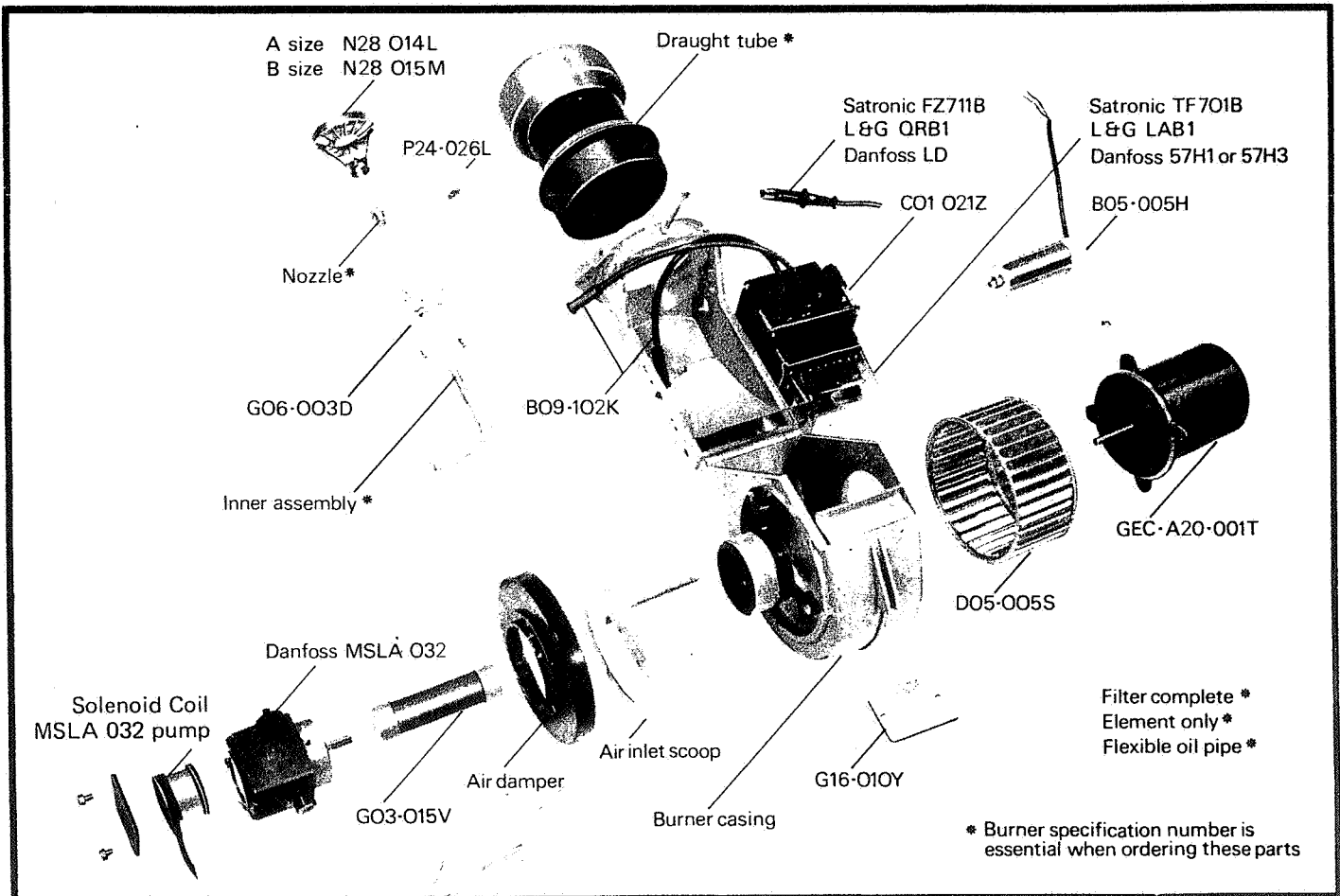

Nu-way Heating Plants Limited Droitwich, WR9 8NA, England

Telephone: Droitwich (09057) 2331 & 2527
Telex: 338551. Cables: JASNU DROITWICH

Nu-way policy is one of continuous improvement. The right to change prices and specifications without notice is reserved.



SAFETY

The burner must be operated and serviced in accordance with the procedures detailed within this handbook.