

## Installation & Maintenance Manual

### **Series NO fully automatic oil burner Models NOL & NOR 100, 125 & 150**

Oil Burner

## **CAPACITY**

The Nu-way NO pressure jet burner is designed for automatic operation with burner outputs from 1800-4400kW (1,600,000-3,700,000 kcal/h : 6,250,000-15,000,000 Btu/h). Available for high/low operation it is marketed to meet the requirements of all international markets.

The burner will fire pressurised systems having resistances as listed under burner selection, and also systems having a maximum draught of 0.125kPa (13 mm w.g. : 0.5 in w.g.) at full appliance rating.

## **AIR CONTROL**

Air controlled hydraulically operated on distillate fuel burners and electrically motorised for residual fuel burners. During shutdown periods this damper remains in the low flame position, although the pumping/heating system is still operating to keep the fuel at operating temperature.

Adjustable micro-switches controlling the fuel supply valves maybe set to introduce or cut off the oil supply at any position during the air damper movement. An air inlet silencer is fitted as standard.

## **CONTROLS**

The burner may be controlled by suitable thermostats, time switches, pressure thermostats etc. Burners are supplied complete with a pre-wired control panel. An additional separate panel is also supplied for steam boiler applications, this contains relays, feed water pump starter (direct on-line up to 4kW, star delta above), and built to steam boiler A.O.T.C requirements.

## **SAFETY FEATURES**

Flame supervision is by photoelectric cell with a sequence controller for automatic start up, running and shut down of the burner.

## **APPROXIMATE WEIGHT**

NOL type: 280 kg.

NOR type 318 kg.

## **EXTRAS**

Fully closing damper (NOL).

**FUEL**

NOL and NOR burners are suitable for use on distillate and residual fuels with viscosities as specified below.

NOL Models  
Class D 3 cSt at 37.8°C

NOR Models  
Class E. 8 cSt at 100°C  
Class F. 20 cSt at 100°C  
Class G. 40 cSt at 100°C

**NOTE**

The fuel to be used must be stated when ordering the burner.

**FUEL SYSTEM**

For distillate fuel (NOL), use single pipe gravity or two pipe suction lift systems.

For residual fuel (E & F) NOR use single pipe gravity feed or oil ring main systems.

For residual fuel (G) NOR a pre-heated, pressure regulated, ring main system must be used.

Three or four atomising nozzles, depending on model, for high/low operation.

Turndown ratio available, up to a maximum of 3:1.

A replaceable element filter for distillate oil is supplied and an edge type filtration fuel filter is supplied with cleanable element for residual oils.

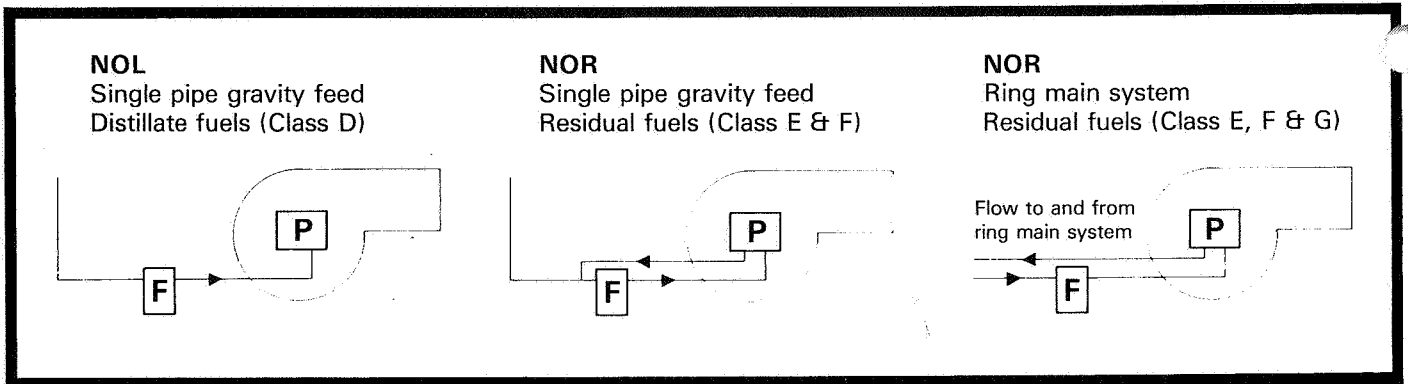
Fuel connections, filter inlet connection, 3/4 BSP female. (Fuel line to be correctly sized to suit application.)

Burners using residual fuels incorporate a factory set oil pre-heater unit. Minimum oil temperature at burner inlet:

16°C for Class E  
54°C for Class F  
83°C for Class G

**REDWOOD No.1 IS NO LONGER RECOGNISED.**

(Amendment to BS 2869)



**ELECTRICAL DATA**

Burner Model	Motors				NOL BURNER WITHOUT PRE-HEATER				NOR BURNER WITH PRE-HEATER				
	Fan kW	Fan hp	Pump kW	Pump hp	Start current A/phase	Run current A/phase	Cable size (mm <sup>2</sup> )	HRC fuse (A)	Pre-heater (kW)	Start current A/phase	Run current A/phase	Cable size (mm <sup>2</sup> )	HRC fuse (A)
NO100-41	11.0	15	0.75	1	72	22.8	6	30	7.5	82.5	33.3	16	50
NO100-44	11.0	15	0.75	1	72	22.8	6	30	7.5	82.5	33.3	16	50
NO125-36	7.5	10	0.75	1	57	15.6	4	25	9.0	69.5	28.1	10	40
NO125-41	11.0	15	0.75	1	72	22.8	6	30	9.0	84.5	35.3	10	40
NO125-44	11.0	15	0.75	1	72	22.8	6	30	9.0	84.5	35.3	10	40
NO150-36	11.0	15	0.75	1	72	22.8	6	30	12.0	88.7	39.5	16	60
NO150-41	11.0	15	0.75	1	72	22.8	6	30	12.0	88.7	39.5	16	60
NO150-44	15.0	20	0.75	1	92	29.7	10	40	12.0	100	46.5	16	60

All data calculated at 415 volts. All motors are 2-pole, 2800 rpm.

NOTE: Pump motor capacities (hp-kW) may change to suit pump selected.

## SPECIFICATION CHANGES

---

# NEW WIRING COLOURS

---

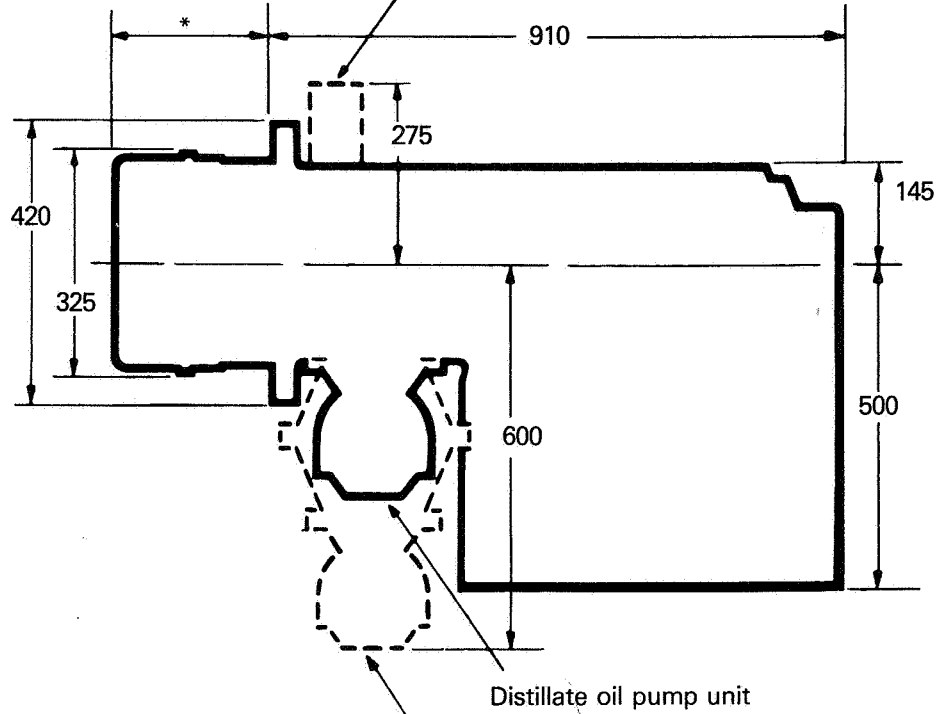
In accordance with the Requirements for Electrical Installations BS 7671:2001 Amendment No 2 (the IEE wiring regulations), wiring colour coding has been amended to Brown (L) and Blue (N) for single phase power circuits and Brown (L1) Black (L2) and Grey (L3) and Blue (N) **in three phase power circuits** from 1 June 2006.

Full details of the changes can be found in Amendment No 2 (AMD 14905) to BS 7671:2001 - which is a free download from the IEE website ([www.iee.org/cablecolours](http://www.iee.org/cablecolours)). They are also within the new version of BS7671:2001 (Incorporating Amds 1& 2) published on 31<sup>st</sup> March; this new version of the Wiring Regulations can be identified by its brown cover.

**LEADING DIMENSIONS**

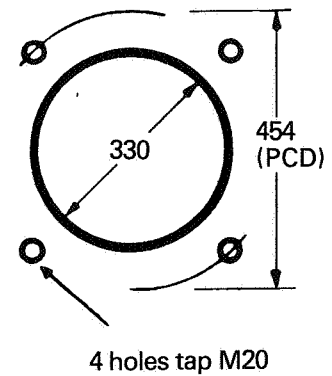
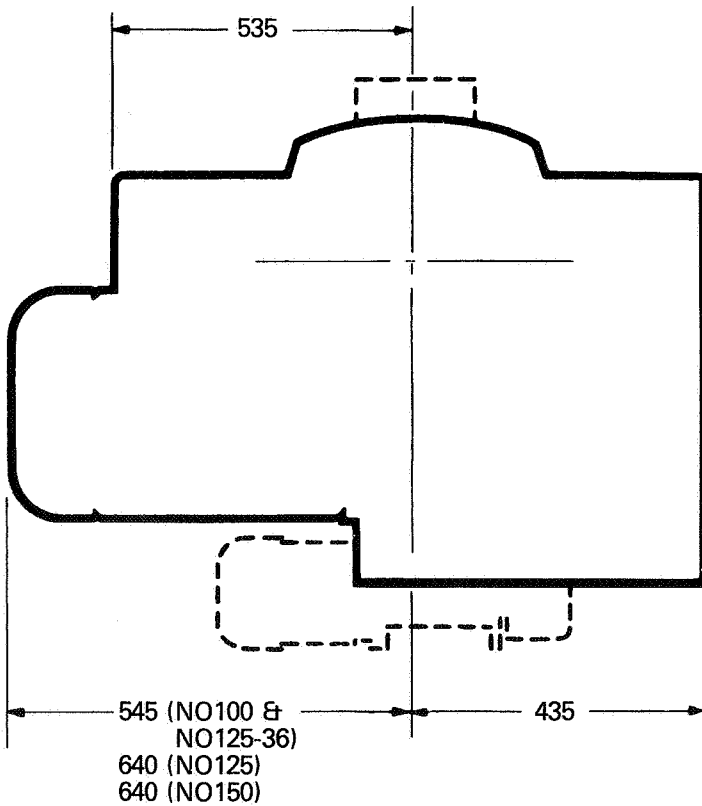
\* Standard projections  
240, 340, 430

Cover over nozzle cut-off  
solenoids, residual fuel only



Distillate oil pump unit

Residual oil pumping  
& heating unit



These dimensions are intended for general assessment of the overall sizes of the burners and should not be used without reference to our engineering department for inclusion in drawings for installation purposes. Certified dimensional drawings are available on receipt of orders.

## INTRODUCTION

The NOL and NOR100, 125, 150 oil burners are designed for automatic high/low operation and are available with burner outputs from 6.25 to 15 million Btu/h (1.8–4.4 mW/1.6–3.7 million kcal/h). The casing can accommodate three sizes of fan impeller. Appliances may have a resistance of up to 190 mm Wg/7.5" Wg, depending on output.

The burner is of monobloc construction to metric dimensions using fasteners to ISO metric standards.

A silencer is fitted, as standard, over the rotary air damper which is hydraulically actuated with light fuel and is electrically driven on burners for heavy fuels.

## FUEL

The burners are suitable for Classes 'D', 'E', 'F' and 'G' fuels to BS.2869: 1970. For Class 'D' fuel, use a single pipe gravity, ring main or two pipe suction lift oil supply system.

**For Class 'G' fuel a pre-heated, pressure regulating ring main system must be used.**

A fuel filter with cleanable, edge type element is supplied with each burner.

Fuel connections are 3/4" BSP female.

### Oil Temperature for Residual Fuels

Fuel Class BS. 2869 1970	Viscosity Nominal cSt @ °C	Minimum Storage Temperature		Temperature required at Burner Unit		Atomising Oil Temperature	
		°C	°F	°C	°F	°C	°F
E	8	10	50	16	60	82	180
F	20	25	77	43	110	104	220
G	40	40	104	83	180	132	270

## CONTROLS

The burner may be controlled by suitable thermostats, pressure time switches, frost stats, etc.

Burners are supplied complete with a pre-wired control panel for hot water operation. For steam application a larger panel is fitted to house relays, boiler feed pump motor starter (to a maximum boiler feed pump motor rating of 4kW (5½ hp direct on line) etc., to AOTC requirements. For boiler feed pumps driven by larger DOL motors or for star/delta starting an AOTC panel is supplied as a unit separate from the hot water control panel.

## SAFETY FEATURES

Flame supervision is by photo-electric cell with sequence controller in conjunction with air pressure switch to prove there is an 'air flow' before allowing oil pump to start. (Pump driven with separate motor.)

## AIR PRESSURE SWITCH

The air pressure switch is required to prove that there is adequate flow through the burner during the pre-purge, ignition and operating cycle.

Air flow failure at any time during the pre-purge, ignition and operation of the burner will result in a safety shutdown.

## INSTALLATION

### MODELS NOL LIGHT OIL

The oil system operates at constant pressure and utilises more than two nozzles in order to minimise nozzle size, thus producing the fine atomisation necessary for efficient combustion.

NOL100 burners have only one nozzle for low flame operation: two further nozzles are also active on high flame. NOL125 and NOL150 have two low flame nozzles and two further nozzles which are used on high flame.

The turndown ratio attainable depends on individual application but is usually 3:1 on steam and 2:1 on hot water boilers. High flame total nozzle size divided by low flame total nozzle size gives the turndown ratio,

The air regulator is of rotary 'hit and miss' type and is hydraulically actuated. Access by removing top cover from silencer box and air adjustments by set pins operating against stop on moveable part of regulator.

An adjustable microswitch is actuated by the moving air regulator. The microswitch controls the air/oil phasing on the change from low to high flame. The switch also proves that the air regulator is moving before high flame is allowed to spray. The microswitch controls an additional, normally open solenoid valve.

The inner assembly, comprising the nozzle block and diffuser plate, can be removed through the burner casing. First, remove the burner casing top cover (eight screws).

Disconnect the two ignition leads from the tails of the electrodes.

Remove the Allen screw securing the outer manifold to the inner manifold, located on the right hand side of the burner casing. *Note that these two manifolds are sealed together by 'O' rings.*

The solenoid valves, pressure gauges etc., are now released from the outside of the burner casing. They may be supported, while the burner inner assembly is removed, by entering the Allen screw, through the outer manifold, into the (tapped) boss provided for the purpose in the burner casing immediately below the normal manifold location.

Remove the two nuts securing the inner manifold to the inside of the burner casing.

By grasping the inner assembly pipes the complete inner assembly/diffuser can be withdrawn from the casing.

The diffuser plate is mounted on a bracket clamped to the nozzle assembly.

The front of the nozzles should be set approximately 12 mm (½") behind the diffuser face.

The diffuser should be set 102 mm (4") back from the front of the flame tube. The position can be adjusted if necessary. If the burner has one low flame nozzle (the upper one) the ignition electrodes are set on this nozzle.

If there are two low flame nozzles the ignition electrodes should be set over the top left hand nozzle (as viewed from the front, or boiler side of the burner).

## PRE-FIRING CHECK

Check that the total nozzle size is correct for the particular application. The normal operating oil pressure of the burner is 20 atm. (20.7 bar: 300 lbf/in<sup>2</sup>). To obtain nozzle throughput in Imp gal/h multiply marking by 1.44. To obtain nozzle throughput in litres per hour multiply by 6.55 and for kg/h multiply by 6.2.

Check ignition electrodes and leads and the position of the nozzles relative to the face of the diffuser.

When replacing the inner assembly ensure that the 'O' rings are correctly in position between the union blocks.

Ensure that there is a good oil supply to the burner. Bleed one or two gallons from the flexible pipe to eliminate from the system any pipe scale and air. The oil pressure should be between 17.2 and 690 mbar (0.25–10 lbf/in<sup>2</sup>) and capable of satisfying the swept volume of the pump (545 l/h 1120 Imp gal/h).

### BEFORE CHECKING MOTOR ROTATION ELECTRICALLY, BLEED PUMP MANUALLY BY REMOVING THE RIGHT HAND ¼" BSP PLUG IN THE TOP OF THE PUMP UNTIL AIR-FREE OIL FLOWS.

The works setting of the air regulator is 6 mm (¼") open for low flame and 19 mm (¾") for high flame. The sequencing microswitch is set to bring in high flame oil after the air regulator has moved from 6 mm (¼") away from the low flame position. The air regulator is adjusted by means of set pins acting on a stop carried on the moving member of the regulator.

Access to the set pins and the sequencing microswitch is obtained by removal of the plate at the top of the silencer. Access to the air regulator is by removal of the silencer.

To remove:

- (1) Take off guard at inlet.
- (2) Remove two nuts securing silencer to casing accessible from underneath.
- (3) Take off two remaining nuts through top cover and remove silencer.

Check that all controls and flue dampers are correctly set.

Turn switch on control panel to 'low flame hold' and ensure that there is water in the boiler.

## FIRING

### LOW FLAME

Switch on electricity supply. If controls are correctly set, burner fan will start, followed by oil pump, providing air pressure switch changes over. Check rotation of each.

Air pressure switch is works set at 50 mm Wg, but may have to be adjusted to suit installation.

After pre-purge period has elapsed the low flame solenoid valve will open allowing oil to spray through the low flame nozzle only and be ignited by the HT spark which is already present.

The photo-electric (PE) cell should take over and burner will run.

At this stage adjust the air regulator to give a visibly clean flame.

Do not fire the burner for long periods until warming up of appliance is completed. During warm up check lockout period by 'blacking-out' PE cell while burner is firing: burner should stop within one second. Keep PE cell covered: after between 20 and 40 seconds burner should start its cycle again. It should lock out five seconds after the low flame solenoid valve is energised. The air regulator should now be set to give a CO<sub>2</sub> reading of 10–11% with a smoke number of 0–1.

### HIGH FLAME

When the appliance is ready to be fired at high flame, move switch on control panel to this position. The two high flame solenoid valves will be energised. The normally closed valve will open and allow pressurised oil to pass to the hydraulic cylinder actuating the air regulator. At the same time the other, normally open, high flame solenoid valve will close to prevent oil reaching the high flame nozzles until the air regulator has moved and actuated the sequencing microswitch. The microswitch controls this second high flame valve and should be adjusted to give a clean changeover from low to high flame.

With the burner operating on high flame adjust the air regulator to give a CO<sub>2</sub> reading of 12–13% and a smoke number of 0–1.

If silencer has been removed, refit and again check CO<sub>2</sub> and smoke readings, re-adjusting the air regulator if necessary.

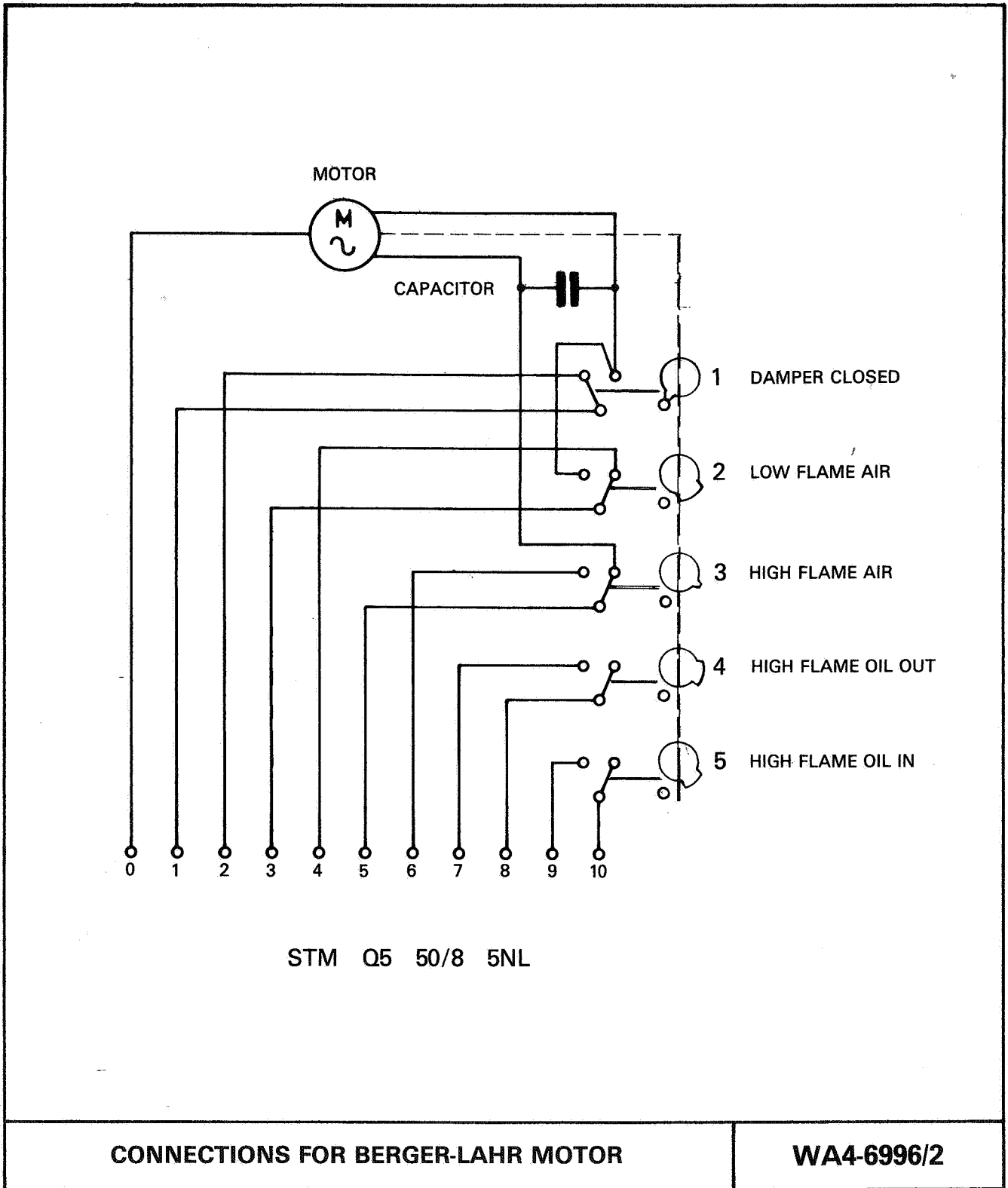
### MODELS NOR HEAVY OIL

Nu-Way type NO burners designed for operation of heavy or extra heavy oil and having designations of R (e.g. NOR100) have an oil system which consists essentially of a solenoid operated nozzle tip shut-off feature and employing a normally open solenoid valve and a pressure switch.

The complete nozzle assembly and diffuser plate is removable through the burner casing in a manner similar to that for the light oil models. To remove this assembly disconnect the quick release oil pipe couplings on the burner front top cover and the electrical plug and socket connection to the solenoids: this plug is located on the right hand side of the burner.

After removal of the burner rear top cover (six screws) the front top cover (four screws) may be removed complete with the nozzle cut-off assembly, diffuser and actuating solenoids.

The air regulator is driven by an electrical servo-motor housed, with its travel stops and sequencing cams, which is situated immediately above the air regulator.



**Instructions for 'Factory Setting' of Berger Motor, or Fitting of Replacement Motor**  
 Before motor is fitted to burner, cams to be set approximately as shown on WA4-7389.

**To Set**  
 Remove motor cover — rotate motor shaft (with special lever fitted) until flat is at top. Motor held as mounted on burner (conduit entry at top) this will be its closed position, indicating pointer will also be at T.D.C. All cams now to be adjusted and set, by rotating lever on shaft cams can be easily moved to facilitate settings.

**Berger LAHR Motor and Air Damper Position Indicators**

The Berger LAHR Motor is fitted with an Indicator, Illustration A (below): this is to facilitate the easy and correct setting of the various Cams Nos. 1 to 5. See also WA4-7389, this shows the setting and relationship of the five cams.

The Air Damper Spindle is also fitted with a pointer, and an indicator as illustrated in Illustration 'B'. This indicator is located at the rear of the Burner Air Inlet.

**IMPORTANT**  
 DO NOT adjust cams whilst Motor is rotating.



# FACTORY SETTING OF CAMS AND RELATED MICROSWITCH POSITIONS OF AIR DAMPER MOTOR TYPE BERGER-LAHR

ROTATION: OMNI-DIRECTIONAL

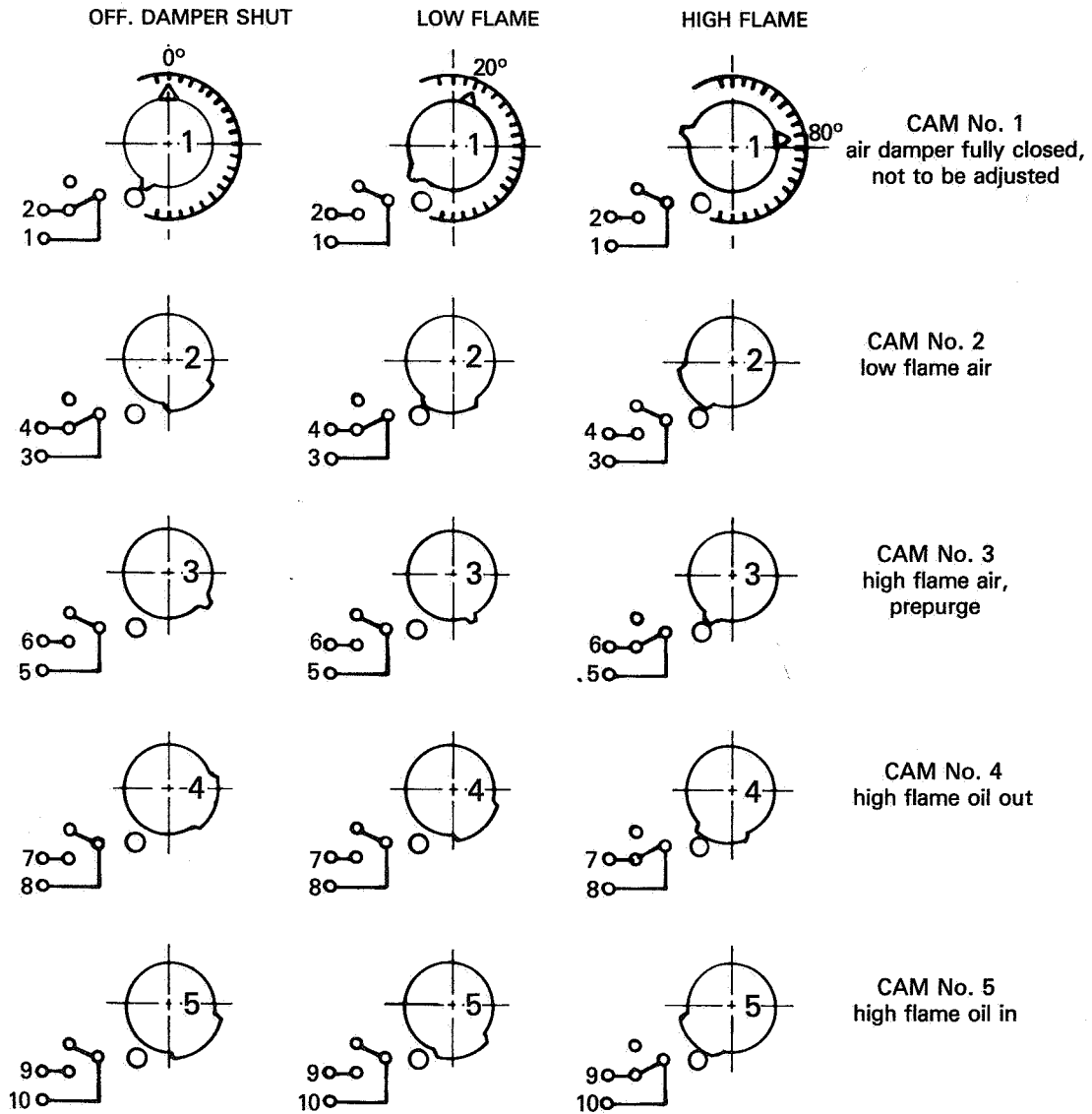
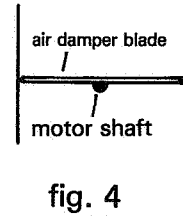
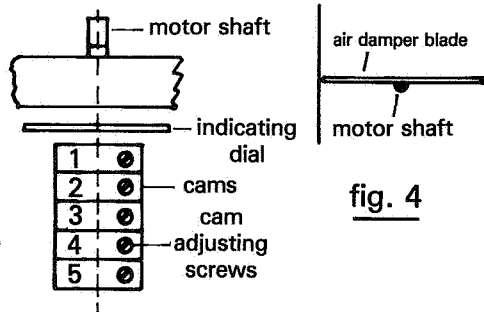
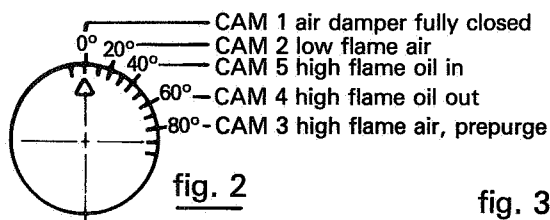


fig. 1



Cams are 'factory set' as per WA4-7389. Cams Nos. 2 and 5 will require adjusting when burner is installed on its appliance, to cater for the particular nozzle size, resistance etc. Re-check Cam No. 1 for fully closing.

The sequence provides for a 'closed' air damper position when the burner is in the 'off' position. This prevents cold air being drawn through the boiler and taking heat away wastefully up the chimney. (Alternative to this is to have a 'fully closing' damper fitted in exhaust system.)

### Sequence of Operation

On demand for heat, the motor will drive the air damper to high flame air setting for pre-purge of appliance by burner fan, and then returning air damper to low flame position for light-up. (Motor drives clockwise to high flame.)

When burner has ignited and there is a demand for high flame, motor will drive and start to open air damper and also via its cam/micro switch (No. 5) energise the three-way magnetic valve (which in turn hydraulically controls high flame air position (adjustable)). Cam No. 3 will stop motor at high flame air position. When high flame heat demand is satisfied (provided high/low sequence is being used), motor will drive air damper to low flame position, de-energising three-way magnetic valve (position again adjustable via Cam No. 4) which in turn closes the high flame nozzle. When heat demand is fully met, motor will drive air regulator to the closed position.

### To Adjust

No attempt should be made to adjust Cam No. 1, which controls the closed position, unless abnormal operating conditions warrant it, i.e. large amount of refractory in combustion chamber/top firing, etc., giving excess amount of 'back radiation' on to burner on shut down (see note on wiring diagram).

- (1) To increase low flame air, hold burner in low position with switch in panel, Cam No. 2 should be adjusted by turning adjusting screw with small screwdriver anti-clockwise slightly. Damper will not move until motor has driven some distance towards high flame position, this can easily be done by moving switch in panel to 'high' position and returning to low position, when damper will take up new setting.
- (2) To decrease low flame, again hold in 'low' position and turn adjusting screw in a clockwise direction, very slightly. Damper will close immediately.

It is very important to note the indicating pointer position before and after any adjustment, in order to make sure air damper has been adjusted the correct way.

- (3) High flame air. Factory setting is in the fully open position, therefore to decrease air turn Cam No. 3 anti-clockwise (panel switch in high position) move switch to low and return immediately to high, when air damper will reposition. To increase high flame air turn adjusting screw clockwise and damper will react. Never try to take high flame air setting more than the 90° fully open position.
- (4) Cam No. 4 facilitates 'phasing of air/fuel' and provides a 'high' flame oil 'in'. By adjusting this cam clockwise, the three-way magnetic valve which

indirectly controls high flame nozzle can be delayed or vice-versa by adjusting anti-clockwise.

- (5) Cam No. 5 phases high flame oil 'out' and adjustment is similar to Cam No. 4.

Finally recheck on all positions after adjustment (CO<sub>2</sub> readings etc.).

The pre-heater installed on the NOR burners is designed to raise the temperature of the oil by 50°C (90°F). At maximum burner rating. It is important to note the following temperatures which must be attained for efficient burner operation.

Fuel Class BS. 2869 1970	Viscosity Nominal cSt @ 100 °C	Minimum Storage Temperature		Temperature required at Burner Unit		Atomising Oil Temperature	
		°C	°F	°C	°F	°C	°F
E	8	10	50	16	60	82	180
F	20	25	77	43	110	104	220
G	40	40	104	83	180	132	270

The pre-heater installed on each burner has three thermostats; high limit and control instruments and a low temperature limit thermostat (reverse acting).

A pressure switch is provided to prevent energisation of the nozzle cut-off actuating solenoid until sufficient pressure exists for efficient atomisation. This switch is set to close at approximately 8.2 atm. 120 lbf/in<sup>2</sup> but it can be adjusted if necessary.

On all NOR burners a recirculation thermostat is installed in the return oil line: normally this instrument is set to 71° C (160°F). When the burner is operating with Class 'G' fuel 85 Kinematic (cS) the burner is usually left switched on at the main electrical isolator switch. Then on demand from the circulation thermostat the burner oil pump is started to circulate hot oil up to the nozzles thus keeping the pipework warm, this recirculation is not necessary with 12.5 Kinematic (cS) and only under certain conditions with 30 Kinematic (cS) i.e. very cold conditions.

### PRE-FIRING CHECK

Check that the total nozzle size is correct for the particular application. The normal operating pressure of the burner is 20 atm (20.7 bar: 300 lbf/in<sup>2</sup>). To obtain nozzle throughput in Imp. gal/h multiply nozzle marking by 1.44. To obtain nozzle throughput in litres per hour by 6.55 as for kg/h multiply by 6.2.

Check ignition electrodes and leads and the position of the nozzles relative to the face of the diffuser.

Ensure that there is a good oil supply up to the burner. Bleed one or two gallons from the flexible pipe to eliminate from the system any pipe scale and air. The oil supply pressure should be between 17.2 and 690 mbar (0.25–10 lbf/in<sup>2</sup>) and capable of satisfying the swept volume of the pump (545 litres per hour 120 Imp. gal/h).

**BEFORE CHECKING MOTOR ROTATION ELECTRICALLY, BLEED PUMP MANUALLY BY REMOVING THE RIGHT HAND ¼" BSP PLUG IN THE TOP OF THE PUMP UNTIL AIR-FREE OIL FLOWS.**

Check that all controls and flue dampers are correctly set.

Turn switch on control panel to 'low flame hold' and ensure that there is water in the boiler.

Check that the pre-heater is full with oil by removing the oil filter situated on the top of the unit. Fill, if necessary, with clean oil through the filter opening.

Check that the pre-heater thermostats are set correctly for the grade of oil being used. Initial settings should be as follows:—

Fuel Grade Kinematic		Control Thermostat		High Limit Thermostat		Low Limit Thermostat	
		°C	°F	°C	°F	°C	°F
Class E	8 cS @ 100°C	82	180	110	230	66	150
Class F	20 cS @ 100°C	104	220	132	270	82	180
Class G	40 cS @ 100°C	127	260	149	300	104	220

Remove covers from silencer box at right hand side of burner to obtain access to the air regulator system. (If necessary to remove silencer complete as per light oil model.)

## FIRING

### LOW FLAME

Switch on electricity supply.

There is a delay of approximately 10 minutes before the normal burner starting sequence can begin. This delay is the period required by the pre-heater to raise the temperature of the oil to the atomising temperature. When this temperature has been reached the pre-heater low limit thermostat contacts close, thus completing the burner control circuit.

Providing all other controls are correctly set the burner will run through its normal starting cycle. The burner fan and pump motors will start and hot oil will be circulated up to the burner nozzles. (Again check rotation of both fan and pump motors.)

After approximately 30 seconds the normally open, main oil solenoid valve closes and oil pressure increases. When the pressure reaches about 8.2 atm (120 lbf/in<sup>2</sup>) the oil line pressure switch closes thus energising the solenoid actuating the low flame (right hand) nozzle cut-off.

Oil will now spray from the low flame nozzle(s) only and be ignited by the spark which is already present.

The photo-electric (PE) cell should now take over and the burner will run.

At this stage adjust the air regulator to give a visibly clean flame. Do not fire the burner for long periods until initial warming up of the appliance is completed. During warm up check the lockout period by blacking out the PE cell while the burner is firing: burner should stop within about one second. Keep PE cell covered: after 20-40 seconds burner should start its cycle again. It should lock out five seconds after the low flame solenoid is energised.

The air regulator should now be set to give a CO<sub>2</sub> reading of 10—11% with a smoke number of approximately 3 on the Bacharach scale.

## HIGH FLAME

After initial warming up of the appliance the burner can be switched to high flame by throwing the appropriate switch on the control panel. The servo-motor will start to drive the air regulator towards the high flame position. After it has moved a little distance the adjustable sequence cam will close the microswitch thus completing the circuit to the solenoid actuating the flame nozzle cut-off. Oil will now spray from the high flame nozzles and be ignited by the flame already present at the low flame nozzles. The air regulator continues to open until it reaches the high flame stop.

With the burner operating on high flame, adjust the air regulator to give a CO<sub>2</sub> reading of 12—13% with a smoke of approximately 3 on the Bacharach scale.

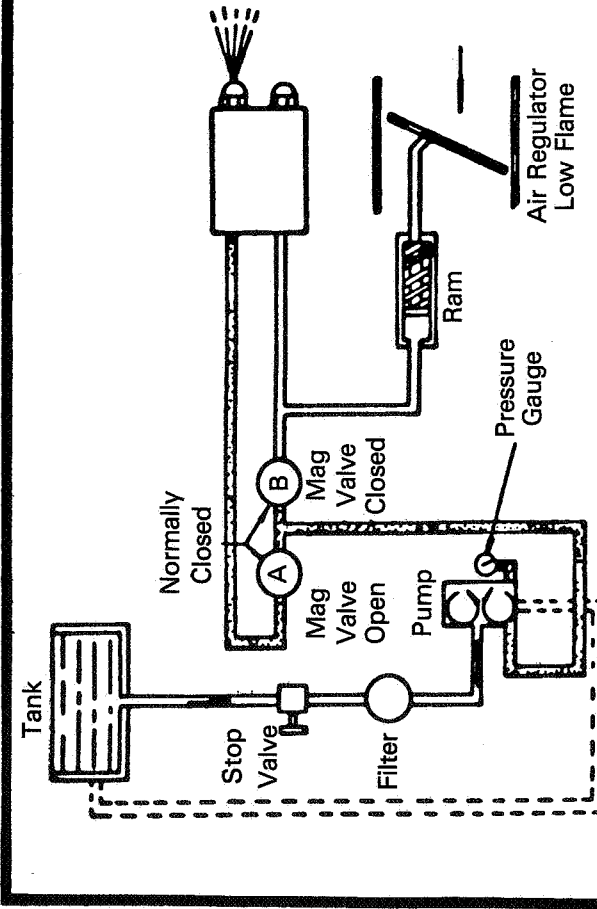
Adjust the sequence control cam and microswitch on the air regulator to give a clean and stable changeover from low to high flame and vice versa.

## FUEL:

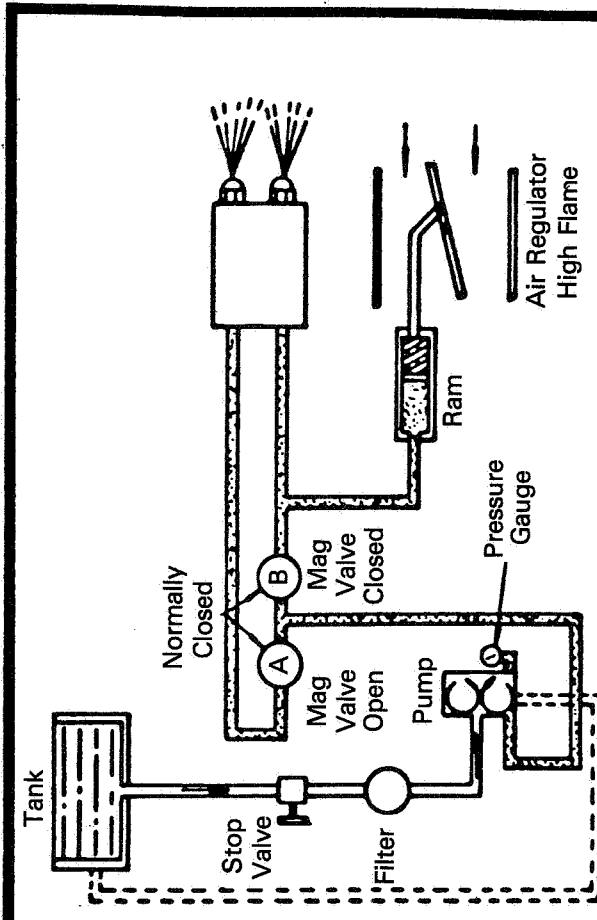
Kinematic Viscosity

- Class E. 8 cSt at 100°C
- Class F. 20 cSt at 100°C
- Class G. 40 cSt at 100°C

**OIL LINE SYSTEM NOL100, 125 & 150**

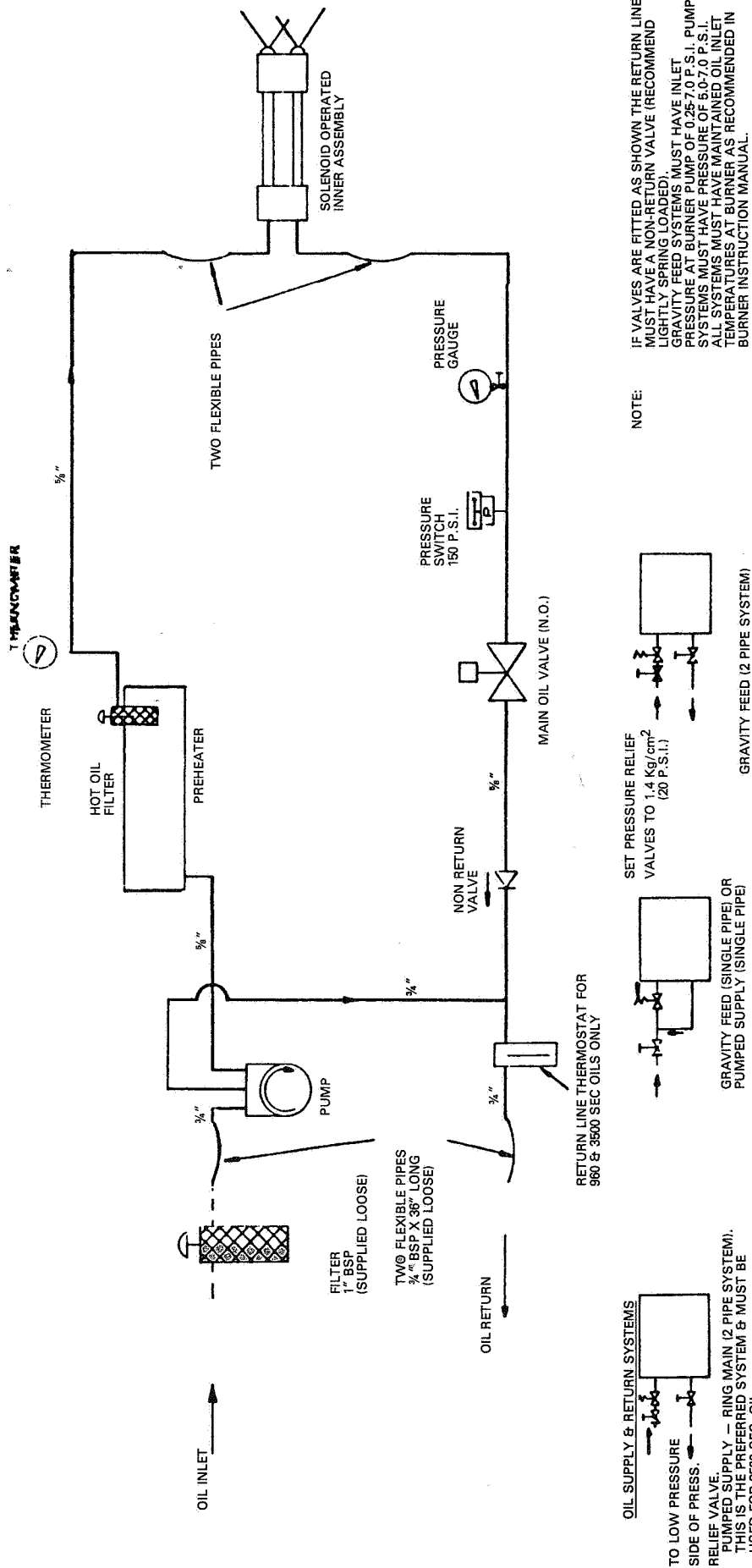


This line required on two pipe suction lift system  
(with pump installed to manufacturer's instructions)  
Low Flame (operating pressure = 300psi/21 bar)



This line required on two pipe suction lift system  
(with pump installed to manufacturer's instructions)  
High Flame (operating pressure = 300psi/21 bar)

# OIL LINE SYSTEM NOR100, 125 & 150



**OIL SUPPLY & RETURN SYSTEMS**

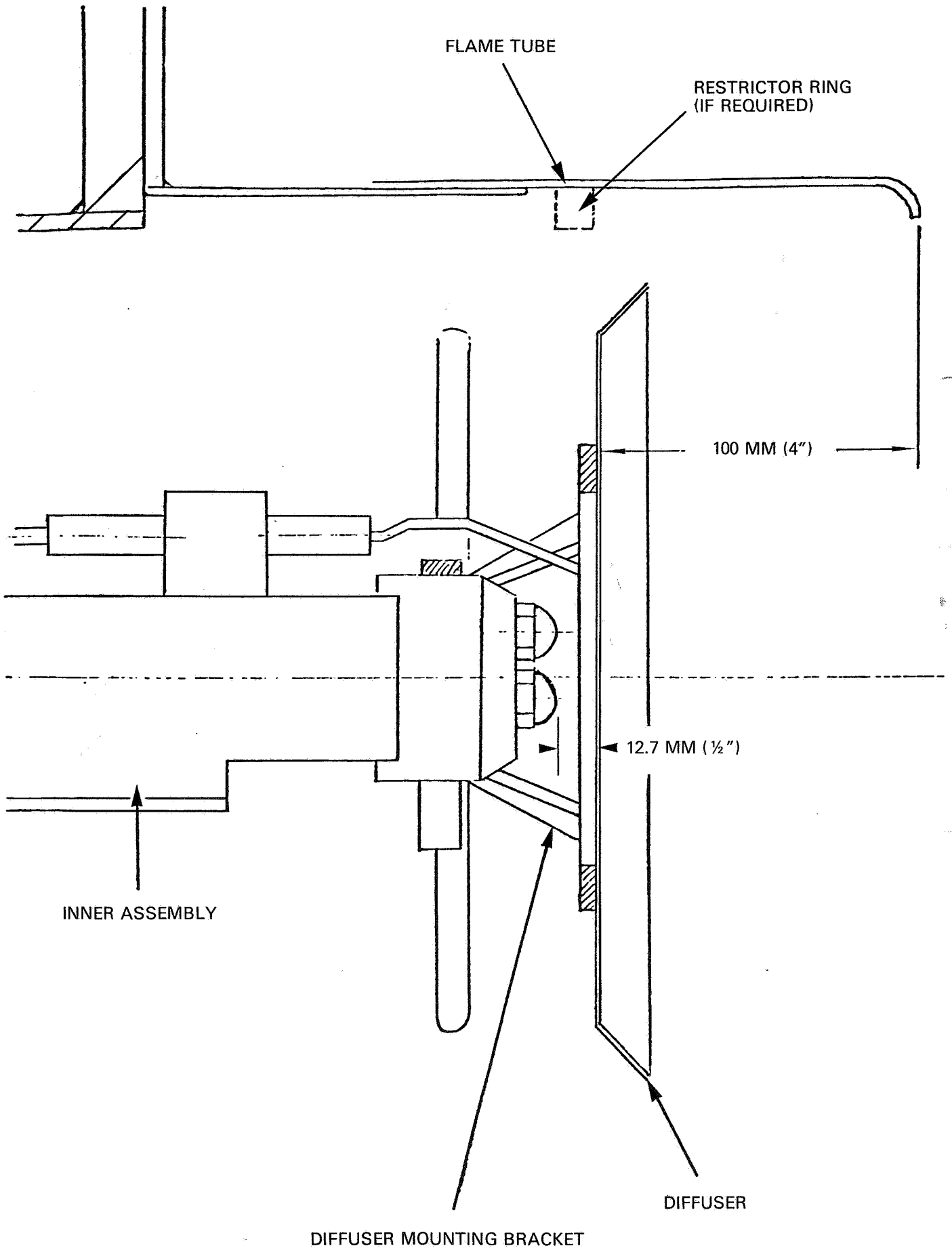
TO LOW PRESSURE SIDE OF PRESS. RELIEF VALVE.

GRAVITY FEED (SINGLE PIPE) OR PUMPED SUPPLY (SINGLE PIPE)

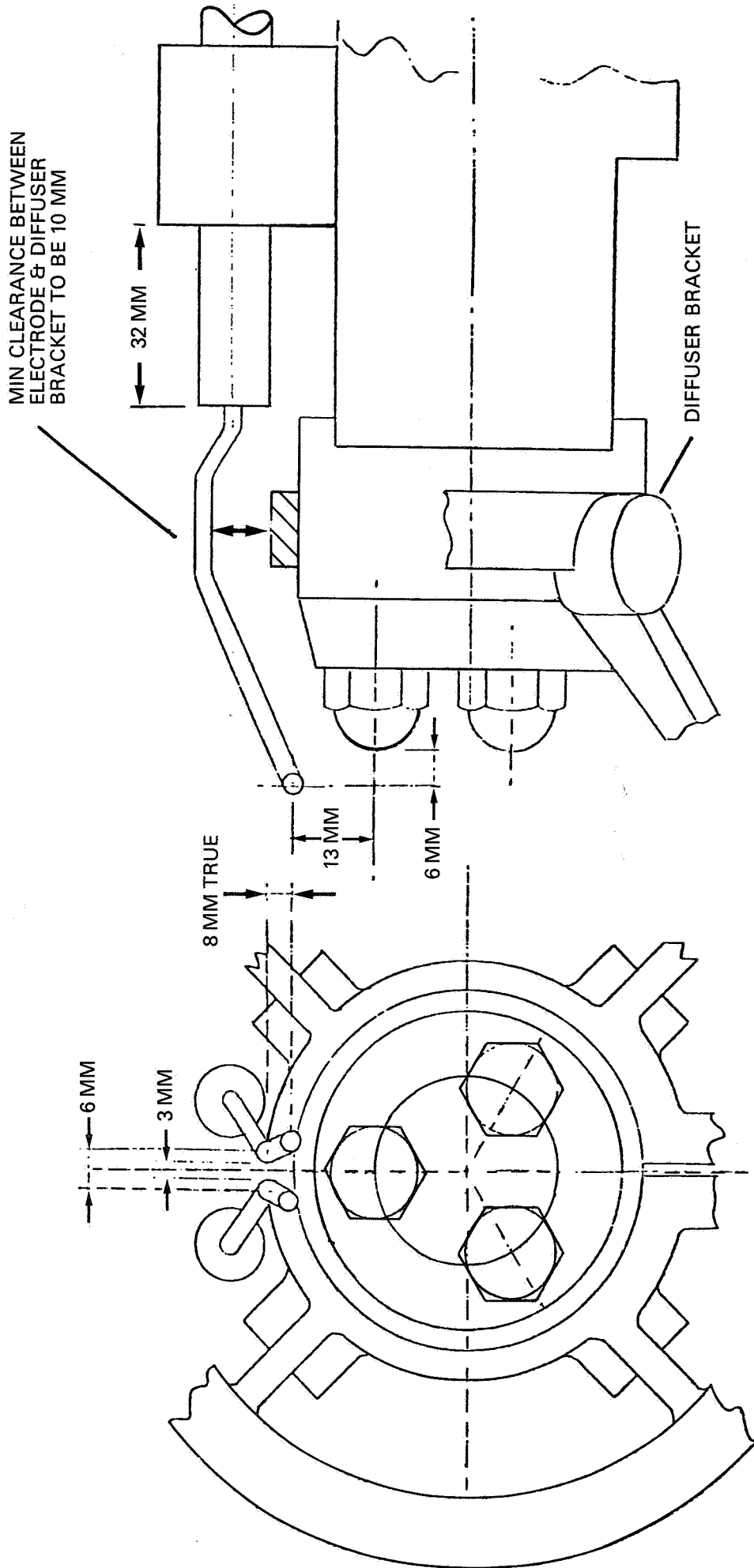
GRAVITY FEED (2 PIPE SYSTEM)

THIS IS THE PREFERRED SYSTEM & MUST BE USED FOR 3500 SEC. OIL.

**INNER ASSEMBLY FOR NO 100, 125 & 150**

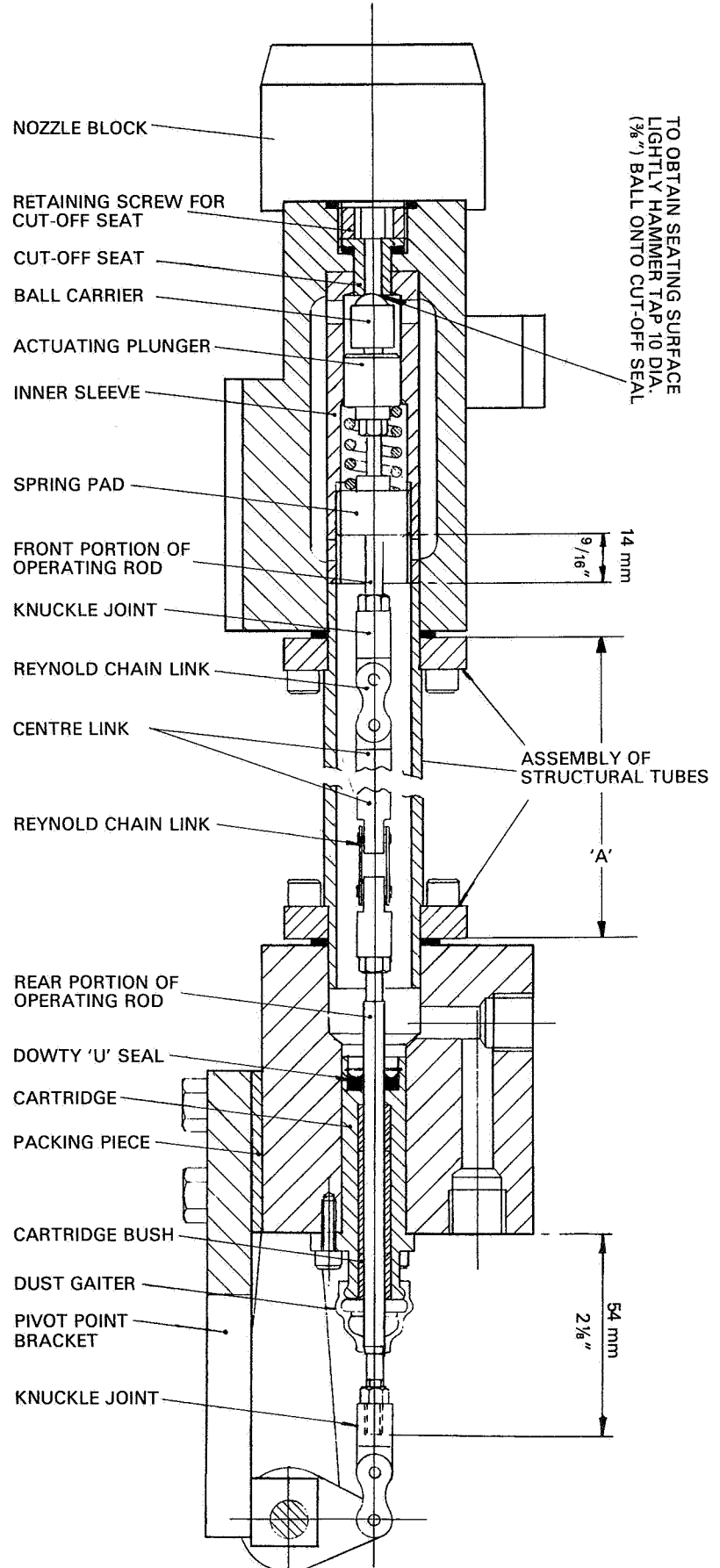


**ELECTRODE SETTINGS FOR NO 100, 125 & 150**



# INNER ASSEMBLY ARRANGEMENT FOR NO 100, 125 & 150

BURNER PROJECTION	LENGTH 'A'
210 mm	70 mm
240 mm	102 mm
285 mm	146 mm
335 mm	197 mm
380 mm	241 mm
430 mm	292 mm
480 mm	343 mm
535 mm	394 mm
762 mm	622 mm
686 mm	547 mm
240 mm	62 mm
430 mm	252 mm
610 mm	432 mm





## DANFOSS KSA FUEL PUMP

### INSTALLATION

The pump dataplate gives direction of rotation and connection port indication.

P = nozzle connection

S = suction line

R = return line

The pump is also fitted with two measuring ports, P<sub>n</sub> for nozzle pressure and P<sub>s</sub> for suction/feed pressure.

Ports P, P<sub>n</sub> and S, P<sub>s</sub> change position in groups depending on the direction of rotation.

Fig. 1 shows the respective connections for clockwise and counter-clockwise pumps.

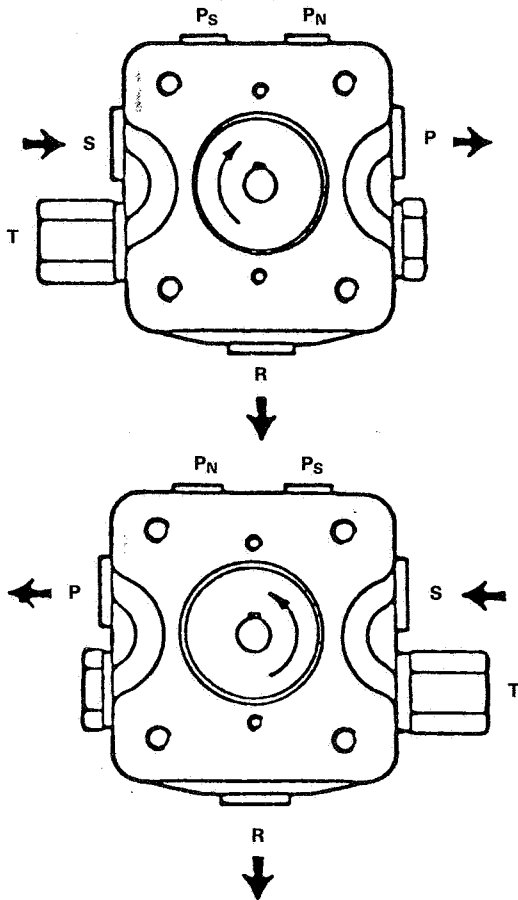


Fig. 1 Schematic Build-up

The hydraulic pressure regulating valve built into the pumps maintains constant pump pressure, but as the valve has no cut-off function the nozzle line must be fitted with an external cut-off valve.

The KSA series consists of pure 2-pipe pumps which must therefore always be connected to a return line. In 1-pipe systems with positive feed pressure the return line must take the form of an external bypass. See Fig.2.

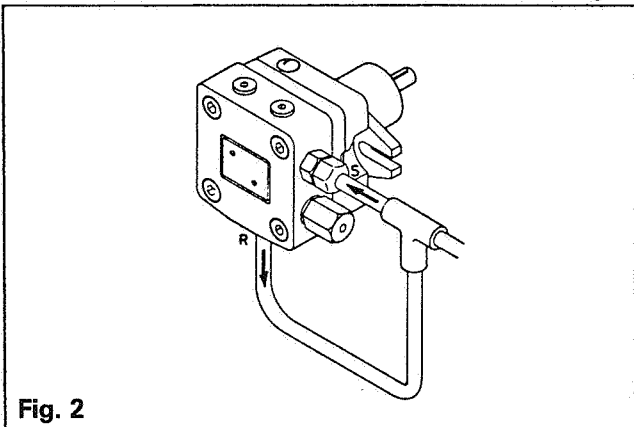


Fig. 2

When the pump is started, oil is sucked through pump suction port 'S' to the suction side 'C' of the gearwheel set (Fig. 3).

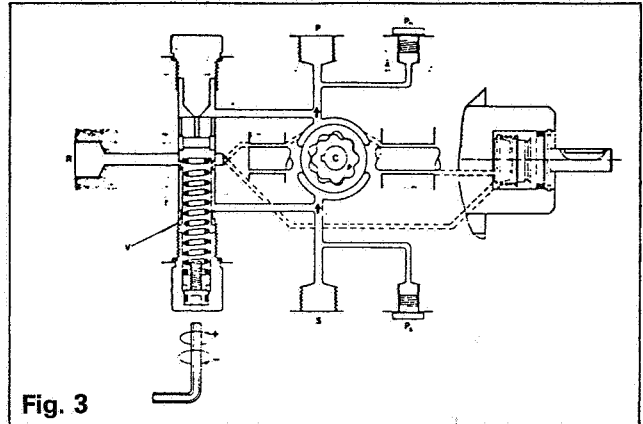


Fig. 3

From here the gearwheel set pumps oil to the pressure side while building pressure in the oil. This pressure is controlled and held constant at the pressure set on the regulating valve 'V'. The valve distributes oil supplied by the gearwheel set 'C' through port 'P' and pump return side 'R'. The quantity of oil deliveries is determined by the pressure on regulating valve 'V' and the oil nozzle/resistance in the nozzle line.

### INITIAL START

With oils under 20mm<sup>2</sup>/s KSA pumps are self-priming and self-venting in 2-pipe systems. During starting with cut-off nozzle line, venting is via the return line. During operation with open nozzle line, venting is partly via the nozzle and partly via the return line.

The installation must be equipped with prefilters, in accordance with current rules/practice.

When starting a light oil system with empty piping the KSA oil pump should not be allowed to run without oil for more than 5 minutes, assuming the pump contains oil before starting.

KSA pumps are supplied with pressure setting on minimum.

On light oil systems the regulating valve built into the pump must be adjusted to the required pressure when oil reaches the pump.

With heavy fuel oil the pump shaft must be turned slowly until hot oil reaches the nozzle outlet or the pressure measuring port. After burner start the pump must then be adjusted evenly up to the required pressure. The same method must be used after a stop when the oil has become partially or completely cold.

After this adjustment the pump will run under normal operating conditions.

If the pump becomes overloaded, i.e. more oil is demanded than the gearwheel set can deliver under the existing operating conditions, the oil pressure will fall under the set value because valve 'V' will close the return side 'R' and go to start position (Fig. 3). This condition can be remedied by:

- reducing the pump pressure,
- reducing the output, i.e. smaller oil nozzle or greater resistance,
- changing to a pump type with higher output.

## SUNTEC TA OIL PUMP

### OIL FLOW DIAGRAM

Oil entering the unit becomes trapped between the teeth of the involute gears and is expelled under pressure when the gears come back into mesh. An internal passage connects the pump outlet to the integral valve which regulates the oil pressure, dumping all oil excess to requirement to the return line if fitted, or on a 1 pipe system back to the pump inlet.

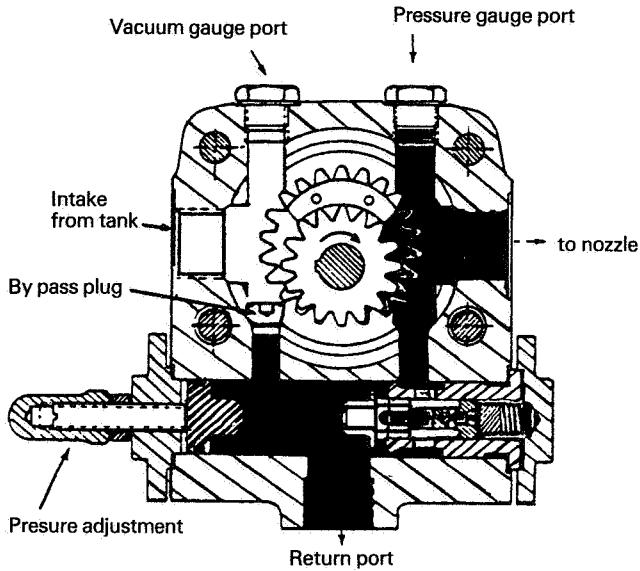


Fig. 4 Two pipe system

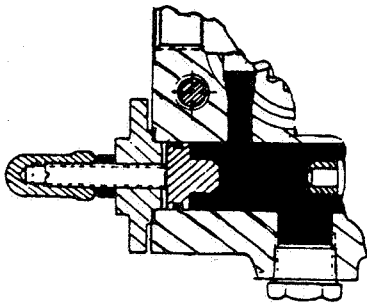
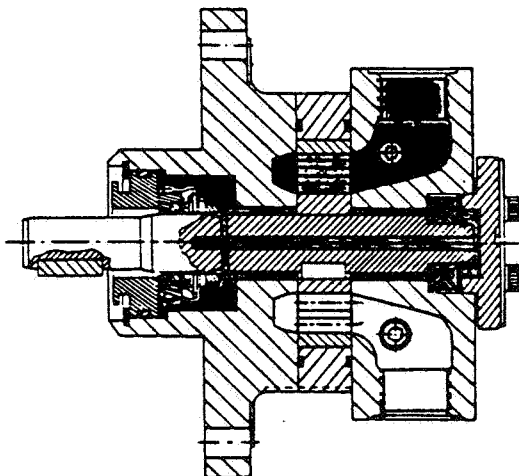


Fig. 5 One-pipe system



### TWO-PIPE SYSTEM (Fig. 4)

Check the presence of by-pass plug in vacuum gauge port. Connect the suction line to the inlet port, the return line to the return port, and the nozzle line to the nozzle outlet. Fill the pump with oil through the vacuum gauge port. Use pressure gauge port for air bleeding.

### ONE-PIPE SYSTEM (Fig. 5)

Remove by-pass plug from vacuum gauge port. Fit steel plug and gasket in return port. Connect the suction line to the suction port, and the nozzle line to the nozzle outlet. Fill the pump with oil through the vacuum gauge port. Use pressure gauge port for air bleeding.

### COMMISSIONING

Ensure that pump and inlet pipes are fully primed with warm oil. Oil starvation during start-up and normal operation may cause pump seizure.

### MOUNTING POSITIONS

TA pumps may be mounted in any position except with the shaft upwards.

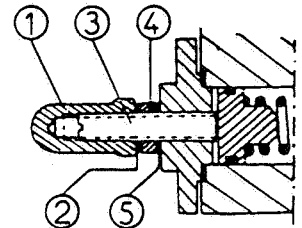
### PRESSURE ADJUSTMENT

Note: the maximum allowable pressure for model TA5 is 30 bar.

Remove cap-nut (1) and washer (2) unscrew lock-nut (4).

To increase pressure, turn adjusting screw (3) clockwise. To decrease pressure, turn screw anti-clockwise.

Block lock-nut (4), refasten washer (2) and cap-nut (1).

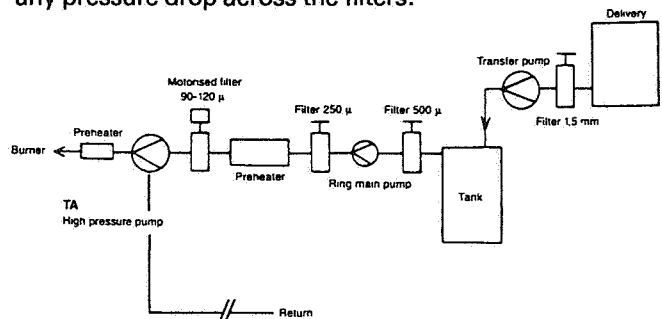


1. Cap-nut
2. Washer
3. Adjusting screw
4. Lock nut
5. Washer

### SPECIAL PRECAUTIONS FOR USE WITH HEAVY OIL

#### FILTRATION

When using heavy oil, the filtration of the oil is essential. The filtration system should be chosen according to the individual features of the installation. The diagram gives some basic guidelines. When checking the ring main pressure, this should be measured at the pump vacuum gauge port to allow for any pressure drop across the filters.



## LANDIS & GYR LAL OIL BURNER CONTROLS

### Application range

The burner control units type LAL are designed to provide control and supervision for atomizing oil burners of medium to high capacity. They are universally applicable for both multi-stage and modulating type burners.

---

For reasons of safety (self-testing of the flame supervision circuit, etc.) at least one controlled shutdown must be provided every 24 hours.

---

### OPERATION

The diagrams at the top show both the connection circuit and the control programme of the sequence switch 'P'.

The required resp. permissible input signals to the control circuit and to the flame supervision circuit 'F' are shown shaded. If these input signals have not been registered, the control unit stops the firing sequence, which is indicated by symbols, and goes to lockout where this is required by the safety regulations. The symbols used are identical to those on the lockout indicator.

- A Start command given by the control thermostat or pressurestat 'R'
- A-B Start-up sequence
- B-C Burner operation (heat generation according to the control commands given by the load controller 'LR')
- C Controlled shut-down by 'R'
- C-D Sequence switch runs through to its start position A

During burner-off periods the flame supervision circuit 'F' is under voltage.

#### Prerequisites for burner start-up

- Control unit reset
- Sequence switch in start position (with LAL1 indicated by voltage on terminals 4 and 11, resp. terminals 11 and 12 with LAL2 types.
- Air damper closed. The limit switch 'Z' for the CLOSED position must supply voltage from terminal 11 to terminal 8.
- The contact of the limit thermostat or pressurestat 'W' as well as the contacts of other switching devices contained in the control loop to terminal 5 must be closed (e.g. check-contacts for oil preheater).

#### Additional prerequisites with LAL2 types:

- Check-contacts between terminal 12 and the air pressure monitor 'LP' must be closed.
- The normally closed contact of the air pressure monitor 'LP' must be closed (LP test), i.e. terminal 4 must be under voltage.

#### Start-up sequence

- A Start command by 'R'

(i.e. 'R' closes the control loop between terminals 4 and 5).

The sequence switch starts to run and the fan motor receives voltage over terminal 6 (only pre-purge). After completion of t7 the motor of the flue gas ventilator also receives voltage over terminal 7 (pre- and post-purge). After completion of t16 the control command to open

the air damper is given via terminal 9. During the running time of the motor the sequence switch does not operate as terminal 8 is not under voltage during that time. The sequence switch starts again only after the air damper is fully open and the limit switch 'A' has changed over to supply voltage to terminal 8.

The control programmes now:

- t1 **Pre-purge time** with air damper fully open (nominal combustion air)

During the pre-purge time the safe functioning of the flame supervision circuit is tested (de-energizing of the flame relay). The control goes to lockout if the relay does not function.

With LAL2 types:

Shortly after the start of the pre-purge time the air pressure monitor must change over, thus disconnecting terminal 13 from terminal 4. Otherwise the control unit would go to lockout (start of air pressure check). At the same time terminal 14 must be under voltage to provide power for the ignition transformer and the fuel valves.

- t3'' **Long pre-ignition time** (transformer connected to terminal 15!)

With the LAL1 types the ignition transformer is switched on at the start command given by the thermostat or pressurestat 'R'. With LAL2, pre-ignition starts when the air pressure monitor closes the control loop between terminals 4 and 14.

After completion of the pre-purge time the control unit via terminal 10 runs the air damper to the low-flame position which is determined by the changeover point of the auxiliary switch 'M'. During the running time the sequence switch stops again until such time as terminal 8 receives voltage from 'M'. A short time later the motor of the sequence switch is switched over to the control section of the control unit. Therefore, control signals to terminal 8 have, from now on, no influence upon the further start-up of the burner (and the subsequent burner operation):

- t3 **Short pre-ignition time**, provided that the ignition transformer is connected to terminal 16; then release of fuel on terminal 18.

- t2 **Safety time**

On completion of the safety time a flame signal must be available at input 22 of the flame signal amplifier. Otherwise the control unit goes to lockout.

- t3n **Post-ignition time**, if the ignition transformer is connected to terminal 15. With short pre-ignition (connection to terminal 16) it remains switched on only up to the end of the safety time.

- t4 **Interval**. On completion of t4 terminal 19 is under voltage. This terminal serves for the voltage supply of the fuel valve at the auxiliary switch 'V' of the air damper motor.

- t4 **Interval**. On completion of t5 terminal 20 receives voltage and, simultaneously, control outputs 9 to 11 as well as input 8 are galvanically separated from the control section of the control unit so that the latter is protected against reverse voltages from the load control circuit.

The start-up sequence of the control unit ends with the release of the load controller 'LR' at terminal 20. The sequence switch switches itself off automatically, which takes place either immediately or after some so-called 'idle steps', i.e. steps without changing the contact positions.

## B Operating position of the burner

### B-C Burner operation (heat generation)

During burner operation the load controller runs the air damper to the nominal load or low-flame position, depending on the heat requirements. The release of the nominal load is achieved by the auxiliary switch 'V' in the damper motor.

With flame failure during operation the LAL types go to lockout. If, instead of this, **automatic repetition of the start-up sequence** is desired, a clearly marked wire link ('B') at the baseplate must be removed.

### C Controlled shut-down by 'R'

With controlled shut-down the fuel valves are closed immediately and, simultaneously, the sequence switch starts again and programmes

t6 **Post-purge time** (post purge with fan G2 at terminal 7).

Shortly after the start of the post-purge time the voltage at terminal 10 is reinstated, so that the air damper travels to the MIN position.

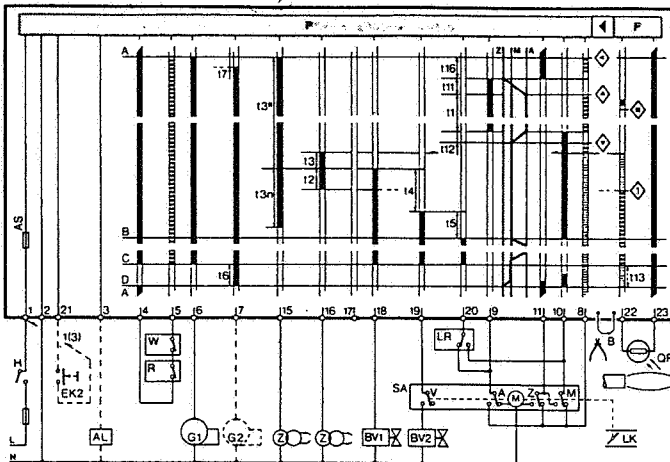
The complete closing of the air damper commences only shortly before the completion of the post-purge time, initiated by the control signal on terminal 11. Terminal 11 also remains under voltage during the following burner-off period.

t13 **Permissible after-burn time.** During this time the flame supervision circuit may still receive a flame signal without initiating burner lockout.

### D-A End of control programme ( = start position)

When, on completion of t6, the sequence switch has reset the control contacts to their start position, thereby switching itself off, the detector and flame simulation test starts again.

Voltage on terminal 4 (with LAL2 types: terminal 12) is the signal indicating that the start position has been reached.



Control signals of the control unit

Permissible input signals

Required input signals (if these signals are not received at the points marked by symbols or during the shaded phase, the control unit interrupts the start-up of the burner or goes to lockout).

### LAL1

A	Limit switch for OPEN position of air damper
AL	Remote lockout warning device (alarm)
AS	Unit fuse
B	Wire link
BV	Fuel valve
F	Flame supervision circuit
EK	Lockout reset button
G	Fan or burner motor
H	Mains isolator
L	Lockout warning lamp
LK	Air damper
LP	Air pressure monitor
LR	Load controller
M	Auxiliary switch for MIN position of air damper
P	Control section of control unit
QRB	Photoresistive detector
R	Control thermostat or pressurestat
RAR	Selenium photocell detector
S	Fuse
SA	Air damper motor
V	In the air damper motor: auxiliary switch for the release of fuel according to air damper position
W	Limit thermostat or pressurestat
Z	Ignition transformer
Z	In the air damper motor: limit switch for the CLOSED position

### CONTROL PROGRAMME UNDER FAULT CONDITION AND LOCKOUT INDICATION

In the event of fault conditions the sequence switch stops and simultaneously the lockout indicator. The symbol appearing above the reading mark indicates the kind of fault:

◀ **No start**, because, e.g. the CLOSE signal has not been supplied to terminal 8 by the limit switch 'Z' (or the auxiliary switch 'M'), or a contact has not been closed between terminals 12 and 4 or 4 and 5.

▲ **Shut down or start-up sequence**, because the OPEN signal has not been supplied to terminal 8 by the limit switch 'A'. Terminals 6 and 7 (with LAL1 types also terminal 15) remain under voltage until the fault is corrected.

■ **Lockout** due to a fault in the flame supervision circuit.

▼ **Shut-down of start-up sequence**, because the position signal for the low-flame position has not been supplied to terminal 8 by the auxiliary switch 'M'. Terminals 6, 7 and 15 remain under voltage until the fault is corrected.

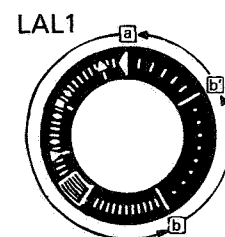
1 **Lockout**, because no flame signal has been received on completion of the safety time.

▮ **Lockout**, because the flame signal has been lost during burner operation or air pressure failure has occurred.

◀ **Lockout on completion or after completion or control programme sequence** due to extraneous light (e.g. flame not extinguished, leaking fuel valve) or due to a faulty flame signal (e.g. fault in flame supervision circuit or similar).

a - b  
Start-up sequence  
b - b'  
'idle steps' up to the self shut-down of the sequence switch

b(b') - a  
Post-purge sequence



When lockout occurs, the control can be reset immediately. After the resetting (and also after the correction of a fault which resulted in a controlled shut-down, or after each mains failure) the sequence switch always runs through to its start position, whereby only terminals 7, 9, 10 and 11 receive voltage in accordance with the control programme. It is only then that the control unit programmes a fresh burner start-up.

### ENGINEERING GUIDELINES

The installation of switches, fuse earthing etc. must be in compliance with the local safety regulations.

**If any adjustment on the controls is necessary, or any wiring change has to be made, the electrical supply to the control unit must be isolated before this work is undertaken!**

- 1 The phase and neutral connections may not be reversed!  
Max. permissible input current: 5A continuous, peaks of max. 20A (e.g. motor starting current)  
Safety limit thermostats (with hand reset, e.g. STB) are normally connected in the line.
- 2 Remote reset: When button 'EK2' is connected to terminal 3, only remote reset is possible; when it is connected to terminal 1, remote emergency shut-down is also possible.
- 3 Required switching capacity  
— contacts between terminals 4 and 5: 1 A
- 4 Check-contacts of other switching devices in the burner installation are to be connected (in series) as follows:

To terminal 4 or 5: Contacts which must be closed from start to the controlled shut-down (otherwise no start or controlled shut-down).

To terminal 12 of the LAL2 types: Contacts which must be closed only during the start phase (otherwise no start).

To terminal 14 of the LAL2 types: Contacts which must be closed latest at the start of the pre-ignition time and which must remain closed until a controlled shut-down (otherwise lockout): this is valid for both long and short pre-ignition.

Maximum loading of the control terminals 3, 6, 7, 9, 10, 11, 15 to 20: 4A each terminal, total maximum 5A: peak currents of max. 20A (e.g. starting current of G1 or G2).

'Z' to terminal 15: Long pre-ignition t3" and post ignition t3n.

'Z' to terminal 16: Short pre-ignition t3. The ignition transformer remains under voltage up to the end of the safety time t2.

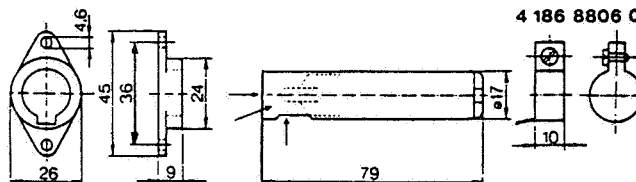
Connection of a fuel valve to terminal 20. See following notes and diagram.

Variants of the air damper control and guidelines for burners without air damper: see following notes and diagrams.

Wire link 'B': The burner controls go to lockout if flame failure occurs during operation; If, instead of this, repetition of the start-up sequence is desired, the clearly marked wire link 'B' at the baseplate must be removed (just cutting is not permitted).

### DESIGN OF THE LIGHT DETECTORS QRB

QRB3 with protective housing, normal sensitivity. Housing  $\varnothing$  17mm. Delivered without connecting cable. Terminal block easily accessible. Delivered complete with mounting flange and detector clamp.



4 286 1490 0

QRB3

### BOILERHOUSE MAINTENANCE

It is vitally important that personnel responsible for the day to day running of the equipment are briefed by the commissioning engineer, as on the initial setting up. Slight adjustments are made to suit your particular installation/oil pressure/nozzles etc., which should be noted.

1. Burner should be kept clean inside and out, it will be more reliable and if an oil leak occurs, it would be quickly spotted.
2. Inspect burner daily to see if there are any vibrations from correct operating sequence, as follows:—
  - 2.1 Is oil pressure correct on nozzle line gauge (should be 20.7 Bar/300 PSI NOL125/150 or 27.6 Bar/400 PSI NOR125/150). If on heavy fuel it has fallen back, clean pre-heater filter, which is situated in block on top of pre-heater. Remove by taking out four retaining bolts and disconnect oil line. Lift filter out and wash in kerosene. If oil pressure is still low check oil supply, stop/fire valves, ring main pumps/temperature etc., and also cold oil filter.
  - 2.2 If there is an inspection window in appliance through which flame can be observed, flame should be inspected and if any irregularities are seen, action should be taken, i.e. nozzles cleaned and any deposit removed from inside of flame tube and diffuser.
  - 2.3 To clean nozzles, switch off electric supply to burner and on heavy oil, disconnect quick release oil line coupling on burner cover and electrical supply to solenoids. Take out screws retaining top covers and remove HT leads, heavy oil assembly can be removed through casing complete with diffuser. With light oil (Models NOL) undo Allen screw from union block on right hand side of casing and then two nuts retaining nozzle assembly inside casing and assembly can be pulled out of casing. Note position of nozzles, they are most probably different sizes and it is important they go back in correct position. Nozzles should be stripped down and cleaned carefully, never use anything abrasive which will scratch finely finished surfaces of the nozzle. NOZZLE LIFE IS APPROXIMATELY 2000 HRS. OPERATION, after this period wear will affect atomisation and plant efficiency will drop.
  - 2.4 Check PE cell and clean if necessary.
  - 2.5 On NOR Burners rotate cleaning nob of cold oil filter (heavy oil) daily.

- 2.6 Check pre-heater oil temperature.
- 2.7 On NOR Burners the cold oil filter (heavy oil) should have plug removed from sump and sludge water drained off approximately every six weeks. Light oil filter on NOL Burners should have bowl dropped and filter washed in kerosene every six months.
- 2.8 It is usual practice to shut boiler(s) off whilst delivery of oil is being made and allow approximately 30 mins. for sediment to settle, before starting burners.
- 2.9 Make sure burner can always obtain sufficient air for combustion, never block any ventilation areas.
- 2.10 Keep boiler surface clean, as any accumulation of soot will insulate and increase gas exit temperature. Always cover up burner during cleaning operation.

### 3. FAULT FINDING

- 3.1 If burner fails to start, make sure all thermostats and switches in control circuit have contacts in 'made' position and on NOR Burners the oil pre-heater 'Excess Limit' thermostat has not turned, this is resettable.
- 3.2 Check that electricians to the burner are 'live' and control or main circuit fuses have not blown.
- 3.3 If burner is found at lockout (Red Light showing).
- 3.4 Reset motor(s) overloads (fan or pump).
- 3.5 Press lockout reset button and observe starting cycle (allow time for control box to cycle or pre-heater to warm up).
- 3.6 If flame occurs, followed by immediate lockout — check PE cell — check air regulator sequence — observe if oil pressure reads correctly, if not check pre-heater filter (heavy oil) — see there is sufficient oil in storage tank — bleed oil pump in case it is partially air locked. Check to see if stop/fire valve in oil supply line is fully open — check oil temperature (heavy oil).
- 3.7 If burner starts with correct oil pressure and no flame appears, check ignition system/HT leads, connections and electrodes/setting/solenoid operation/nozzle cut-offs (heavy oil) and mag. valves (light oil).

Under no circumstances keep re-setting lockout button — should lockout still occur after two attempts — call in skilled service engineer.

Always quote burner model/serial/specification number when requesting service or spares.

These instructions are intended for general guidance of boilerhouse attendants.

### SATRONIC TMO 720-4 CONTROL BOX

#### Introduction

The TMO 720-4 oil burner safety control is designed for use with fully automatic oil burning equipment over 36 litres per hour.

It provides a safe light-up and shut-down sequence for the burner and incorporates pre-purge, pre-ignition, post ignition and lockout safety time intervals. In addition the control allows the option of interlocking with the burner air damper system, a 'direct lockout' or 're-cycle' operation on running flame failure, and a two stage firing sequence.

The control box operates in conjunction with the FZ 711 photo-resistor assembly which monitors the oil burner flame.

#### Features

1. The control box and photo-resistor have a working ambient temperature of up to 60°C.
2. The timing sequence is controlled by a synchronous motor driving a cam switch assembly. This provides a consistent performance despite voltage variations in the supply.
3. A coloured programme indicator is incorporated to show the position reached by the control at any stage in the sequence.
4. A remote reset from lockout facility is provided in addition to the reset button supplied on the control box.  
Similarly, provision is made for a remote lockout warning signal.
5. A keying arrangement between control chassis and wiring base prevents incorrect connection between the two parts.
6. The main relay and flame relay operate on d.c. to give better noiseless operation with voltage variations.
7. Extra terminals for neutral and earth wiring connections are provided in the base, 4 neutral terminals, 3 for earth.
8. Cut-away links on the underside of the control chassis allow the option of a choice of programmes. 'Re-cycle' or a 'direct lockout' feature on running flame failure can be chosen.  
Interlock with the burner air damper system is available if required.
9. Correct opening and closing of the air damper during the start-up cycle can be monitored. If these conditions are not met, lockout can occur following a delay of 60 seconds (see wiring link III).
10. The high flame stage,  $V_2$ , does not require separate auxiliary contacts on the air damper system.
11. A long or short pre-ignition period is provided.
12. The electrical and electronic components are incorporated onto two plug-in printed circuit boards.

### OPERATION

#### Normal Start-up

When the controlling thermostat calls for heat, the burner motor and ignition circuits are switched on, and following a short delay the air damper circuit is also energised.

If interlock with the air damper system is required, see Fig. 7, the damper will open to the 'high' air position.

The auxiliary switch indicating this position will eventually be made and the synchronous timer in the control starts to run.

After a period of approximately 30 seconds, the timer stops and the air damper system is de-energised.

When the damper has returned to the 'low' air position the auxiliary switch for this position will be made.

The timer then restarts and continues the sequence. Terminal 5 supplying the low flame oil valve is energised, releasing fuel to the combustion chamber.

When a flame is established, the FZ 711 photo-resistor on 'seeing' the flame, causes the flame relay inside the control to hold-in. This allows the timer to run on further, switching off the ignition circuit and eventually terminal 6 is energised which initiates the high flame operation.

Provided the high flame control thermostat is calling for heat, terminals 12 and subsequently 13, will be energised to operate the air damper to the 'high air' position.

When this position is proved by the damper auxiliary contact, terminal 21 is energised and oil valve  $V_2$  is switched on.

Shortly after this, the synchronous timer stops and the control is then in the 'run' position.

If interlock with the air damper system is not required, see Fig. 8, the sequence is broadly as described above. In this instance the synchronous timer will start immediately and carry on until the 'run' position is reached, with the high flame oil valve having been energised via terminal 6.

#### Failure to establish flame

If a flame is not established correctly, the control goes to lockout, shutting down the burner within 5 seconds from the initial release of fuel.

The lockout signal lamp behind the reset button is energised and the burner cannot be restarted until the reset button is pressed.

Reset can be effected immediately following a lockout, and upon resetting the timer runs to the 'start' position, and a full light sequence begins as previously described under 'normal start-up'.

#### Running Flame Failure

If, during a run the oil burner flame is extinguished, the photo-resistor reacts instantly to the loss of flame. The behaviour of the control will depend upon which cut-away link on the underside of the control chassis is broken.

a) Wiring link II removed for 're-cycle' operation.  
With this link removed, upon loss of flame the control will shut-down the burner immediately.

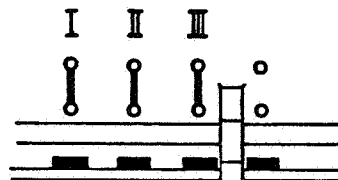
After a short delay a restart attempt will be automatically provided as described under 'normal start-up'.

b) Wiring link II not removed.  
With this link intact, upon loss of flame control will go to lockout immediately.

The burner can only be re-started by pressing the reset button.

### SELECTION OF PROGRAMME (see Fig. 6 below)

Fig. 6 Underside Wire Links



1. 'Re-cycle' or Direct Lockout.  
If a 're-cycle' feature is required after running flame failure, wiring link II on the underside of the control chassis must be broken.

For a 'direct lockout' feature this link must be left intact.

2. Air Damper Control  
If Interlock with the air damper is not required, wiring link I on the underside of the control chassis must be left intact. Also terminals 14—15 in the wiring base must be linked together.

For interlock with the damper 'open' position, wiring link I should be left intact, and the damper auxiliary switch must be wired across terminal 14 and 15 in the wiring base.

For interlock with the damper 'closed' position, break wiring link I, link terminals 14—15 in the wiring base, and damper auxiliary switch should be wired across terminals 15 and 16.

For interlock with both air damper 'open' and 'closed' positions, wire in accordance with Fig. 7, and break wiring link I.

3. Damper failure lockout  
If the air damper motor or actuator fails to operate correctly, the control box goes to lockout after 60 secs. Wiring link III controls this feature, and if this is not required, this link must be broken. Wiring link III must be broken if the damper running time exceeds 60 secs., or heavy oil pre-heating is used.

### COMMISSIONING AND ROUTINE CHECKS

Generally the control box should not require any maintenance and no attempt should be made to take off the cover or break the seals.

The photo-resistor viewing surface should be periodically checked for dirt, dust, etc., and wiped clean, otherwise its sensitivity will be reduced and lockout can occur.

On commissioning the installation and after each routine service visit it is advisable to carry out the following checks.

1. Cover up the photo-resistor completely and allow the burner to start.

At the end of the lockout safety time (yellow section) the burner should shut-down and the control go to lockout. The photo-cell must be completely covered during this test otherwise it may pick up stray light.

2. Expose the photo-resistor to a light source and attempt to start the burner.

The control should go to lockout almost immediately.

3. Allow a normal start-up and with the burner in the 'run' condition cover up completely the photo-resistor.

The burner will either:

- a) Shut-down immediately and the control will go to lockout, or
- b) Shut-down immediately and after a short delay, attempt a full re-start sequence, eventually shutting down again with the control going to lockout.

a) or b) will depend upon which programme sequence has been chosen.

#### **FAULT FINDING**

1. Burner will not start.  
Programme indicator remains on the end of the GREEN section, lockout signal not on.
  - a) Check wiring.
  - b) Check for live supply onto terminal 20.
  - c) Check for live supply onto terminal 9 to determine control circuit is complete.
  - d) Check neutral connections.
2. Lockout, with programme indicator at start or end of BLUE section.
  - a) No damper 'open' signal.
  - b) No damper 'closed' signal.
  - c) For applications where damper supervision is not required, check that wiring link I is intact, and that terminals 14—15 in the wiring base are linked together.

Special Note: The signals indicating damper 'open' and 'closed' must be detected within approximately 60 secs.

After expiry of this time, a lockout will result. This prevents the burner giving a continuous pre-purge.

3. Control goes to lockout, without burner start-up. Programme indicator in the BLUE section.
  - a) Check for stray light sources onto the FZ photo-resistor.
  - b) Check if photo-resistor has gone low resistance.
  - c) Check that oil valves are not letting oil by during pre-purge.
  - d) Control box has flame detection amplifier fault.
4. Burner Starts, no flame and control goes to lockout. Programme indicator at the end of the YELLOW section.
  - a) Check if ignition is present, and is in correct position.
  - b) Check that oil supply is O.K. and that the low flame oil valve is opening correctly when terminal 5 is energised.
5. Burner starts, flame established, control goes to lockout. Programme indicator at the end of the YELLOW section.
  - a) Check that the photo-resistor viewing surface is clean.
  - b) Check that photo-resistor is correctly positioned to see the flame.
  - c) Faulty control box or faulty photo-cell.
  - d) No supply onto terminal 20.

#### **SPECIAL NOTE**

If the control box goes to lockout it is generally performing the function it is designed for.

Causes of lockout can be:—

- (1) No ignition.
- (2) Ignition not in correct position, check electrodes, settings and ceramic insulators for cracks or damage.
- (3) No oil due to empty fuel tank.
- (4) No oil due to blockage in oil feed line to burner. Check filter and all hand valves are open.
- (5) No oil due to faulty burner motor, pump, oil solenoid valve or blocked nozzle.
- (6) Poor combustion.
- (7) Photo-resistor not positioned correctly or subject to stray light.
- (8) Faulty photo-resistor.
- (9) Faulty control box.

#### **SAFEGUARD AGAINST PHOTO-RESISTOR FAULTS OR FALSE LIGHT CONDITIONS**

The flame detection circuit is active continuously throughout operation and the control box gives a safeguard against these two conditions.

During the pre-purge and burner 'off' periods, the sensitivity of the flame detection circuit is raised. The sensitivity of the circuit automatically reverts to normal at the point where a correct flame signal would be received.

If at start-up or during the pre-purge period the photo-resistor acts wrongly as if flame is present, or false light is received on it, the control will go to lockout.

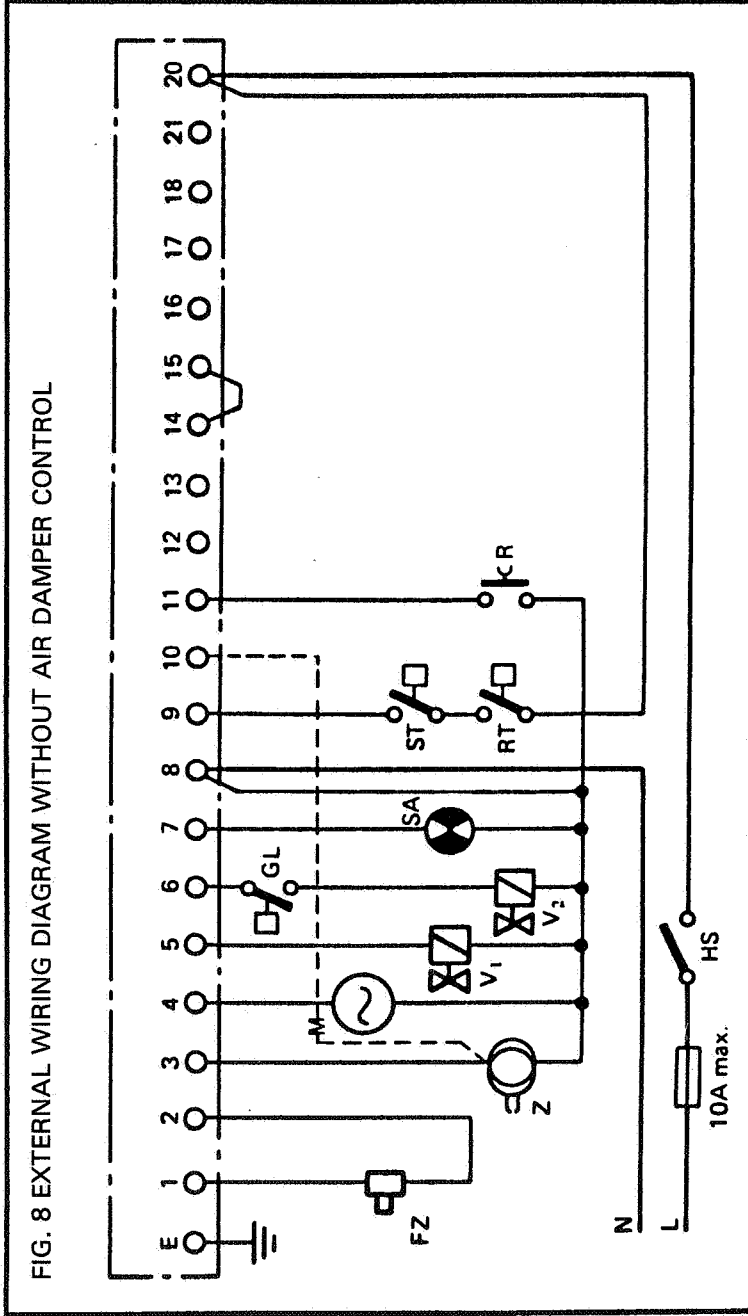
#### **SUMMARY OF SAFETY FEATURES**

1. Flame failure during a run results in burner shut-down with lockout or one re-start attempt.
2. Failure to establish flame on start-up, results in burner shut-down and lockout within 5 seconds from initial release of fuel.
3. Initial release of fuel is dependent upon the synchronous timer being operational and progressing towards the lockout position if required.
4. Where interlocked with the burner air damper system, failure to operate the air damper correctly prevents burner operation.  
This can result in lockout after 60 seconds to prevent damage to the ignition transformer (Wiring link III).
5. Restoration of the electric supply after power failure results in a full light-up sequence to safely re-start the burner.  
Power failure after lockout, will not interfere with this condition when the supply has been restored.
6. False flame signals result in burner shut-down followed by lockout.
7. This higher flame detection sensitivity during the 'off' and pre-purge periods, ensures that stray light or photo-cell defects are detected at an early stage so that hazardous conditions arising for the installation are prevented.

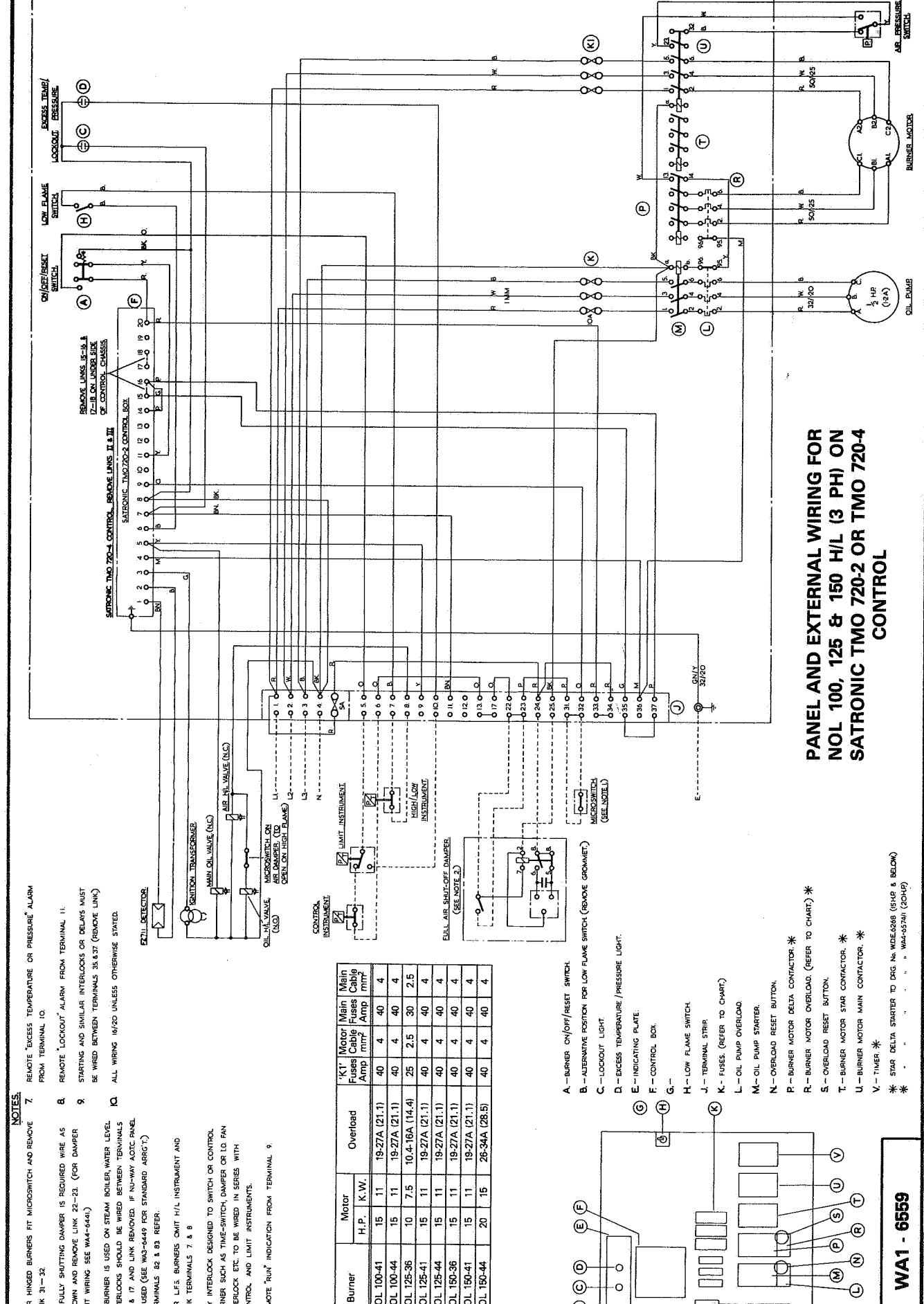




FIG. 8 EXTERNAL WIRING DIAGRAM WITHOUT AIR DAMPER CONTROL



- |    |   |                                           |                |   |                                          |
|----|---|-------------------------------------------|----------------|---|------------------------------------------|
| HS | — | Mians isolator switch                     | M              | — | Burner Motor                             |
| ST | — | Limit thermostat                          | Z              | — | Ignition Transformer                     |
| RT | — | Control thermostat                        | R              | — | Remote lockout reset switch, if required |
| GL | — | High flame control thermostat             | V <sub>1</sub> | — | Low flame oil valve                      |
| SA | — | External lockout signal lamp, if required | V <sub>2</sub> | — | High flame oil valve                     |
| LM | — | Air damper motor or actuator              | FZ             | — | Photo-resistor                           |



- NOTES:**
- FOR HINGED BURNERS FIT MICROSWITCH AND REMOVE LINK 31-32.
  - IF FULLY SHUTTING DAMPER IS REQUIRED WIRE AS SHOWN AND REMOVE LINK 22-23. (FOR DAMPER UNIT WIRING SEE WA4-6441).
  - IF BURNER IS USED ON STEAM BOILER WATER LEVEL INTERLOCKS SHOULD BE WIRED BETWEEN TERMINALS 13, 17 AND LINK REMOVED. IF NIP-WAY LOGIC PANEL IS USED (SEE WA3-449 FOR STANDARD ARR'G'T) TERMINALS 52 & 93 REFER.
  - FOR L.F.S. BURNERS OMIT H/L INSTRUMENT AND LINK TERMINALS 7 & 8.
  - ANY INTERLOCK DESIGNED TO SWITCH OR CONTROL BURNER SUCH AS TIME-SWITCH, DAMPER OR LD FAN INTERLOCK ETC. TO BE WIRED IN SERIES WITH CONTROL AND LIMIT INSTRUMENTS.
  - REMOTE "Run" INDICATION FROM TERMINAL 9.

Burner	Motor		Overload	'K1' Motor Fuses Cable Amp	Main Fuse Amp	Mfr. Infr.
	H.P.	K.W.				
NOL 100-41	15	11	19-27A (21.1)	40	4	4
NOL 100-44	15	11	19-27A (21.1)	40	4	4
NOL 125-36	10	7.5	10.4-16A (14.4)	25	2.5	30, 2.5
NOL 125-41	15	11	19-27A (21.1)	40	4	4
NOL 125-44	15	11	19-27A (21.1)	40	4	4
NOL 150-36	15	11	19-27A (21.1)	40	4	4
NOL 150-41	15	11	19-27A (21.1)	40	4	4
NOL 150-44	20	15	26-34A (28.5)	40	4	4

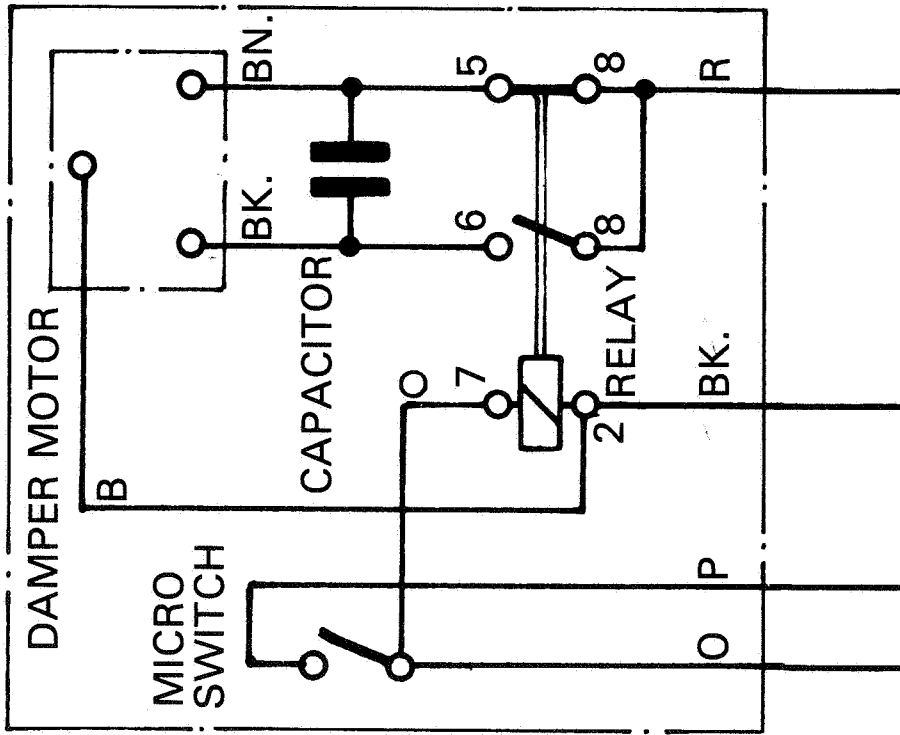
- A - BURNER ON/OFF/RESET SWITCH.
- B - ALTERNATE POSITION FOR LOW FLAME SWITCH (REMOVE GROUNDWIT).
- C - LOCKOUT LIGHT.
- D - EXCESS TEMPERATURE /PRESSURE LIGHT.
- E - INDICATING PLATE.
- F - CONTROL BOX.
- G -
- H - LOW FLAME SWITCH.
- J - TERMINAL STRIP.
- K - FUSES. (REFER TO CHART).
- L - OIL PUMP OVERLOAD.
- M - OIL PUMP STARTER.
- N - OVERLOAD RESET BUTTON.
- P - BURNER MOTOR DELTA CONTACTOR. \*
- R - BURNER MOTOR OVERLOAD. (REFER TO CHART). \*
- S - OVERLOAD RESET BUTTON.
- T - BURNER MOTOR STAR CONTACTOR. \*
- U - BURNER MOTOR MAIN CONTACTOR. \*
- V - TIMER. \*

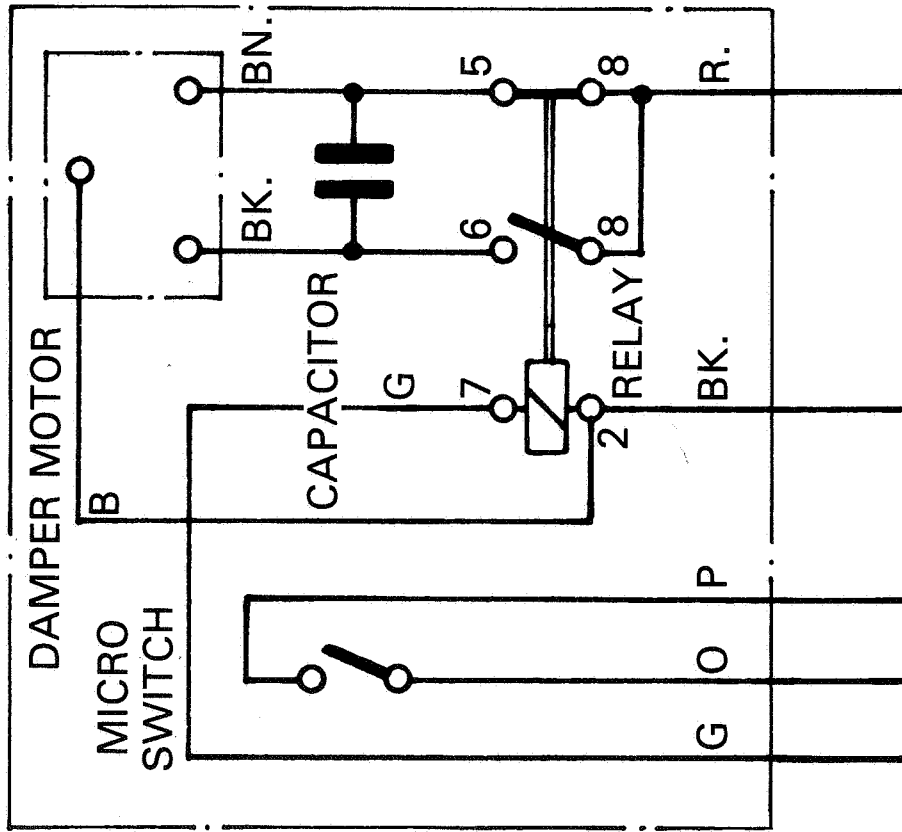
**PANEL AND EXTERNAL WIRING FOR  
NOL 100, 125 & 150 H/L (3 PH) ON  
SATRONIC TMO 720-2 OR TMO 720-4  
CONTROL**

**WA1 - 6559**

\* STAR DELTA STARTER TO DRG. NO. WDE-6268 (5HP & BELOW)  
\* WA4-6379 (20HP)

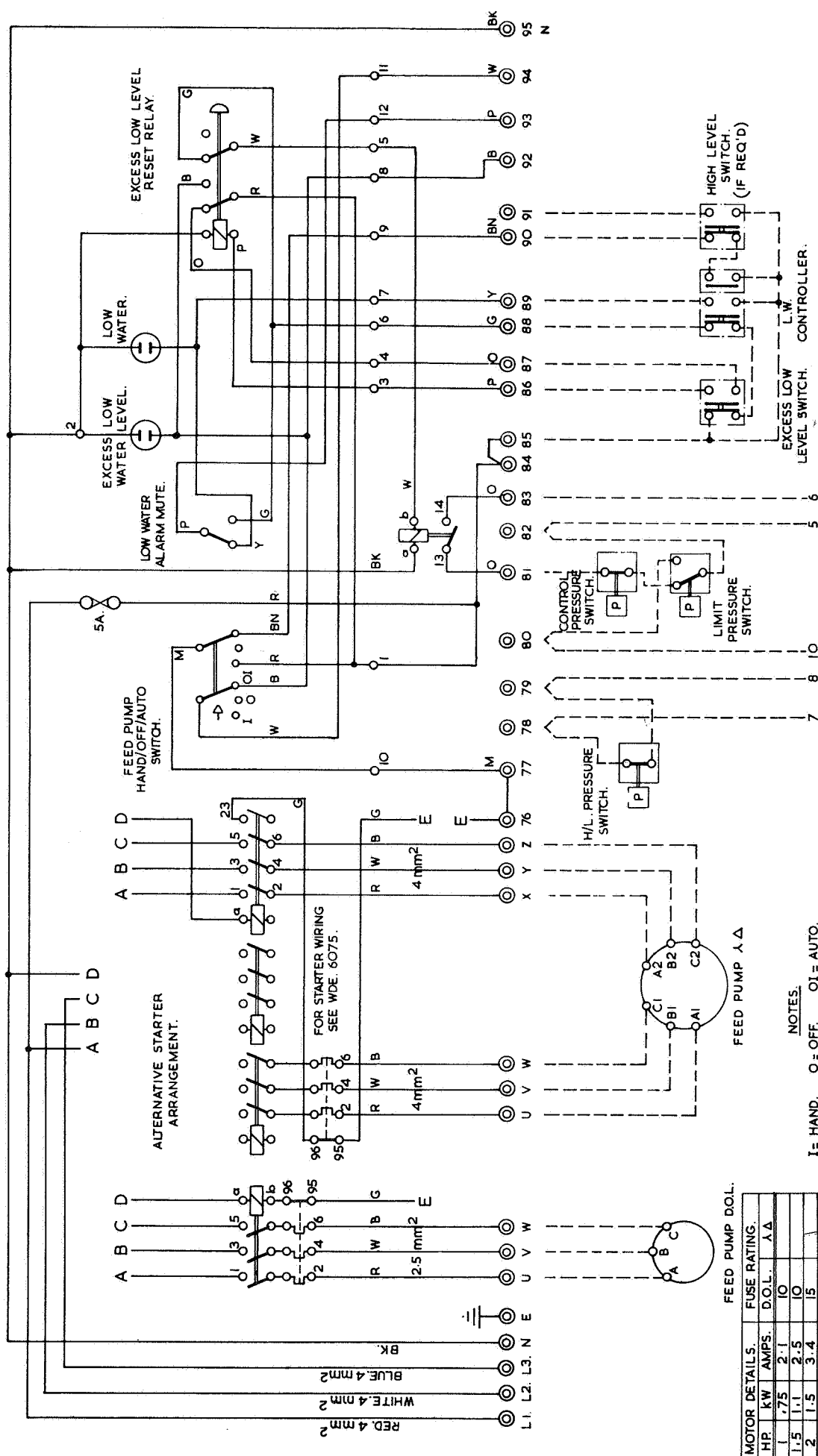






WA - 6441

H/L AIR DAMPER



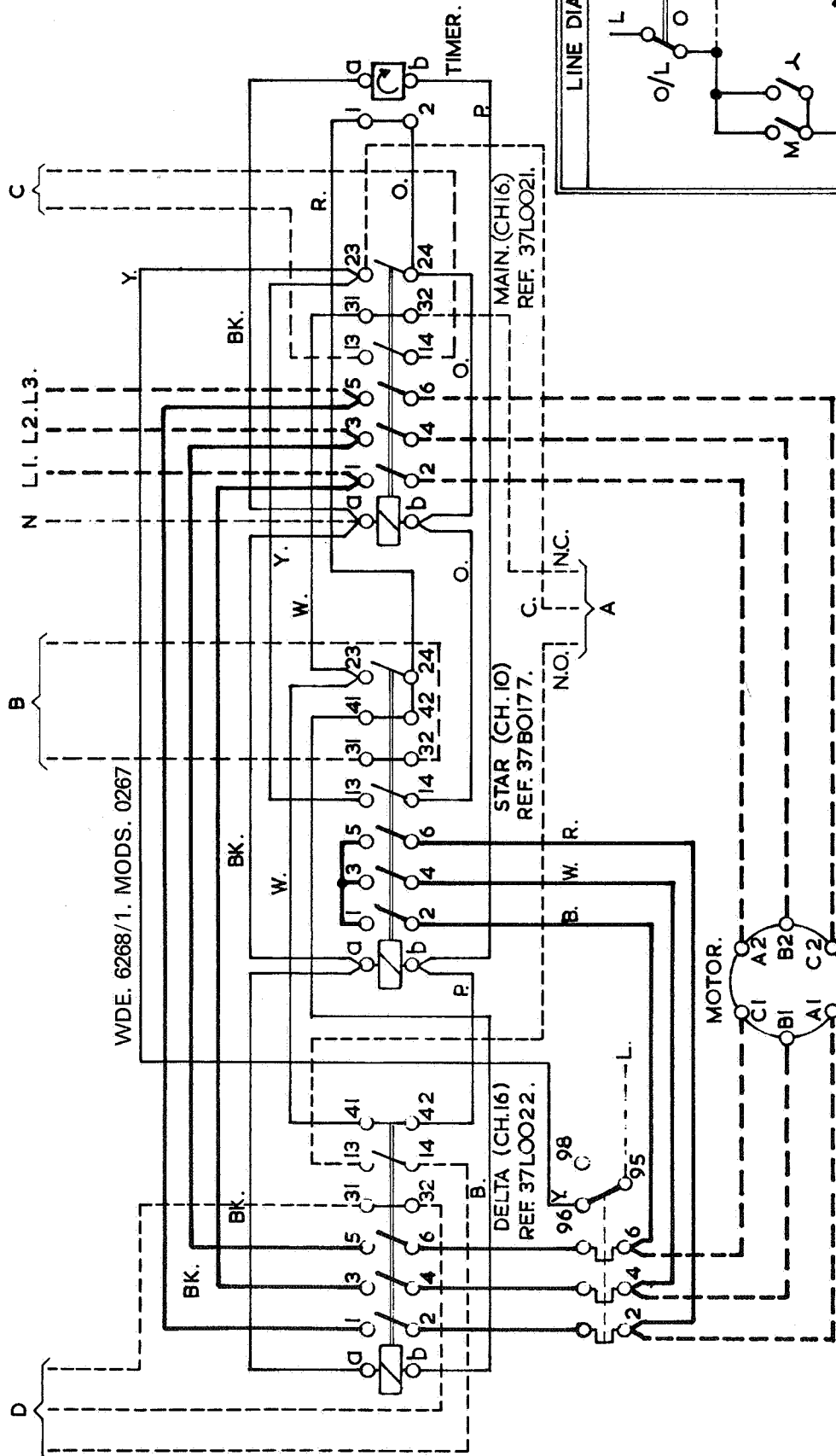
**AOTC - PANEL MK. II**

SEE BURNER WIRING DIAGRAM  
 IF PRESSURE SWITCHES ARE WIRED DIRECT TO THE BURNER TERMINAL STRIP, TERMINALS 81 & 82 MUST BE LINKED. 82 & 83 WILL THEN BE THE WATER LEVEL INTERLOCK AND MUST BE WIRED TO THE BURNER.

**NOTES.**  
 I = HAND. O = OFF. OI = AUTO.  
 REMOTE LOW WATER LIGHT :- TERMINAL 89.  
 REMOTE EXCESS LOW LEVEL :- " 92.  
 EXCESS HIGH LEVEL :- " 91.  
 LOW WATER ALARM :- " 93.  
 EXCESS LOW LEVEL ALARM :- " 94.

**FEED PUMP D.O.L.**

MOTOR HP.	KW	AMPS.	D.O.L.	A.A.
1	0.75	2.1	10	15
1.5	1.1	2.5	10	15
2	1.5	3.4	15	20
3	2.2	4.6	15	20
4	3	6.1	20	25
5	3.7	7.5	25	20
5.5	4	8.0	25	20
7.5	5.5	11.5	20	25
10	7.5	14.4	25	30
15	11	21.6	30	30

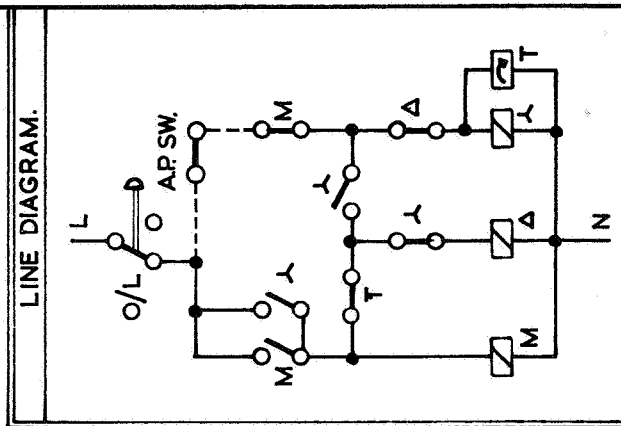


WDE. 6268/1. MODS. 0267

STAR (CH.10)  
REF. 37BO177.

DELTA (CH.16)  
REF. 37LOO22.

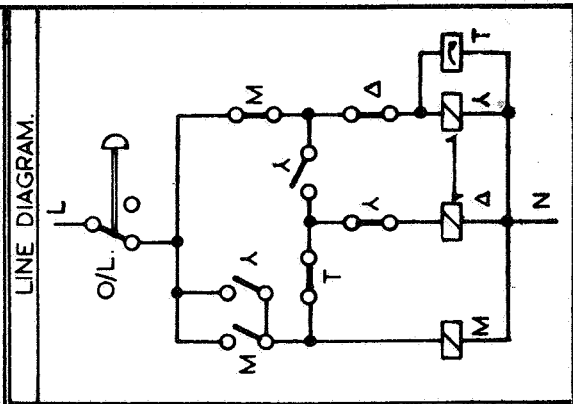
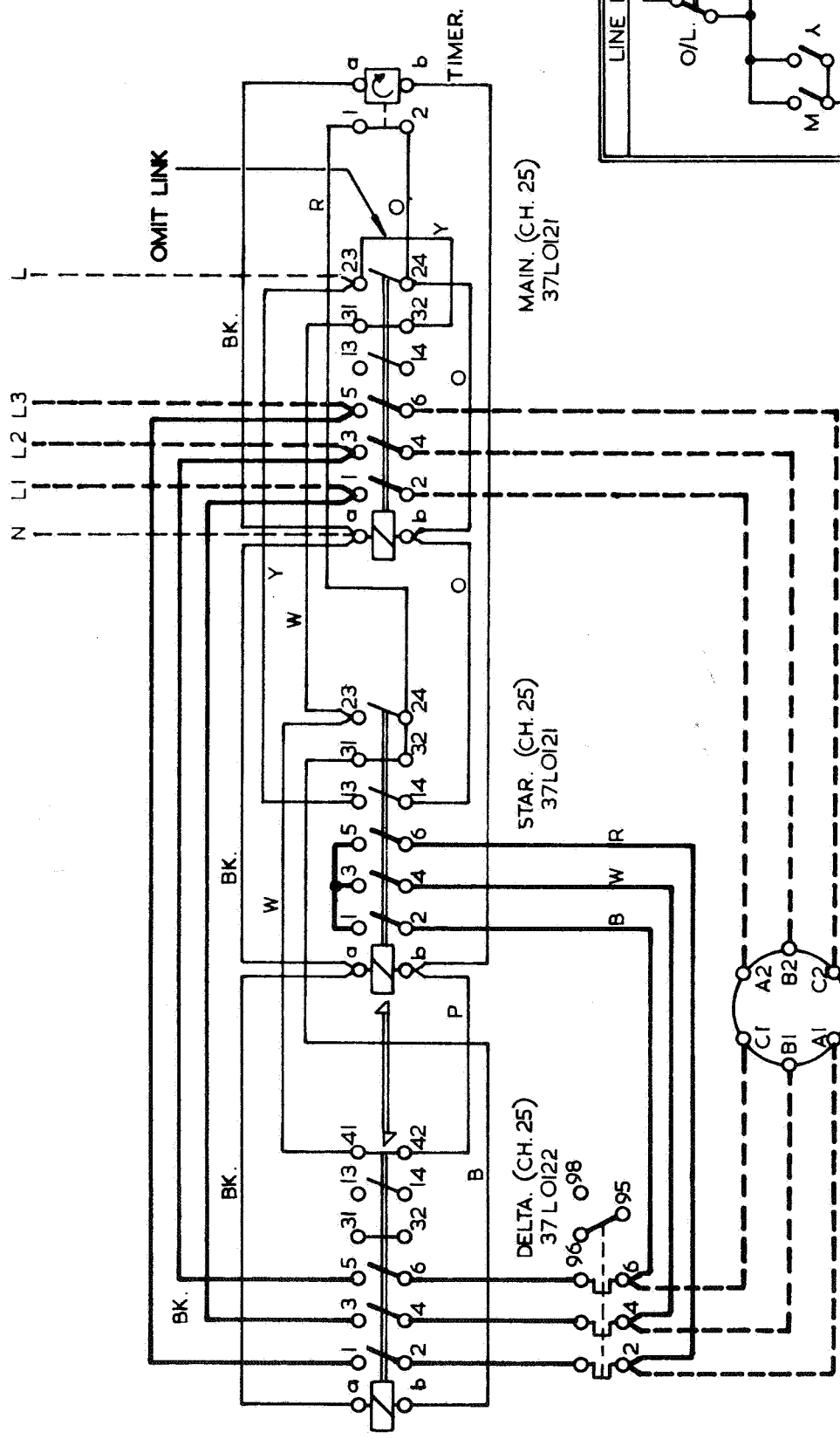
MAIN. (CH.16)  
REF. 37LOO21.



- A. AIR PRESSURE SWITCH.
- B. OIL PREHEATER INTERLOCK (IF REQ'D).
- C. OIL PRESSURE SWITCH INTERLOCK (IF REQ'D).
- D. OIL PUMP INTERLOCK.

**STAR-DELTA STARTER**





STAR-DELTA STARTER WITH MECHANICAL INTERLOCK

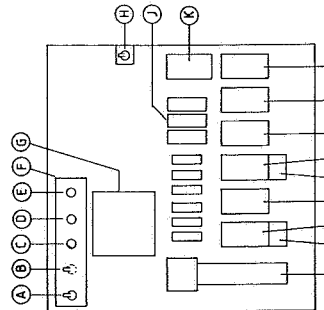
# PANEL AND EXTERNAL WIRING FOR NOR 100, 125 & 150 (3PH) ON LANDIS & GYR LAL.1 CONTROL WITH BERGER LAHR DAMPER UNIT

Burner	Motor		Overload	'F' Fuses	Motor Cable Rating	'F2' Rating	Heater Cable	Main Cable	Main Fuses
	K.W.	H.P.							
NOL 100-41	15	11	19-27A (21.1)	40	4	7.5	15	1.5	40
NOL 100-44	15	11	19-27A (21.1)	40	4	7.5	15	1.5	40
NOL 125-36	10	7.5	10.4-16A (14.4)	25	2.5	9	15	1.5	40
NOL 125-41	15	11	19-27A (21.1)	40	4	9	15	1.5	50
NOL 125-44	15	11	19-27A (21.1)	40	4	9	15	1.5	50
NOL 150-36	15	11	19-27A (21.1)	40	4	12	20	2.5	50
NOL 150-41	15	11	19-27A (21.1)	40	4	12	20	2.5	50
NOL 150-44	20	15	26-35A (28.5)	40	4	12	20	2.5	60

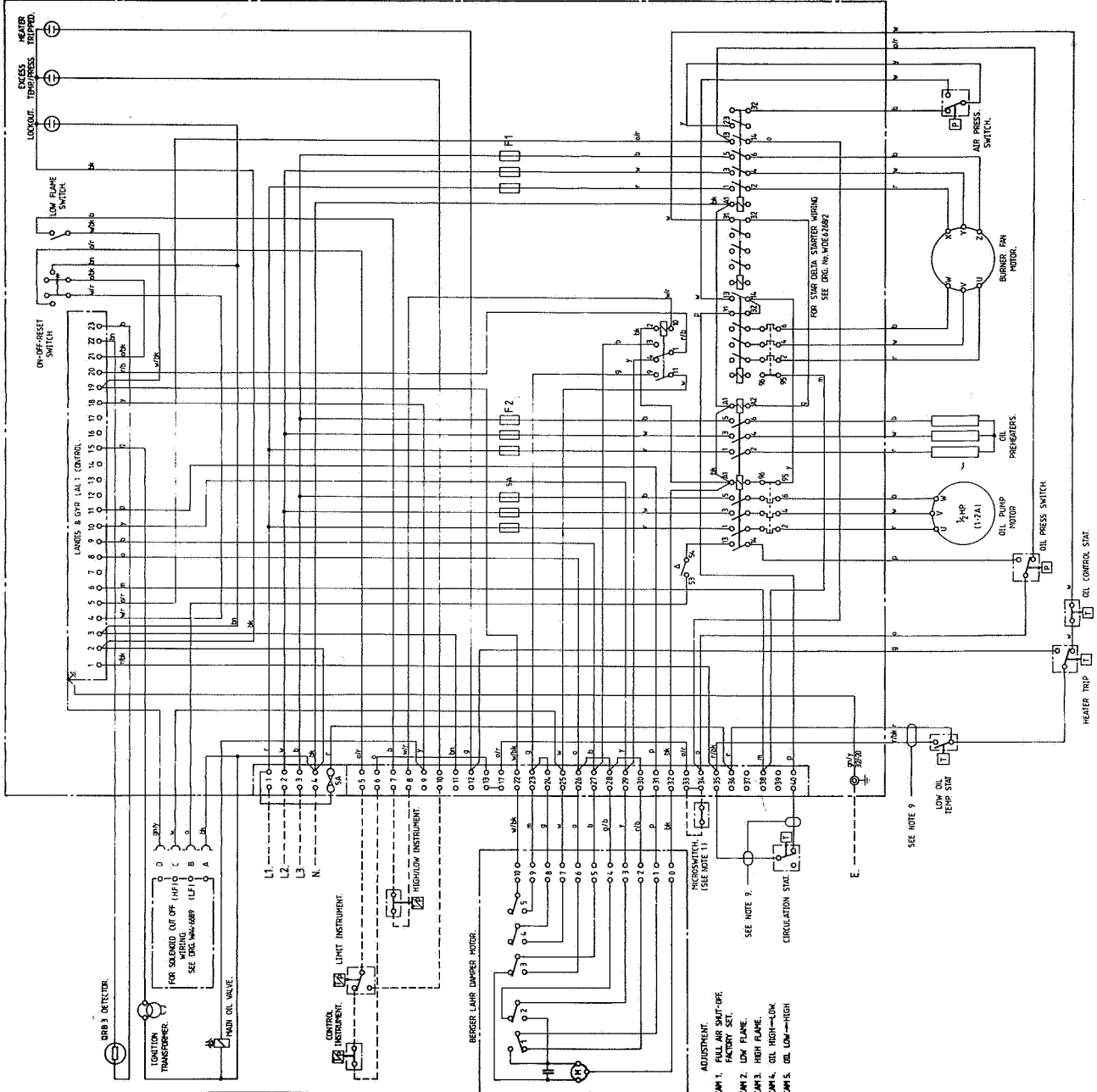
### NOTES:

- FOR HIBED BURNERS FIT MICROSWITCH AND REMOVE LINK 33-34.
- IF BURNER IS USED ON STEAM BOILER, WATER LEVEL INTERLOCKS SHOULD BE WIRED BETWEEN TERMINALS 13 & 17 AND REMOVE LINK. IF NO-WAY A.O.I.C. PANEL IS USED (SEE WA-7025 FOR STANDARD ABBOT). FOR 20HP/15KW/1 MOTOR USE STARTER TO DRG. NO. WA-4574/2.
- FOR LOW-HIGH-OFF BURNERS OMIT 'H' INSTRUMENT AND LINK TERMINALS 7 & 8.
- ANY INTERLOCK DESIGNED TO SWITCH OR CONTROL BURNER, SUCH AS TIME-SWITCH, DAMPER OR LG FAN INTERLOCK ETC. TO BE WIRED IN SERIES WITH CONTROL AND LIMIT INSTRUMENT.
- REMOVE 'RUN' INDICATION FROM TERMINAL 9.
- REMOVE 'EXCESS TEMPERATURE OR PRESSURE ALARM' FROM TERMINAL 10.
- REMOVE 'LOCKOUT ALARM' FROM TERMINAL 11.
- REMOVE 'HEATER TRIPPED' INDICATION FROM TERMINAL 12.
- TO CONVERT BURNER FOR USE WITH DISTILLATE FUEL, REMOVE AND ISOLATE RED AND RED-BLACK WIRES FROM TERMINALS 35 & 36 ALSO RED-BLACK AND PINK WIRES FROM TERMINALS 35 & 40 AND LINK TERMINALS 35 & 36.
- FOR 20HP/15KW/1 MOTOR USE STARTER TO DRG. NO. WA-4574/2.
- ALL WIRING 16/20 UNLESS OTHERWISE STATED.

- A — ON-OFF-RESET SWITCH.  
 B — ALTERNATIVE POSITION FOR LOW FLAME SWITCH.  
 C — LOCKOUT LIGHT.  
 D — EXCESS TEMPERATURE/PRESSURE LIGHT.  
 E — HEATER TRIPPED LIGHT.  
 F — INDICATING PLATE.  
 G — CONTROL BOX.  
 H — LOW FLAME SWITCH.  
 J — FUSES (REFER TO CHART).  
 K — RELAY.  
 L — TERMINAL STRIP.  
 M — OIL PUMP MOTOR OVERLOAD.  
 N — OIL PUMP MOTOR STARTER.  
 P — HEATER CONTACTOR.  
 R — BURNER FAN MOTOR OVERLOAD (REFER TO CHART). \*  
 S — BURNER FAN MOTOR DELTA CONTACTOR. \*  
 T — BURNER FAN MOTOR STAR CONTACTOR. \*  
 U — BURNER FAN MOTOR MAIN CONTACTOR. \*  
 V — THERM. \*  
 \* — STAR DELTA STARTER TO DRG. NO. W6E628B/2.



WA1 - 7332



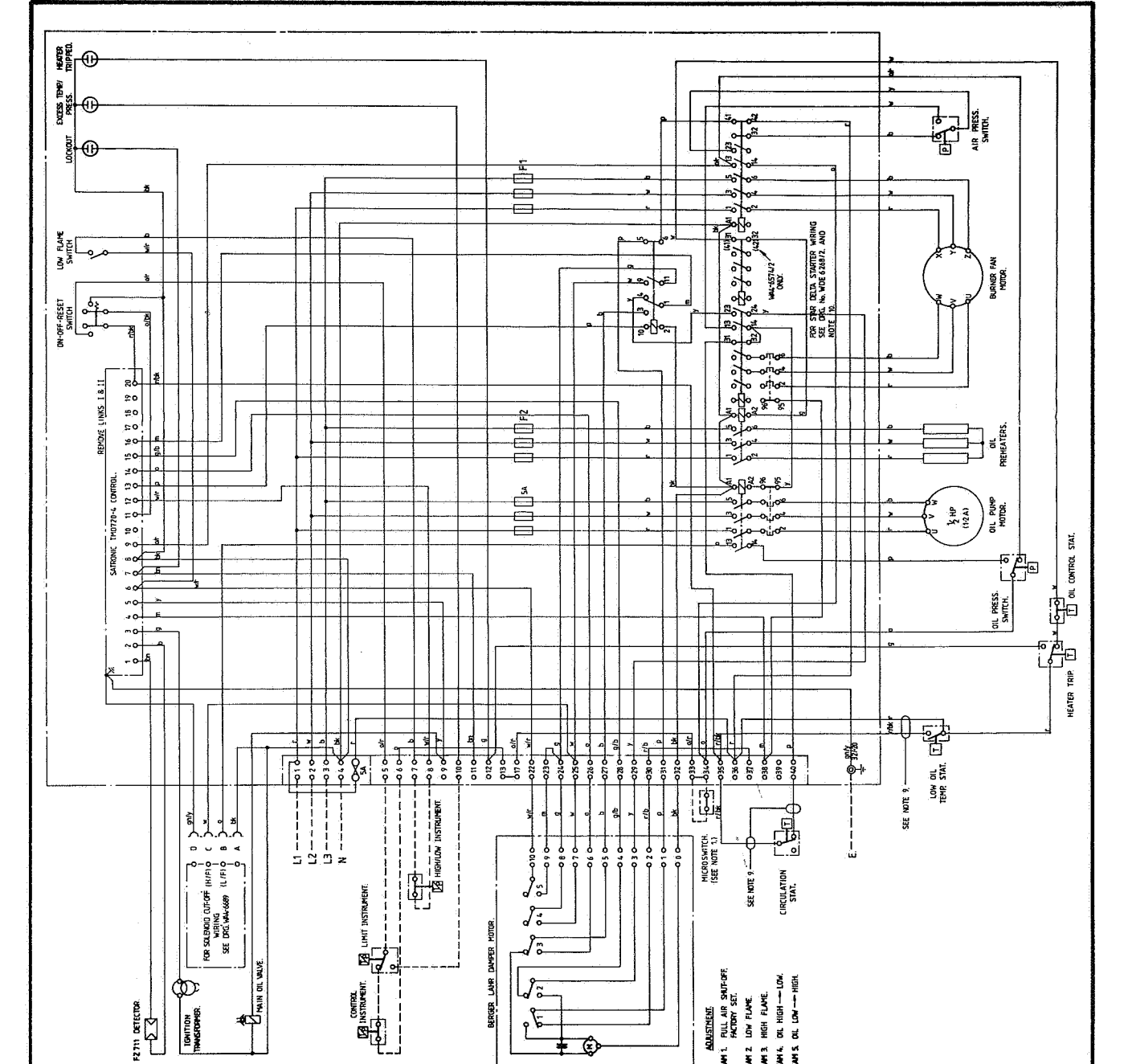
# PANEL AND EXTERNAL WIRING FOR NOR 100, 125 & 150 H/L (3PH) ON SATRONIC TMO 720-4 CONTROL WITH BERGER LAHR DAMPER UNIT

Burner	Motor		Overload	'F2' Heater Rating (K.W.)	'F2' Heater (K.W.)	Main Heater (K.W.)	Main Fuses (A)	Main Cable (A)		
	K.W.	H.P.								
NOL 100-41	15	11	19-27A (21.1)	40	4	7.5	15	1.5	40	10
NOL 100-44	15	11	19-27A (21.1)	40	4	7.5	15	1.5	40	10
NOL 125-36	10	7.5	10.4-16A (14.4)	25	2.5	9	15	1.5	40	6
NOL 125-41	15	11	19-27A (21.1)	40	4	9	15	1.5	50	10
NOL 125-44	15	11	19-27A (21.1)	40	4	9	15	1.5	50	10
NOL 150-36	15	11	19-27A (21.1)	40	4	12	20	2.5	50	10
NOL 150-41	15	11	19-27A (21.1)	40	4	12	20	2.5	50	10
NOL 150-44	20	15	26-36A (28.6)	40	4	12	20	2.5	60	10

- NOTES.**
- FOR WINDED BURNERS FIT MICROSWITCH AND REMOVE LINK 33-34.
  - IF BURNER IS USED ON STEAM BOILER, WATER LEVEL INTERLOCKS SHOULD BE WIRED BETWEEN TERMINALS 13 & 17 AND REMOVE LINK. IF IN-WAY A.O.I.C. PANEL IS USED (SEE WA3-7025 FOR STANDARD ARR.) TERMINALS 82 & 83 REFER.
  - FOR LOW-HIGH-OFF BURNERS OMIT H.C. INSTRUMENT AND LINK TERMINALS 7 & 8.
  - ANY INTERLOCK DESIGNED TO SWITCH ON CONTROL BURNER SUCH AS TIME SWITCH, DAMPER OR I.D. FAN INTERLOCK ETC. TO BE WIRED IN SERIES WITH CONTROL AND LIMIT INSTRUMENT.
  - REMOTE 'RUN' INDICATION FROM TERMINAL 9.
  - REMOTE 'EXCESS TEMPERATURE OR PRESSURE' ALARM FROM TERMINAL 10.
  - REMOTE 'LOCKOUT' ALARM FROM TERMINAL 11.
  - REMOTE 'WATER TRIPPED' INDICATION FROM TERMINAL 12.

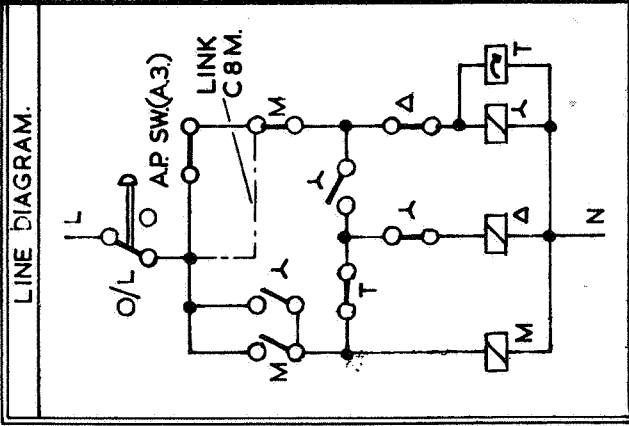
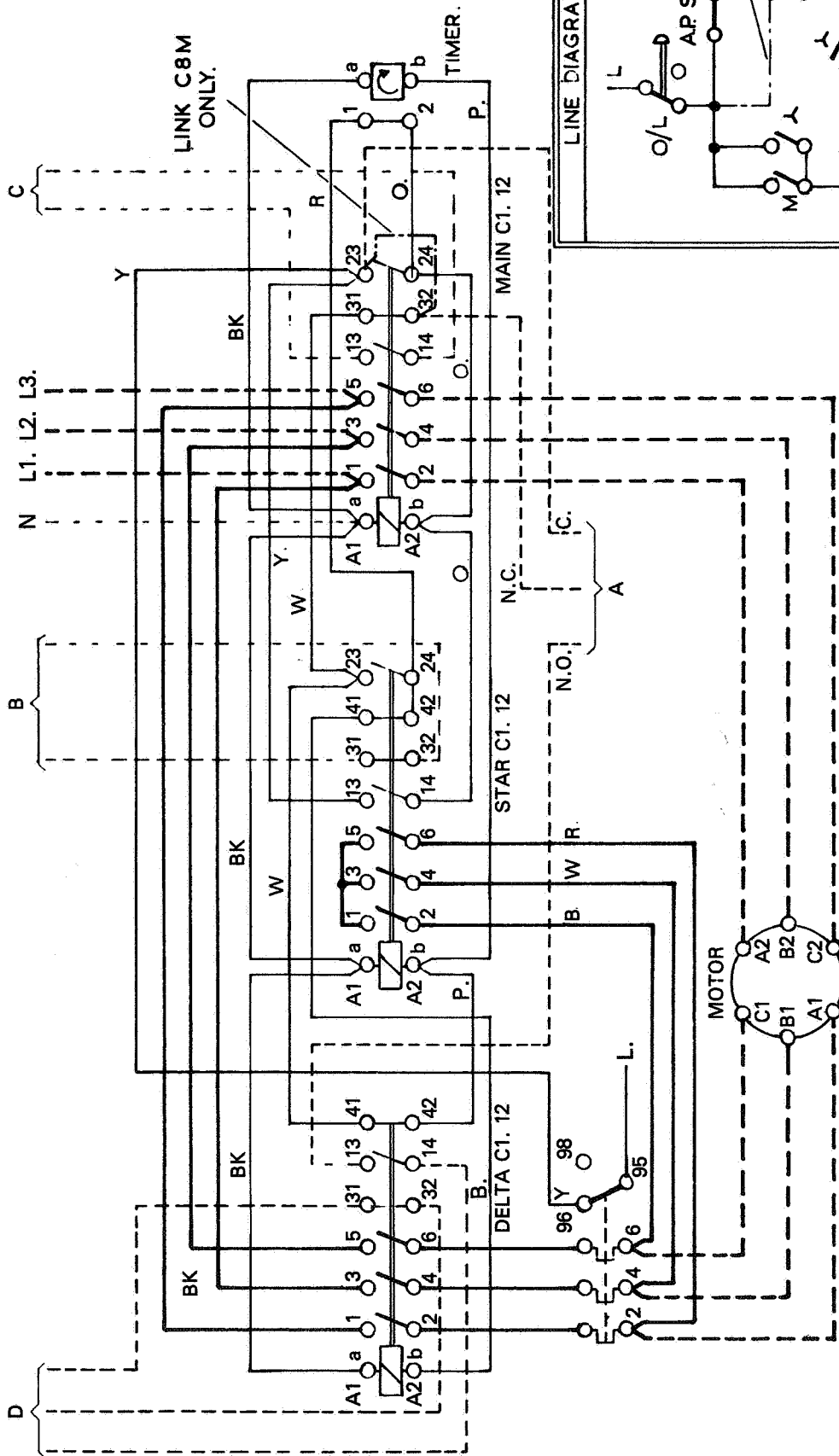
- TO CONVERT BURNER FOR USE WITH DISTILLATE FUEL, REMOVE AND ISOLATE RED AND RED/BLACK WIRES FROM TERMINALS 38 & 39. ALSO RED/BLACK AND PINK WIRES FROM TERMINALS 35 & 40 AND LINK TERMINALS 35 & 36.
- FOR 20HP (15KW) MOTOR USE STARTER TO ORIG. No. WA1-5574/2
- ALL WIRING 16/20 UNLESS OTHERWISE STATED.

- ADJUSTMENTS:**
- FULL AIR SHUT-OFF.
  - LOW FLAME.
  - HIGH FLAME.
  - OIL HIGH → LOW.
  - OIL LOW → HIGH.
- LEGEND:**
- A — ON-OFF-RESET SWITCH.
  - B — ALTERNATIVE POSITION FOR LOW FLAME SWITCH.
  - C — LOCKOUT LIGHT.
  - D — EXCESS TEMPERATURE/PRESSURE LIGHT.
  - E — HEATER TRIPPED LIGHT.
  - F — INDICATING PLATE.
  - G — CONTROL BOX.
  - H — LOW FLAME SWITCH.
  - J — FUSES. (REFER TO CHART)
  - K — RELAY.
  - L — TERMINAL STRIP.
  - M — OIL PUMP MOTOR OVERLOAD.
  - N — OIL PUMP MOTOR STARTER.
  - P — HEATER CONTACTOR.
  - R — BURNER FAN MOTOR OVERLOAD. (REFER TO CHART)\*
  - S — BURNER FAN MOTOR DELTA CONTACTOR.\*
  - T — BURNER FAN MOTOR SPAR CONTACTOR.\*
  - U — BURNER FAN MOTOR MAIN CONTACTOR.\*
  - V — THERM.\*
- \* — STAR DELTA STARTER TO ORIG. No. WA1-6247/2



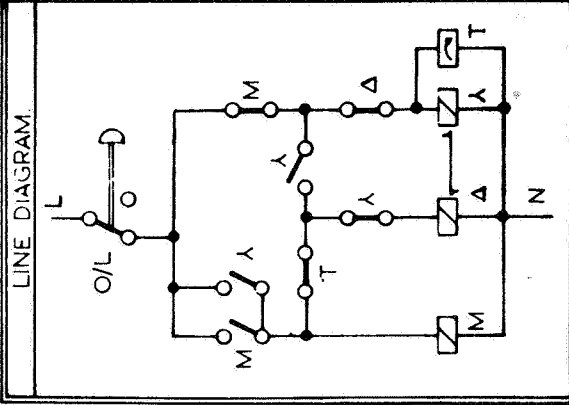
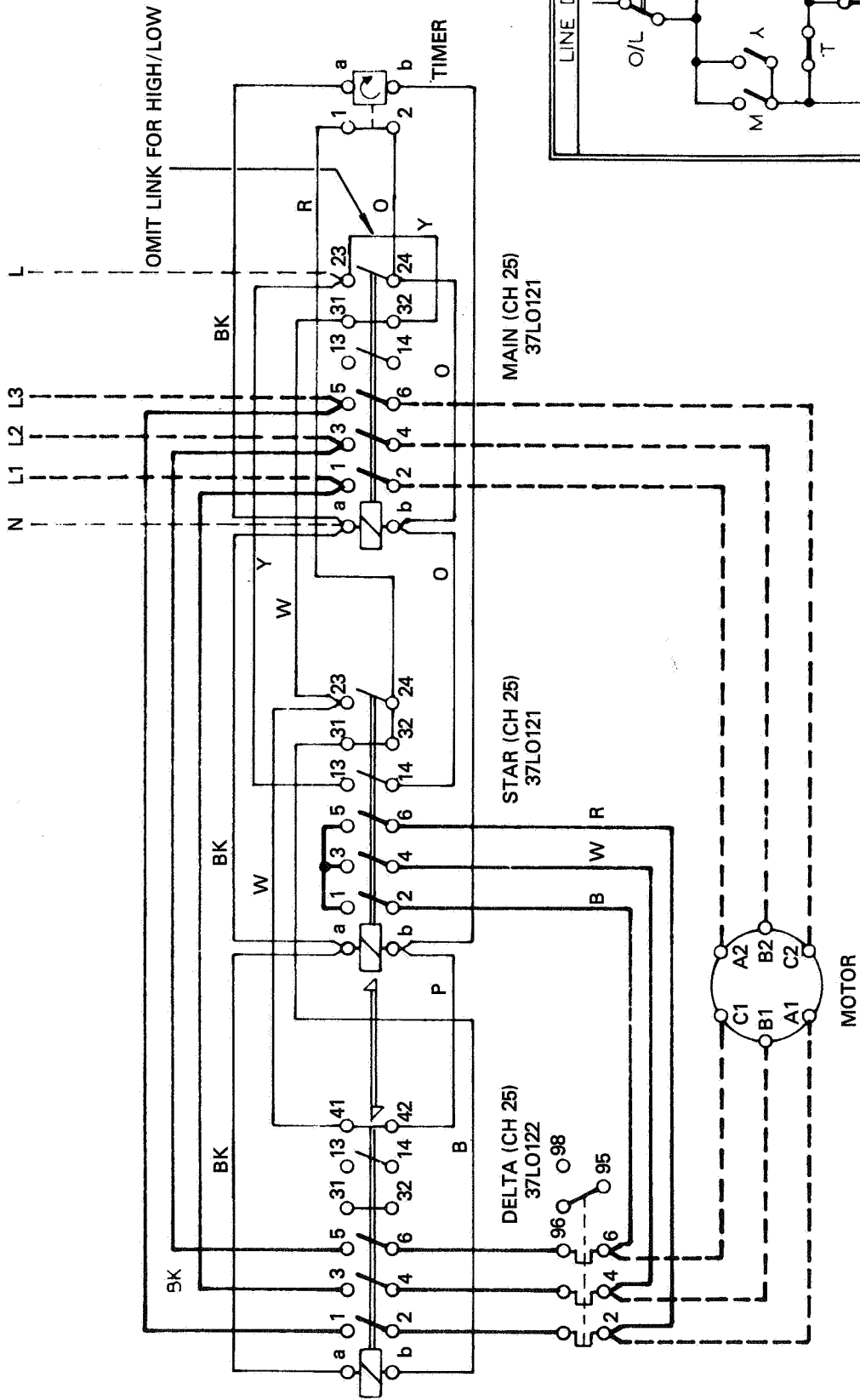
WA1 - 7311



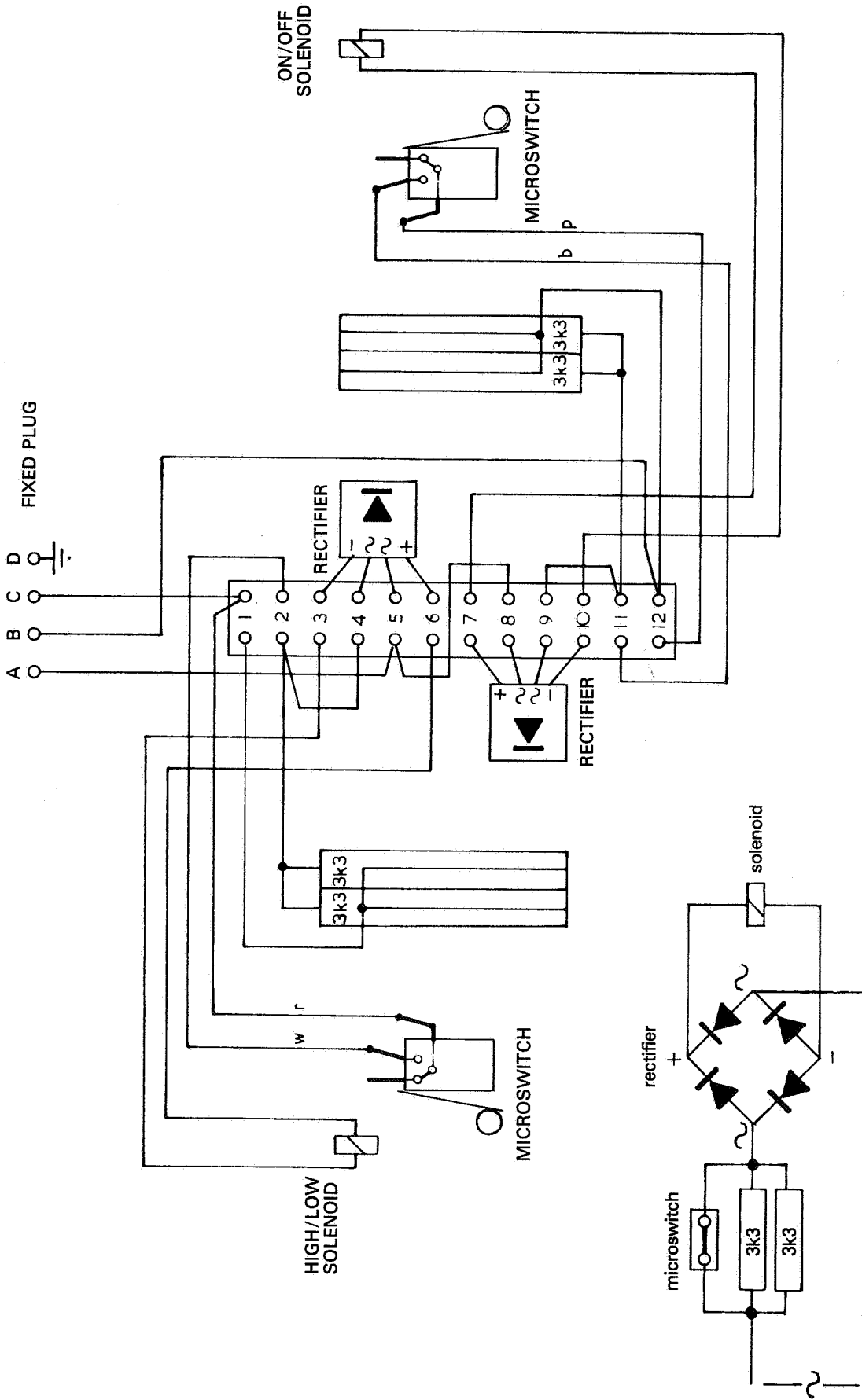


- A. AIR PRESSURE SWITCH
- B. OIL HEATER INTERLOCK (IF REQ'D)
- C. AIR PRESSURE SWITCH INTERLOCK (IF REQ'D)
- D. OIL PUMP INTERLOCK

**STAR-DELTA STARTER**



CH. 25 STAR-DELTA STARTER WITH MECHANICAL INTERLOCK



CONN'S FOR NOZZLE CUT-OFF SOLENOIDS WITH RECTIFIER AND ECONOMY RESISTORS

## BURNER SETTING RECORD

1. Burner Type .....
2. Burner Specification .....
3. Nozzle Type and Size Reference .....
4. Pump Pressure - Bar .....
5. Low Flame Spill Pressure - Bar .....
6. High Flame Spill Pressure - Bar .....
7. Turn-Down Ratio .....
8. Oil Throughput Kg/H .....
9. % CO<sub>2</sub> High Flame .....
10. % CO<sub>2</sub> Low Flame .....
11. Smoke Number H/F .....
12. Smoke Number L/F .....
13. °C Oil Temperature (Pre-Heater) .....
14. Date of Commissioning .....

**This form must be completed by the Commissioning Engineer**



# BOILERHOUSE INSTRUCTIONS

## NOL & NOR 100, 125 & 150

These instructions are provided for the benefit of the operator and are intended to be of assistance in making minor adjustments and providing the burner with proper maintenance, cleaning and lubrication. Additional information can be obtained through your installer or from the manufacturer.

### BOILERHOUSE VENTILATION

It is most important that the boilerhouse has an adequate supply of fresh air for both ventilation and combustion purposes.

### PUMP BLEEDING

If the fuel tank is allowed to drain completely it will be necessary to bleed the oil pump free of air by slackening the plug in the pressure gauge port allowing oil to run through until air free. (See pump instructions.)

### OIL FILTRATION - SEDIMENT REMOVAL

There is an oil strainer inside the body of the fuel pump and a separate oil filter between the oil pipe from the tank and the oil burner. The oil strainer should be removed and cleaned with paraffin during the pre-season check-up. At the same time the oil filter cartridge should be replaced or cleaned, as appropriate for the type fitted. Bleed fuel pump free of air, as described above, to remove any trapped air.

Draw off any accumulation of water or sediment in the fuel tank by opening the sludge cock in the tank bottom, immediately before any new delivery of fuel. Do not run the burner while the tank is being refilled and, if possible, do not restart for one hour after refilling is concluded.

### NOZZLE CLEANING

Nozzles cleaned as required see maintenance photographs. Replace after 2000 hours service.

### STARTING AND STOPPING

Start the burner by setting the thermostat pointer to a figure which is higher than the room or water temperature. Stop the burner by setting the thermostat to a point below this temperature.

The burner may set itself in the 'Safety Lockout' position — this will occur if the burner stops for any reason other than the action of the thermostat — and must then be restarted by pressing the reset button on the flameguard/sequence control. Ask your installer to instruct you in the proper method of resetting. If frequent resetting becomes necessary, call the service engineer whose name and address should be inserted below.

Do not attempt to start the burner when the fire-box may be full of oil vapour. It is desirable to allow the furnace to cool for about 15 minutes before resetting the control to restart the burner from the 'Lock-out' position.

### EMERGENCY STOP

The burner can be stopped in emergency by opening the wall switch provided on the line between the burner and the electric supply. The installer must identify this switch.

### CHECKING BURNER OPERATION

Inspect burner flame periodically. If it becomes lopsided or smokey, call a service engineer.

When cleaning the room housing the heater unit, always switch off the burner to reduce the amount of dust and lint drawn in through the air inlet.

### SUMMER CARE, AUTUMN RESTART

During the summer months, or whenever heat is not required over a considerable period, the wall switch may be opened. To restart the burner it is only necessary to close this switch.

At the close of the heating season have the furnace cleaned and flues swept. See that the complete burner plant, especially the electric ignition system, nozzle, oil filter etc., is checked over and cleaned by a competent service engineer.

### PREVENTIVE MAINTENANCE

Consult your heating engineer for advice on regular preventive maintenance intervals. It is not possible to recommend a service interval for universal use since operating conditions vary widely from installation to installation.

### CAUTION

Never burn rubbish or refuse in the heater fire-box. Never leave waste paper or rags lying around near the burner or the heater.

INSTALLER.....

NAME.....

ADDRESS .....

.....

FOR SERVICE TELEPHONE .....

NIGHTS, SUNDAYS OR HOLIDAYS .....

.....

TELEPHONE.....

Enertech Limited,  
P O Box 1,  
Vines Lane  
Droitwich,  
Worcestershire,  
WR9 8NA

**Tel:** +44 (0) 1905 794331  
**Email:** [info@nu-way.co.uk](mailto:info@nu-way.co.uk)

**Fax:** +44 (0) 1905 794017  
**Web:** [www.nu-way.co.uk](http://www.nu-way.co.uk)

